

TENDER SPECIFICATION

FOR HIGH TENSILE ROPE NET SYSTEM WITH STEEL WIRE KNOT

(ROCKFALL PROTECTION AND GEOHAZARD MITIGATION)

1.0 GENERAL

This specification covers the use of rhomboidal shape high tensile rope net system (with steel wire knot) for surface rock fall mitigation including the scope of furnishing and installation as per the special provisions mentioned in the specifications, instructions from the manufacturer/supplier of the rock fall mitigation system and as directed by the Engineer- In-Charge

2.0 MATERIALS

2.1 General Requirements

- a) The wire rope net system shall meet the minimum requirements of steel wire rope laid to form a panel, mainly mesh size, mesh opening type, knot and diameter of wrapping rope and edge rope, Zn coating and Knot tear resistance as specified in this document.
- b) Indigenously manufactured wire rope net system should be preferred, considering advantages of shorter delivery periods, no inventory pile-up and rates being not affected by fluctuation of exchange rate of foreign currency.
- c) A plant visits by the Engineer's representative to verify the manufacturer's quality control procedures and witness testing of products is also required prior to the dispatch of material

2.2 Transportation, Storage and Handling

The wire rope net system shall be delivered at site in the form of rolls/bundles. All rolls/bundles shall have a label or tag specifying name of the product, name of the manufacturer, quantity, date of manufacture and dimension.

Material shall be protected from mud, dirt, debris, any other harmful substances or mechanical damage during transportation.

Rolls/bundles shall be stored in a secured area sufficiently elevated above the ground and adequately covered to protect them from the following: site construction damage, precipitation, prolonged exposure to chemicals that are strong acids or have strong bases, flames including welding sparks, high temperatures, and any other environmental conditions that may damage the physical property values of the wire rope net system.

Any material, which is damaged during transportation, handling or storage and do not meet the minimum requirements of the specifications is liable for rejection by the Engineer.

Rockfall Protection System with Tensile Strength: 275 kN

The following performance specification describes a rolled cable net/high tensile rope net system, consisting of a mesh cover, rock or soil nailing, and connecting resp. boundary elements. The high tensile rope net system shall be tested by independent institutes such as IIT, THDC in a testing facility as per ETA (European Technical Approval) Standard. Only ETA certified wire meshes will be accepted.

Minimum Specifications of the High Tensile Rope Net System

Mesh Shape:	rhomboidal/rectangular
Max opening of mesh (mm):	300 x 300 mm
Min wire rope dia. (mm) as per IS 2266:	10
Min tensile strength of rope (N/mm ²) as per IS 2266/ISO2408:	1770
Breaking strength of rope (kN) as per IS2266:	71
Construction of Rope as per IS 2266:	6 x7 WSC
Min tensile Strength of mesh (kN/m):	275
Punching Resistance (kN):	400
Coating as per EN 10244-2:	Standard Zn Class A/Class B
Min tearing resistance of knot (kN):	28
Corrosion Protection of Knotting Wire:	95%Zn/5%Al

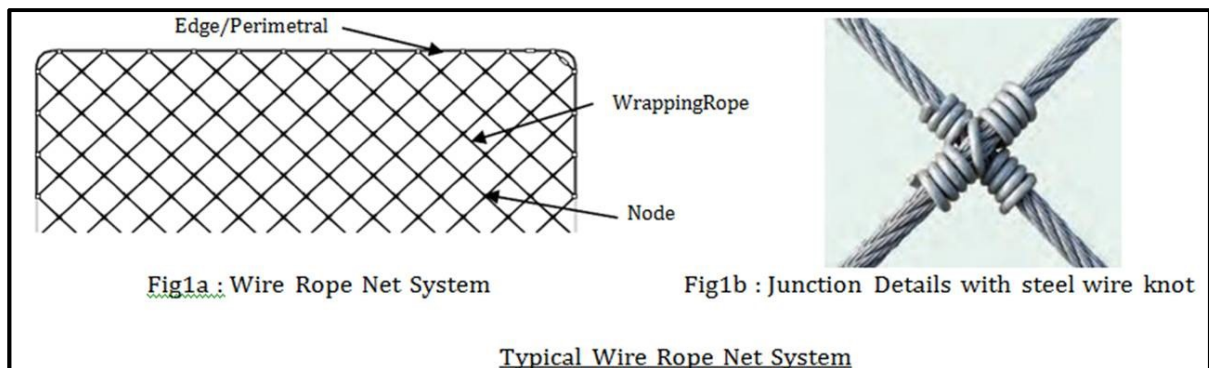

Components of the System

Bearing Plate

Shape:	Square
Size [mm]:	200 x 200
Thickness [mm]:	10
Material:	S355J according to EN 10025-2

Border Ropes

Border rope \varnothing 10 mm	Diameter \varnothing 10 mm
6x19WSC, acc.IS 2266	
Tensile strength of single wire rope >1770 N/mm ² as per IS2266	
Wire finish Galvanized Class B EN 10244-	

Bill of Quantity

Item Description	Unit
Supply & installation of High Tensile Rope Net System having rope diameter of 10mm (steel core) with tensile strength of rope 1770 N/mm ² with the intersection of joints having minimum tear capacity of 28 kN and mesh opening of 300 x 300mm. Min. tensile strength of mesh is 275kN/m and a min. ultimate punch load of mesh is 400kN. The system shall include top and bottom support rope, lacing wire or rope required to connect the panels and all accessories such	Sq.m

as U clamps, thimbles as shown in drawings and as per technical specifications.

Rockfall Protection System with Tensile Strength: 175 kN

The following performance specification describes a rolled cable net/high tensile rope net system, consisting of a mesh cover, rock or soil nailing, and connecting resp. boundary elements. The high tensile rope net system shall be tested by independent institutes such as IIT, THDC in a testing facility as per ETA (European Technical Approval) Standard. Only ETA certified wire meshes will be accepted.

Minimum specifications of the High Tensile Rope Net System

Mesh Shape:	rhomboidal/rectangular
Max opening of mesh (mm):	400 x 400 mm
Min wire rope dia. (mm) as per IS 2266:	10
Min tensile strength of rope (N/mm ²) as per IS 2266/ISO2408:	1770
Breaking strength of rope (kN) as per IS2266:	71
Construction of Rope as per IS 2266:	6 x7 WSC
Min tensile Strength of mesh (kN/m):	175
Punching Resistance (kN):	375
Coating as per EN 10244-2:	Standard Zn Class B/ Class A
Min tearing resistance of knot (kN):	28
Corrosion Protection of Knotting Wire:	95%Zn/5%Al

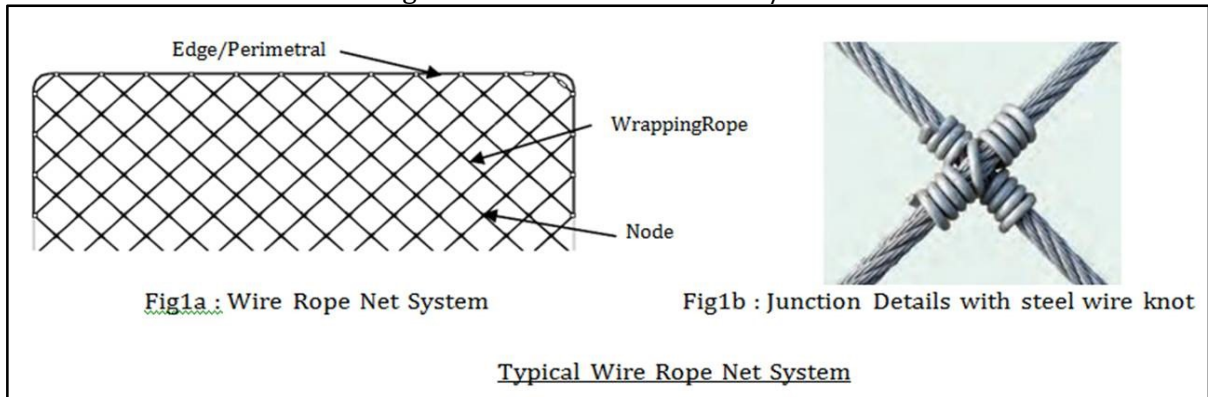

Components of the System

Bearing Plate

Shape:	Square
Size [mm]:	200 x 200
Thickness [mm]:	10
Material:	S355J according to EN 10025-2

Border Ropes

Border rope ø 10 mm	Diameter ø 10 mm
6x19WSC, acc.IS 2266	
Tensile strength of single wire rope >1770 N/mm ² as per IS2266	
Wire finish Galvanized Class B EN 10244-2	

Bill of Quantity

Item Description	Unit
Supply & installation of High Tensile Rope Net System having rope diameter of 10mm	

(steel core) with tensile strength of rope 1770 N/mm² with the intersection of joints having minimum tear capacity of 28 kN and mesh opening of 400 x 400mm. Min. tensile strength of mesh is 175kN/m and a min. ultimate punch load of mesh is 375kN. The system shall include top and bottom support rope, lacing wire or rope required to connect the panels and all accessories such as U clamps, thimbles as shown in drawings and as per technical specifications.

Sq.m

Rockfall Protection System with Tensile Strength: 150 kN

The following performance specification describes a rolled cable net/high tensile rope net system, consisting of a mesh cover, rock or soil nailing, and connecting resp. boundary elements. The high tensile rope net system shall be tested by independent institutes such as IIT, THDC in a testing facility as per ETA (European Technical Approval) Standard. Only ETA certified wire meshes will be accepted.

Minimum specifications of the High Tensile Rope Net System

Mesh Shape:	rhomboidal/rectangular
Max opening of mesh (mm):	300 x 300 mm
Min wire rope dia. (mm) as per IS 2266:	8
Min tensile strength of rope (N/mm ²) as per IS 2266/ISO2408:	1770
Breaking strength of rope (kN) as per IS2266:	45
Construction of Rope as per IS 2266:	6 x7 WSC
Min tensile Strength of mesh (kN/m):	150
Punching Resistance (kN):	265
Coating as per EN 10244-2:	Standard Zn Class B/Class A
Min tearing resistance of knot (kN):	28
Corrosion Protection of Knotting Wire:	95%Zn/5%Al

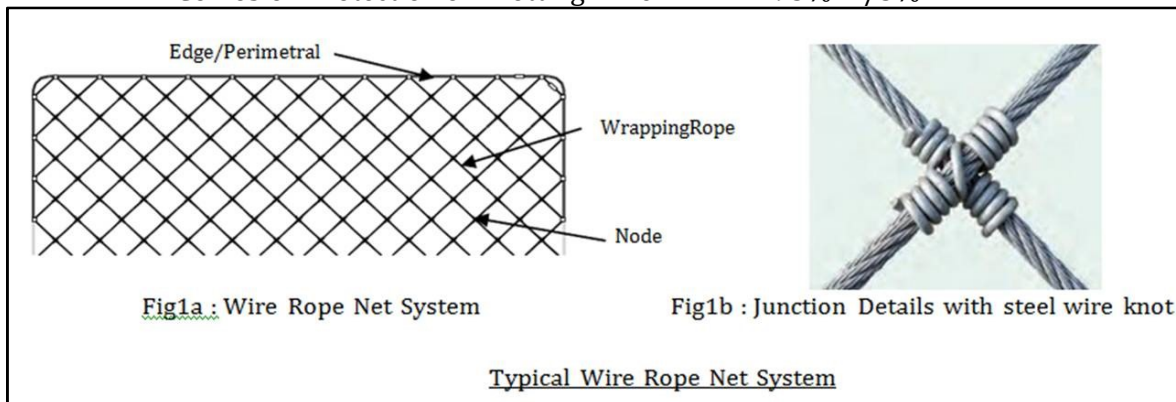

Fig1a : Wire Rope Net System

Fig1b : Junction Details with steel wire knot

Typical Wire Rope Net System

Components of the System

Bearing Plate

Shape:	Square
Size [mm]:	200 x 200
Thickness [mm]:	10
Material:	S355J according to EN 10025-2

Border Ropes

Border rope ϕ 10 mm	Diameter ϕ 10 mm
6x19WSC, acc.IS 2266	
Tensile strength of single wire rope >1770 N/mm ² as per IS2266 Wire finish Galvanized Class B EN 10244-2	

Bill of Quantity

Item Description	Unit
Supply & installation of High Tensile Rope Net System having rope diameter of 8mm	

(steel core) with tensile strength of rope 1770 N/mm ² with the intersection of joints having minimum tear capacity of 28 kN and mesh opening of 300 x 300mm. Min. tensile strength of mesh is 150kN/m and a min. ultimate punch load of mesh is 265kN. The system shall include top and bottom support rope, lacing wire or rope required to connect the panels and all accessories such as U clamps, thimbles as shown in drawings and as per technical specifications.	Sq.m
--	------

0
Rockfall Protection System with Tensile Strength: 100 kN

The following performance specification describes a rolled cable net/high tensile rope net system, consisting of a mesh cover, rock or soil nailing, and connecting resp. boundary elements. The high tensile rope net system shall be tested by independent institutes such as IIT, THDC in a testing facility as per ETA (European Technical Approval) Standard. Only ETA certified wire meshes will be accepted.

Minimum specifications of the High Tensile Rope Net System

Mesh Shape:	rhomboidal/rectangular
Max opening of mesh (mm):	400 x 400 mm
Min wire rope dia. (mm) as per IS 2266:	8
Min tensile strength of rope (N/mm ²) as per IS 2266/ISO2408:	1770
Breaking strength of rope (kN) as per IS2266:	45
Construction of Rope as per IS 2266:	6 x7 WSC
Min tensile Strength of mesh (kN/m):	100
Punching Resistance (kN):	250
Coating as per EN 10244-2:	Standard Zn Class B / Class A
Min tearing resistance of knot (kN):	28
Corrosion Protection of Knotting Wire:	95%Zn/5%Al

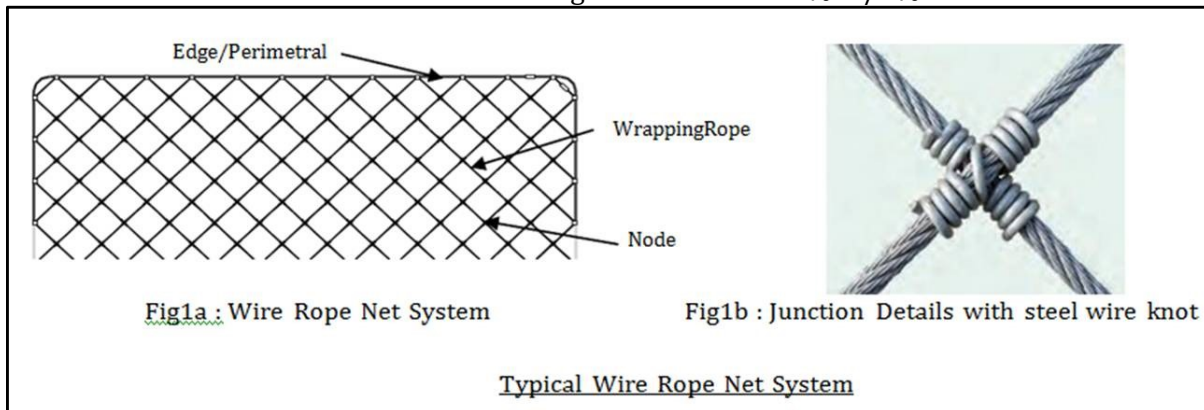

Components of the System

Bearing Plate

Shape:	Square
Size [mm]:	200 x 200
Thickness [mm]:	10
Material:	S355J according to EN 10025-2

Border Ropes

Border rope ø 10 mm	Diameter ø 10 mm
6x19WSC, acc.IS 2266	
Tensile strength of single wire rope >1770 N/mm ²	
	as per IS2266 Wire finish Galvanized Class B EN 10244-

2Bill of Quantity

Item Description	Unit
------------------	------

Supply & installation of High Tensile Rope Net System having rope diameter of 8mm (steel core) with tensile strength of rope 1770 N/mm ² with the intersection of joints having minimum tear capacity of 28 kN and mesh opening of 400 x 400mm. Min. tensile strength of mesh is 100kN/m and a min. ultimate punch load of mesh is 250kN. The system shall include top and bottom support rope, lacing wire or rope required to connect the panels and all accessories such as U clamps, thimbles as shown in drawings and as per technical specifications.	Sq.m
--	------

TESTING FACILITY

1. Scope

1.1 The following methods shall be used to sample and test wire rope net panels.

1.2 Characteristics Covered

- **Wire Rope:**The rope characteristics shall be verified as per the inspection documents of type 3.1 according to EN 10204/IS 2266 /ISO 2408 of incoming ropes and by additional tests on ropes according to EN 12385-1+A1/ IS 2266 /ISO 2408 and EN 13411-3+A1/ IS 2266 /ISO 2408.
- **Connection components:** The knot wires which forms the connection joint shall be inspected for diameter,coating type and mass of coating According to IS280/IS4826 (Al5%Zn95).
- **Crossing connection:** The tear breaking forces &the slipping forces of the wire Rope Connections shall be tested according to the ISO 17746: 2016 & ETA.
- **Wire rope mesh size:**The wire rope mesh sizes shall be measured according to ISO 17746: 2016/ETA and shall be in line with the manufacturer specification.
- **Tensile strength and elongation of net:**The tensile strengths of nets shall be tested according to ISO 17746: 2016.
- **Punching resistance and deflection of net:**The Punching resistance and deflection of nets shall be tested according to ISO 17746: 2016.
- **Durability:**Neutral salt spray test of non-ferrous metallic coated net samples according to ETA should not show more than 5 % of DBR (Dark Brown Rust).
-

2. Determining Punching Resistance and deflection of Net:

2.1 Apparatus:

- 2.1.1 The test piece should be loaded at the intersection of its diagonals (center of test piece), moving the press with a speed not greater than 10 mm/s.
- 2.1.2 The test consists in loading a sample of net perpendicularly to its plane by means of hemispherical shaped load bearing device and shall be able to test up to 800 kN with minimum panel size of 3m x3m.
- 2.1.3 The radius of curvature of the press should be 1200 mm and the maximum diameter of the specimen projected on the plane should be 1000 mm. The surface of the press shall be smooth, without any corners. Any attachment devices fitted on the surface of the press shall not interfere in any way with the test piece during the test.
- 2.1.4 The punching test shall be carried out after fixing the test piece to a rigid frame and it is aimed at measuring the force-movement curve of the central point of the press measured perpendicularly to the plane of the test piece. The panel should be considered to have failed when it is no longer able to support any increase to the applied force. The puncturing strength of a test piece is therefore defined as the

maximum force imparted by the test piece during the test.

- 2.1.5 All the perimeter nets of the test piece shall be fixed to the frame by means of the constraining devices e.g., Shackles, connecting links, steel ropes or other methods. However, the means of constraint shall not interfere with the structural behavior of the test piece of a size suitable to obtain the planarity of the test piece before starting the test by using either specific devices (e.g., screw tensioners) or frames with variable shapes.

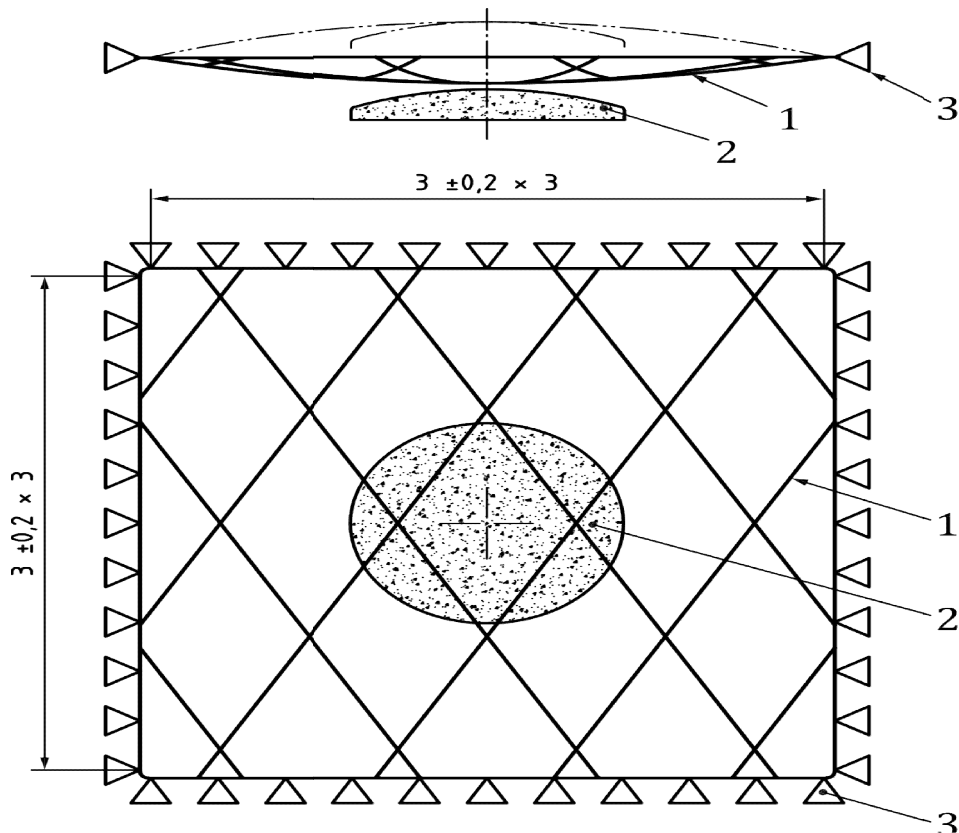

Key Components

- 1 Net
- 2 Press
- 3 Perimeter constraining device

2.2 Measurements and observations:

The origin of the load-movement diagram shall be measured from the plane holding the panel constraining devices. The following measurements shall be taken continuously during the test: — force exercised by the press; — movement of the press relative to the reference plane. The force shall be measured by class 1 load cells, in accordance with ISO 376/ISO 7500-1:2018.

2.3 Test report

The test report must provide the following information, and give an accurate description of test piece (construction materials and relative strengths, construction characteristics, geometrical characteristics of mesh, etc.)

- 2.3.1 Nominal dimensions of test piece and actual dimensions under test conditions.
- 2.3.2 Description of instrumentation used and temperature during the testing;
- 2.3.3 Detailed description of the test piece constraining condition, complete with photographic documentation;
- 2.3.4 Maximum sag be reached at the start of the test in those cases in which it may be measured;
- 2.3.5 Detailed description of boundary conditions;
- 2.3.6 Description of failure mode.
- 2.3.7 Actual failure load and relative stroke;
- 2.3.8 Load-Displacement relationship;
- 2.3.9 Photographic documentation of the test piece before and after the test.

3. Determining Net Tensile Strength (Longitudinal Tensile Test with no Lateral Contraction)

- 3.1 The test determines the actual longitudinal tensile strength and transversal tensile strength, and the relative elongation of wire rope net panel.
- 3.2 For this purpose, a frame made of four steel beams, one of which is free to slide in the direction of the load (longitudinal direction) shall be used.
- 3.3 The specimen shall have a width not less than 1 000 mm and a minimum area of 1,0 m². The specimen shall be fixed to the frame by means of lateral coupling devices, such as shackles or turnbuckles. The side coupling device shall be free to slide along the longitudinal beams.
- 3.4 The test frame must be equipped with load cells in order to acquire the load applied and the overall side reaction (longitudinal and transversal reactions).
- 3.5 The rate of longitudinal elongation during the test shall be between 6 mm/min and 10 mm/min. The test ends when the specimen broken load or the maximum applicable load is reached.
- 3.6 The specimen broken load is reached when the specimen is no longer able to support any increase of the applied force. It is also allowed to perform the test without reaching the rupture of the test, in which case, the tensile strength corresponds to the maximum load reached during the test.

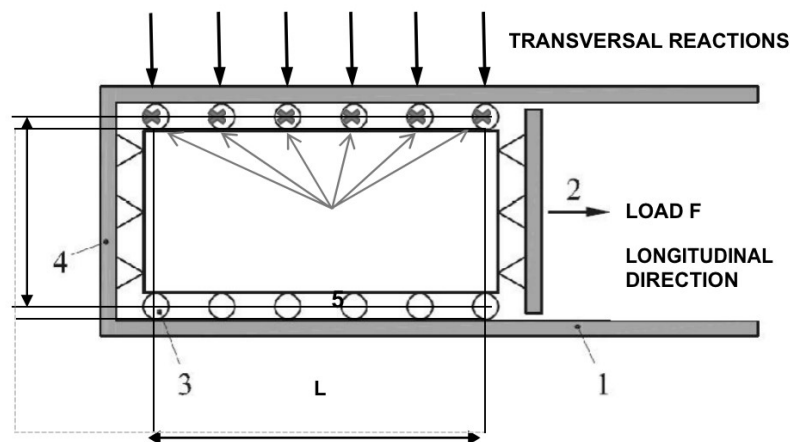

Key Components:

- 1. Fixed frame
- 2. Movable beam
- 3. Lateral constraint (movable in longitudinal direction) to which the net is connected
- Note – The number of lateral constraint depends on the configuration of sample
- 4. Side connection
- 5. Load cells to measure transversal reactions

Test Set-up

3.7 Test report

The test report must contain a full description of the specimen (the base materials and their strengths, construction details, geometric characteristics of the net), Longitudinal strength vs. displacement of movable beam diagram.

- i. Full description of sample (construction materials and relative strengths, construction characteristics, geometrical characteristics, technical details, etc.);
- ii. Identification of the test method used;
- iii. Nominal dimensions of test piece;
- iv. Detailed description of the test piece constraining condition, complete with photographic documentation;
- v. Detailed description of the failure mode;
- vi. Actual tensile strength and maximum elongation;
- vii. load - displacement diagram;
- viii. Photographic documentation of the test piece before and after the tests;
- ix. Description of instrumentation used and temperature during test.

