



TECHFAB INDIA INDUSTRIES LIMITED
At the Heart of Geosynthetic Activity

Indigenous Geosynthetics for a World-class Built Environment and Infrastructure in India

Compendium of TechFab India Case Studies (Volume I)

(Retaining Structures, Reinforced Soil Walls and Slopes & Hydraulic Applications)





Download TechFab India Mobile App now !!



TechFab India Industries Ltd.

712, Embassy Centre, Nariman Point,
Mumbai - 400021

 91 - 22 - 2287 6224

 info@techfabindia.com

 www.techfabindia.com

About TechFab India Industries Ltd.

One of the underpinnings of modern civilization is the quality of its built environment including buildings, transportation infrastructure, water resources management, waste management, protection from natural disasters etc. In recent years, in addition to the quantity and quality of built environment, we are increasingly concerned about its sustainability. Historically civil engineers have used various materials like earth, stone, timber, concrete, metals, bitumen etc. for construction. Over the last few decades, a new class of materials is enabling engineers to design and implement efficient, economic and environment-friendly solutions to a wide range of problems in civil engineering and related fields – **Geosynthetics**.

Geosynthetics are fabrics, grids, nets, strips or sheets etc., manufactured from polymeric materials and used with soil, rock or other geomaterials as part of a manmade project, structure or system. The use of geosynthetics had a profound impact on civil engineering practice - a veritable revolution in civil engineering. Today, geosynthetics are increasingly becoming an essential component of most projects - from transportation to real estate, from water resources to waste management, from river and canal bed and bank protection to coastal protection and land reclamation, from erosion control to landslide mitigation, from mining to power and heavy industries. Solutions using geosynthetics are usually more economical, more efficient and durable, easier and faster to construct and sustainable.

India has ambitious plans for the growth of our economy, for reducing poverty and generating employment and for increasing the quality of life of our people. A large number of projects are being planned and executed for building a world-class transportation infrastructure, developing sites for residential and commercial buildings, expanding irrigation network, waste management, protecting our long coastline against erosion, Mitigation of natural disasters like floods and landslides, expansion in mining, power and heavy industries etc. There is a huge scope for the use of geosynthetics in all these projects for designing and implementing reliable, economic and sustainable solutions which can help to increase safety, serviceability and durability, reduce both initial and life cycle costs, facilitate easier and faster construction and enhance sustainability.

A major constraint for the adoption of geosynthetics on a large scale in India was the need to import most of the products. However, recent years have seen a huge increase in indigenous manufacturing capabilities. In this, the lead has been taken by TechFab India Industries Ltd., the largest manufacturer of geosynthetics in India. Over the last 15 years, we have taken great strides to boost the indigenous capabilities and capacities for manufacturing geosynthetics. Today we produce an extremely wide range of world-class geosynthetics, in our state-of-the-art high capacity manufacturing facilities, located in Silvassa and Daman in the Union Territory of Dadra & Nagar Haveli.



About TechFab India Industries Ltd.

Having successfully met the challenge of ensuring adequate supplies of world-class indigenously manufactured geosynthetics for the growing needs of the rapidly expanding infrastructure sector, we are expanding our business to serve the needs of geohazard mitigation. The effects of climate change and associated extreme rainfall events are triggering geohazards on an unprecedented scale, threatening lives, livelihoods, lifelines and property. We have focused on the development of new range of products to facilitate engineered structural measures for geohazard mitigation. TechFab India has established a state-of-the-art manufacturing facility at Haridwar, Uttarakhand to produce a new line of engineered high performance products made from high quality steel, which have extensive applications in slope stabilization and rockfall protection.

Our major strengths include:

- We manufacture an extremely wide range of products: uniaxial, biaxial and high strength geogrids and links, woven and nonwoven geotextiles, reinforced nonwoven geotextiles, geostrips, prefabricated vertical drains, geocomposite drains, geocells, gabions, geotextiles bags and tubes, high tensile rope net, slope mesh & self drilling anchors.
- Our products are manufactured from the finest quality raw materials using state-of-the-art plant and subject to stringent quality control at all stages and are comparable to the best in the world in terms of quality and performance. The products are regularly tested in our three state-of-the-art in-house test facilities which are accredited by NABL a GAILAP and also in several independent accredited laboratories in India and overseas.
- We have very large installed capacities for all the products to cater to India's growing demand for geosynthetics & geohazard mitigation products.
- Our products have proved their mettle in numerous challenging projects in India a more than 35 countries all over the globe.
- We have dedicated teams for providing sales and technical support to our customers, owners, consultants and contractors.

We have put together this compendium of select case histories to highlight the vast range of products, diverse fields of application, immense scope for innovation and the numerous advantages and benefits of using geosynthetics. We hope that owners, consultants, contractors will benefit from these case studies and will be encouraged to use geosynthetics in more and more projects with greater confidence. We also hope that these success stories will give more confidence to officials of various ministries and government departments and professional associations to include geosynthetics in various standards, specifications, codes and guidelines. Lastly, we believe this compendium will also benefit researchers, teachers and students by giving them an understanding how geosynthetics are used to solve practical problems.

The case studies are arranged application wise - Erosion Protection, Reinforced Soil Walls & Slopes, Embankment over soft soil, Rockfall Protection & Hydraulic Applications. We have also mentioned the products used in the same index which will help to identify case studies for a particular product. We invite you to browse through this collection and hope these case studies will give an insight into the immense potential of geosynthetics.

We will be updating this collection from time to time by adding more case studies. We welcome your valuable comments, suggestions and feedback. You are also invited to visit our website for more details on products and also to contact us through email or phone for any specific assistance.



TFI Applications



Contact us:

Tel: + 91- 22 - 2287 6224 / 6225

E: info@techfabindia.com

For Other Applications, please refer Volume II

(Roads, Railways & Other Geotechnical Applications)

TFI Products



BIS
Approved

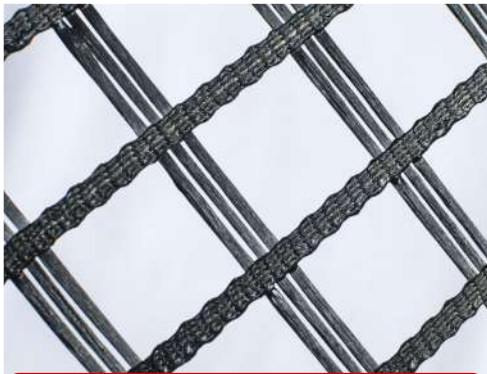

TechGrid Polyester Uniaxial Geogrid

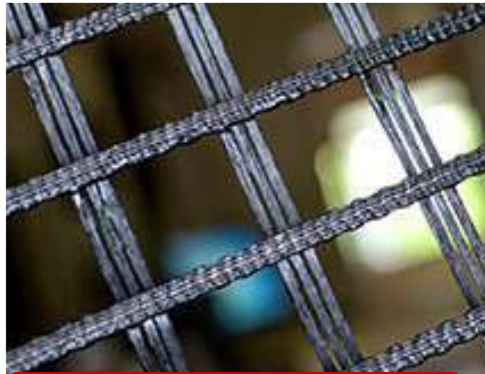

TechGrid Polyester Biaxial Geogrid



TechLink High Strength Geogrid



TechGrid PP Biaxial Geogrid



Techcell Geocell



TechGeo Nonwoven Geotextile



TFI Woven Geotextile



TechDrain Drainage Composite

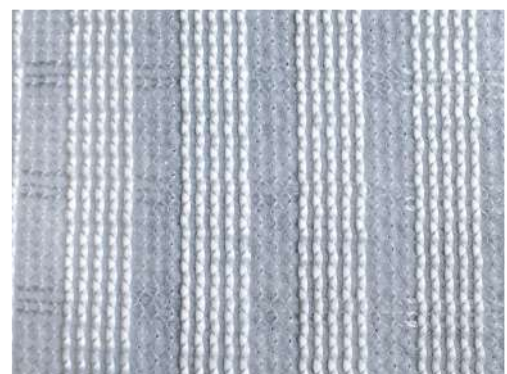

TGC - Reinforced Nonwoven Composite

TFI Products



BIS
Approved

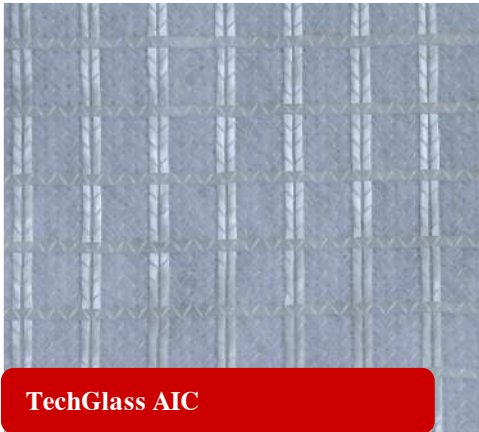

TechGlass AIC



TechStrap Polyester Strap

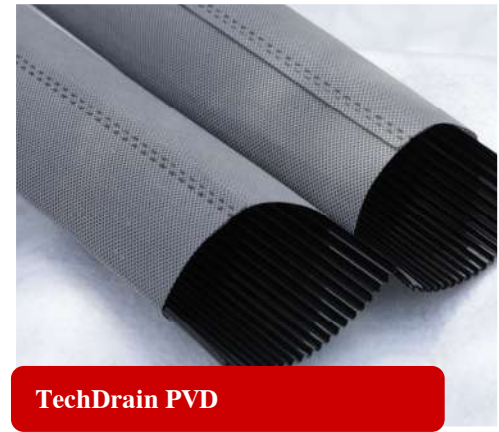

TechDrain PVD



Tech GeoMattress



Tech Fibre - PP Staple Fibre



TechFab Metal Gabion

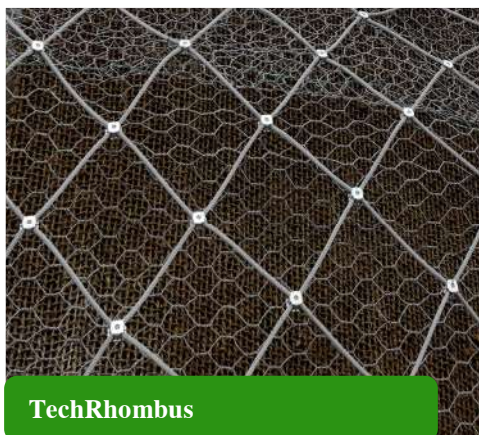

TechRhombus



TechSlope Mesh



TechAnchor - Self Drilling Anchor

INDEX

SL. NO.	NAME OF CASE STUDY	PAGE NO.
A. Erosion Protection over Stable Slope		
Products: GEOCELL - Techcell Geocell, TGU - Techgrid PET Uniaxial Geogrid, PPBG - Techgrid PP Biaxial Geogrid		
001-EP-GEOCELL	Slope Erosion Control using Techcell Geocell at UAE	01 - 04
002-EP-GEOCELL	Slope Erosion Control using Geocell for Road Embankment of Ahmedabad - Vadodara Expressway, Gujarat	05 - 08
003-EP-PPBG	Slope Protection work using PP Biaxial Geogrid for Six lane Access Controlled Highway (NH-152 D), Haryana	09 - 12
004-EP-GEOCELL	Slope Erosion Control using Geocell for Road Embankment of NH-82 at Nalanda, Bihar	13 - 16
005-EP-GEOCELL	Embankment Protection of National Highway with Geocell for Tharad - Dhanera - Panthwada Section of NH-168, Gujarat	17 - 21
006-EP-TGU	Erosion protection works at ESR Industrial & Logistic park, Chakan, Pune, Maharashtra	22 - 26
B. Reinforced Soil Slopes / Embankment over Soft Soil		
Products: TGU - Techgrid PET Uniaxial Geogrid, PWGTX - Polyester Woven Geotextile, PPWGTX - Polypropylene Woven Geotextile, NWGTX - TechGeo - Nonwoven Geotextile		
007-RSS-TGU/GAB/NWGTX	Reinforced Soil Slope at Shillong Bypass connecting NH-40 to NH-44, Meghalaya	27 - 33
008-RSS-TGU/NWGTX	Construction of Reinforced Soil Wall with Wrap around and Vegetated facia near Tunnel No:1 at Katra, Jammu & Kashmir	34 - 38
009-RSS-TGU/NWGTX	Reinforced Soil wall with Welded wire mesh facing to retain the approaches to a flyover at DND - Mayur Vihar Link Road Phase I & II, New Delhi	39 - 42
010-RSS-TGU/NWGTX	Reinforced Soil wall with Welded wire mesh facing for construction of approaches for coal handling area and hopper pit and tunnel for the power plant at Wardha, Maharashtra	43 - 46
011-EOSS-TGU/PPWGTX	Construction of Embankment using TFI 5200 Tape Woven Geotextile & TGU 40 Techgrid Geogrids at IT Corridor in Chennai	47 - 49
012-EOSS-PPWGTX	Construction of Embankment using TFI 5200 Tape Woven Geotextile at Calicut Bypass, Kerala	50 - 51
013-EOSS-PWGTX	Construction of Embankment using High Strength Polyester Woven Geotextile TFI 3200 for approaches of Rajiv Gandhi Setu Bridge connecting Nani Daman & Moti daman in UT of Daman	52 - 53
C. Gabion Gravity Retaining Walls		
Products: GAB - TechFab Metal Gabion, NWGTX - TechGeo - Nonwoven Geotextile		
014-GRW-GAB/NWGTX	Construction of Gabion Retaining Wall for shore protection works at Nigeria	54 - 57
015-GRW-GAB/NWGTX	Construction of Gabion Retaining Wall for Aldeia De at Bambolim Beach, Goa	58 - 61
016-GRW-GAB/NWGTX	Construction of Gabion Retaining Wall and Gutter for high velocity water-way at Mandhardevi, Satara, Maharashtra	62 - 64
017-GRW-GAB/NWGTX	Construction of Pipe culvert by using TechFab metal gabions at Ghana, South Africa	65 - 67
018-GRW-GAB/NWGTX	Construction of Gabion retaining wall at Beawar Pali, Rajasthan	68 - 71
019-GRW-GAB/NWGTX	Construction of Gabion retaining wall to SH-130 Pachgaon to Kandalgaoon Road ODR-90, at Karveer, Kolhapur, Maharashtra	72 - 74
020-GRW-GAB/NWGTX	Earth Retention & Protection Works at Four Laning of Hazaribagh Ranchi section of NH-33, Jharkhand under NHDP Phase – III, Jharkhand	75 - 77

021-GRW-GAB/NWGTX	Gabion Wall for Bank Protection Work and Flood Control measure for Madhumati and Bonar Nallah, Srinagar	78 - 80
022-GRW-GAB/NWGTX	Construction of gabion Retaining Wall for Rajkamal Site at Juhu Beach, Mumbai	81 - 84
D. Gabion Fascia Reinforced Soil Walls		
Products: GAB - TechFab Metal Gabion, GABMAT - TechFab Metal Gabion Mattress, TSTRAP - TechStrap, NWGTX - TechGeo - Nonwoven Geotextile, TGU - Techgrid PET Uniaxial Geogrid		
023-RSW-GAB/ GABMAT/TSTRAP/ NWGTX	Reinforced Soil Structure to support BOW String bridge at Kondapochamma Sagar Reservoir, Kaleshwaram, Telangana	85 - 89
024-RSW-GAB/ GABMAT/TGU/NWGTX	River bank protection & Land reclamation with Techfab Metal Gabion Reinforced Soil Wall for INEOS Starlution at Katol village, Gujarat	90 - 95
025-RSW-GAB/ GABMAT/TGU/NWGTX	River bank protection work at Orsang river with Techfab metal gabion reinforced soil wall for BAPS Temple, Bodeli, Gujarat	96 - 99
026-RSW-GAB/ GABMAT/TGU/NWGTX	River training with gabion fascia reinforced soil wall for Gadhi river along Navi Mumbai International Airport, Navi Mumbai	100 - 105
E. Reinforced Soil Walls with Concrete Panel & Block		
Products: TGU - Techgrid PET Uniaxial Geogrid, NWGTX - TechGeo - Nonwoven Geotextile, TSTRAP - TechStrap		
027-RSW-TSTRAP	Reinforced Soil Wall for bridge approach and reconstruction of ROB 39A at Gondal railway portion, Gujarat	106 - 109
028-RSW-TGU/GAB/ NWGTX	Construction of Reinforced Soil Wall & Gabion retaining wall for Soil stabilization at Mudkhed, Maharashtra	110 - 112
029-RSW-TGU/NWGTX	Four Laning of Lucknow - Muzaffarpur Section on NH-28, Civil contractor package No. LMNHP EW-II (WB), Package 06 (KM 208.00 - KM 251.70)	113 - 115
030-RSW-TGU/NWGTX	Reinforced Soil Walls with Descrete panel facia system for Flyovers & ROB's of NH-76, EW-II (RJ-III), Udaipur, Rajasthan	116 - 118
031-RSW-TGU/NWGTX	Six Laning of Km 108+700 to Km 192+000 on Vadodara - Bharuch section of NH-8 in the state of Gujarat on BOT basis	119 - 122
032-RSW-TGU/NWGTX	Strengthening and Widening of road at Palanpur Swaroopgunj Package on NH-14, Gujarat	123 - 125
033-RSW-TGU/NWGTX	Four laning of Nagpur - Hyderabad section of NH-7 from KM. 123.000 TO 153.000, Contract Package No. NS-61, Maharashtra	126 - 128
034-RSW-TGU/NWGTX	Construction of Eight Lane Access Controlled Expressway as outer ring road to Hyderabad city, Phase-II Pedda Amberpet (KM. 95.000) to Bongulur (KM. 108.000) , Andhra Pradesh	129 - 131
035-RSW-TGU/NWGTX	Construction of Flyover at Nana Varchha on Varchha road in Surat, Gujarat	132 - 135
036-RSW-TGU/NWGTX	Reinforced Soil Walls and Slope Protection measures at Statue of Unity, Gujarat	136 - 142
037-RSW-TGU	Reinforced Soil Wall for Monsoon Palace, Aamby Valley, Maharashtra	143 - 147
038-RSW-TGU/TGB/ GAB/NWGTX	Reinforced Soil Wall at Bungalow Villa Premises, Lonavala, Maharashtra	148 - 151
039-RSW-TGU	Reinforced Soil Wall for a Private Bungalow in Aamby Valley Lonavala, Maharashtra	152 - 154

F. Rockfall Protection		
Products: TRFNETTING - TechFab Rockfall Netting, TechRhombus, GAB - TechFab Metal Gabion		
040-RP-TRFNETTING/TR/GAB	Rockfall Protection works near the road adjacent to Bio-Diversity Park , HiTech City, Hyderabad of TSIIC Cyberabad zone, Telangana	155 - 160
041-RP-TRFNETTING	Rockfall Protection work at Jorabat - Shillong section of NH-40 from km. 0+000 to km. 61+800, Assam & Meghalaya	161 - 166
G. River & Canal Bed / Bank Protection, Flood Control		
Products: GTX BAG - TechFab Geotextile Bags, GAB - TechFab Metal Gabion, GABMAT - TechFab Metal Gabion Mattress, NWGTX - TechGeo - Nonwoven Geotextile, TGU - Techgrid PET Uniaxial Geogrid, TGM - Tech GeoMattress		
042-BP-TGM	Flood Mitigation & River bank protection using Tech GeoMattress along Brahmaputra river bank, North Lakhimpur, Assam	167 - 170
043-BP-GAB/GABMAT/TGU/NWGTX	River bank protection & Land reclamation with Techfab Metal Gabion Reinforced Soil Wall for INEOS Starlution at Katol village, Gujarat	90 - 95
044-BP-NWGTX	Slope Protection of Swan river in the state of Himachal Pradesh using Techgeo PN 30 as geotextile filter cloth	171 - 173
045-BP-GTX BAG/NWGTX	Protection works to eroding left bank of river Churni at Rabonbore for a length of 650m in Block Ranaghat, Nadia, West Bengal	174 - 177
046-BP-GAB/GABMAT/TGU/NWGTX	River bank protection work at Orsang river with Techfab metal gabion reinforced soil wall for BAPS Temple, Bodeli, Gujarat	96 - 99
047-BP-GABMAT/NWGTX	Reinforced Soil Walls and Slope Protection measures at Statue of Unity, Gujarat	136 - 142
048-BP-GAB/GABMAT/TGU/NWGTX	River training with gabion fascia reinforced soil wall for Gadhi river along Navi Mumbai International Airport, Navi Mumbai	100 - 105
049-BP-GTX BAG	Anti Erosion Measures for bank protection along the right bank at Bogdebri and left bank at Nishiganj of river Mansai at Coochbehar district in West Bengal	178 - 181
050-FC-GAB	Bank Protection Work and Flood Control measure for Madhumati and Bonar Nallah, Srinagar	78 - 80
051-FC-GTX BAG	Flood protection work on the downstream of river Sharda/Ghaghara, Lakhimpur, Uttar Pradesh	182 - 184
H. Coastal Protection, Sea Wall & Breakwater		
Products: GTX TUBE - TechFab Geotextile Tube, GTX BAG - TechFab Geotextile Bags, GABMAT - TechFab Metal Gabion Mattress, GEOCELL - Techcell Geocell, NWGTX - TechGeo - Nonwoven Geotextile		
052-CP-GTX TUBE	TechTube Geotextile Tubes for Protection of Existing Geotextile Tube protected island at Cheruvathur Fishery Harbour, Kasaragod, Kerala	185 - 189
053-CP-GTX TUBE	Protection & Reclamation work using GeotextileTube (TechTube) at Kattupalli, TamilNadu	190 - 194
054-CP-GTX TUBE	TechFab Techtubes for Protection of Shoreline and Restoration of Eroded beach at Dahanu in Maharashtra	195 - 197
055-CP-GTX TUBE	Reclamation & Nourishment for Devbagh beach, at Devbagh, Malvan, Sindhudurg, Maharashtra	198 - 201
056-CP-GTX BAG	Seawall Rehabilitation at Mukkachery, Mangalore	202 - 204
057-CP-GEOCELL/GABMAT/NWGTX	Shore Protection Works near Danka Temple from Dariya chowk to earth bank at Khambhat, Gujarat	205 - 211

TechFab India International Projects

REINFORCED SOIL WALL WITH TECHGRID GEOGRIDS - KOREA

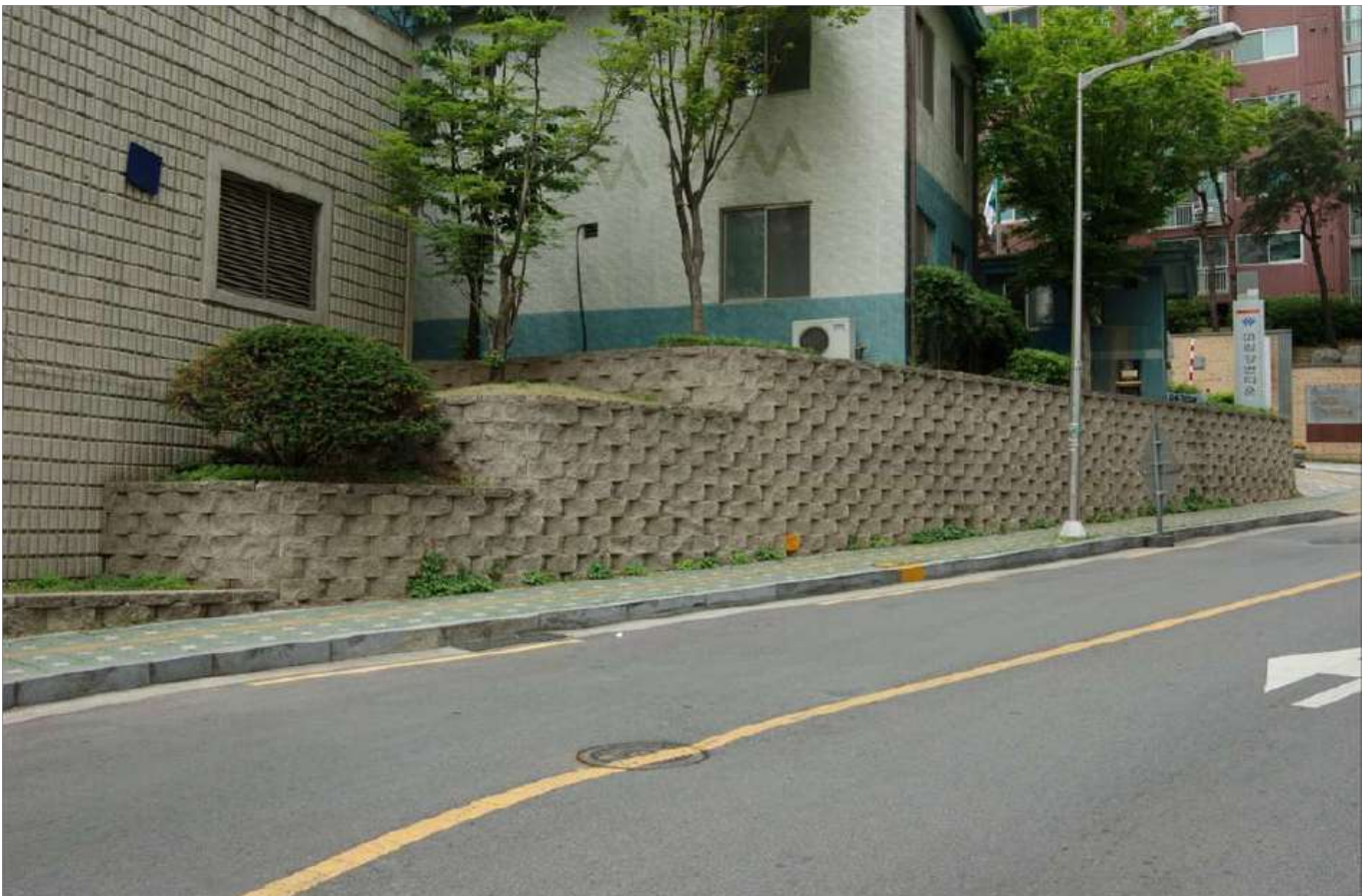

TechFab India International Projects

CONSTRUCTION OF PIPE CULVERT BY USING TECHFAB METAL GABIONS AT GHANA, SOUTH AFRICA



REINFORCED SOIL WALL WITH TECHGRID GEOGRIDS - KOREA



CASE HISTORY

Rev:00, Date : 16.12.2022



SLOPE EROSION CONTROL USING TECHCELL GEOCELL AT UAE

United Arab Emirates

Erosion Control & Slope Protection

Client:	Products used:
DUTCO TENNANT LLC, UAE	•TECHCELL GEOCELL (712 X 150mm TYPE) •TECHGEO PR20 GEOTEXTILE
Main contractor:	
Manufacturer & Supplier:	Year of Construction:
TECHFAB (INDIA) INDUSTRIES LTD.	2022

Problem:

Dutco Tennant had to be provided a solution to prevent erosion of the side slope near the road at UAE. They decided to go with some sustainable environmentally-friendly and ecologically-friendly solution which requires short construction period and low maintenance charges.

Solution:

TechFab India suggested slope protection with Techcell Geocell over the slope to prevent the soil erosion. Geocell is a light weight, strong and three-dimensional honeycomb shaped cellular confinement system. Using geocells to strengthen slopes is considered to be the most efficient solution to stabilize the soil and prevent the development of erosion processes. The type of Geocell recommended for this project was TechCell 712 x 150mm which is infilled with aggregate considering the height of slope, slope angle and soil properties.

This solution is in accordance with the provisions of Section 705 specifications of MoRTH 5th revision. By using geocell confinement system, the slope protection measures can be optimized in terms of thickness and further improve the performance of protection measures due to its confinement effect. The infilled geocells provide a stable layer of confined material over the slope surface. At the toe of the slope geocell was embedded in the soil.



Photo 1 : Installation of Techcell Geocell over the slope



Photo 2 : During Construction Photograph

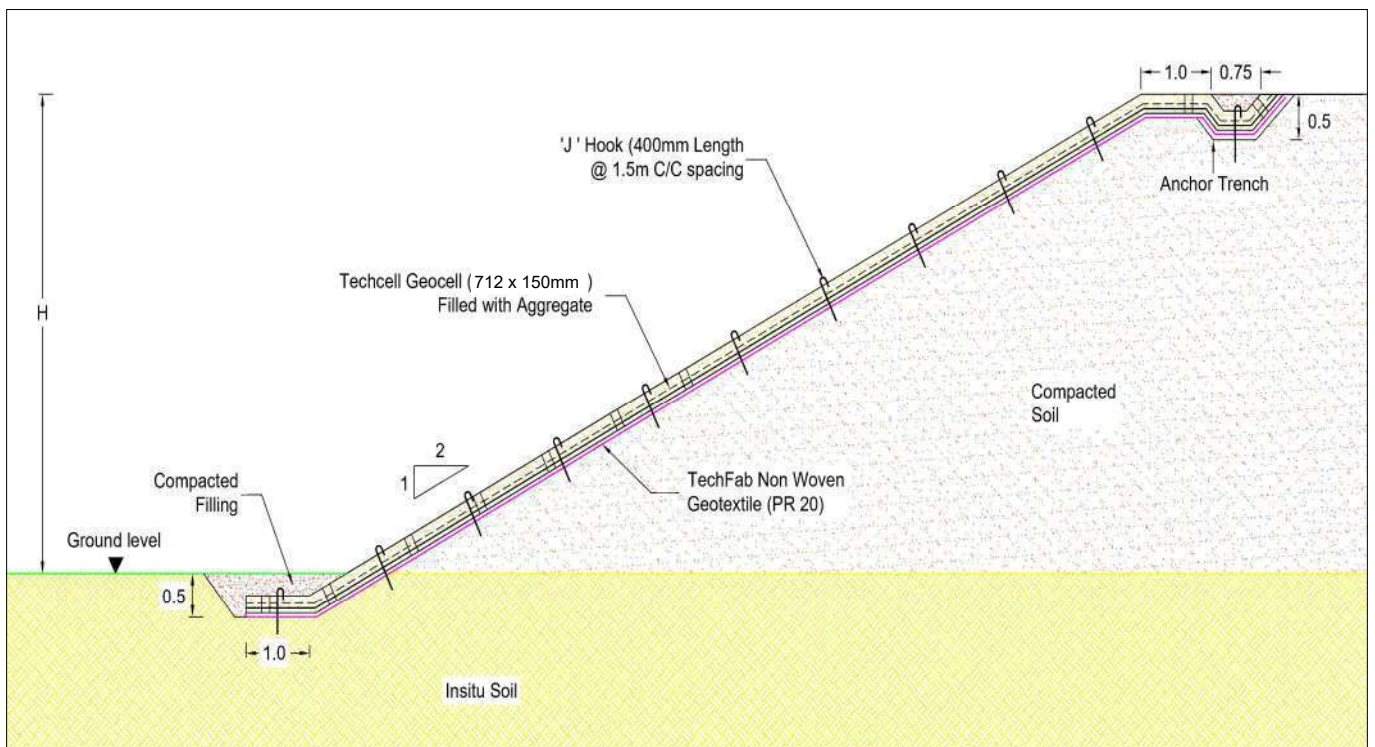

Typical Cross Section Drawing



Photo 3 : During Construction Photograph

Execution on site :

- Prepare slope surface. Remove debris, rocks, unacceptable soil from area where Geocell is to be laid.
- Replace removed soil with acceptable soil and compact earthwork.
- Excavate anchoring trench and toe trench according to drawings provided.
- Install J shaped anchors along anchor trench with proper alignment to hold Geocell section in place on the slope.
- Expand down the Geocell section on the slope and allow settling then fix end of Techcells by using J shaped anchors.
- Adjacent Geocell must be levelled with each other and tie with each other using cable string.
- Install J hooks at specified distance.
- When Geocell has been laid in place properly, it should be filled with specified material.
- Infill should be delivered either to top of slope or bottom of slope using a loader.

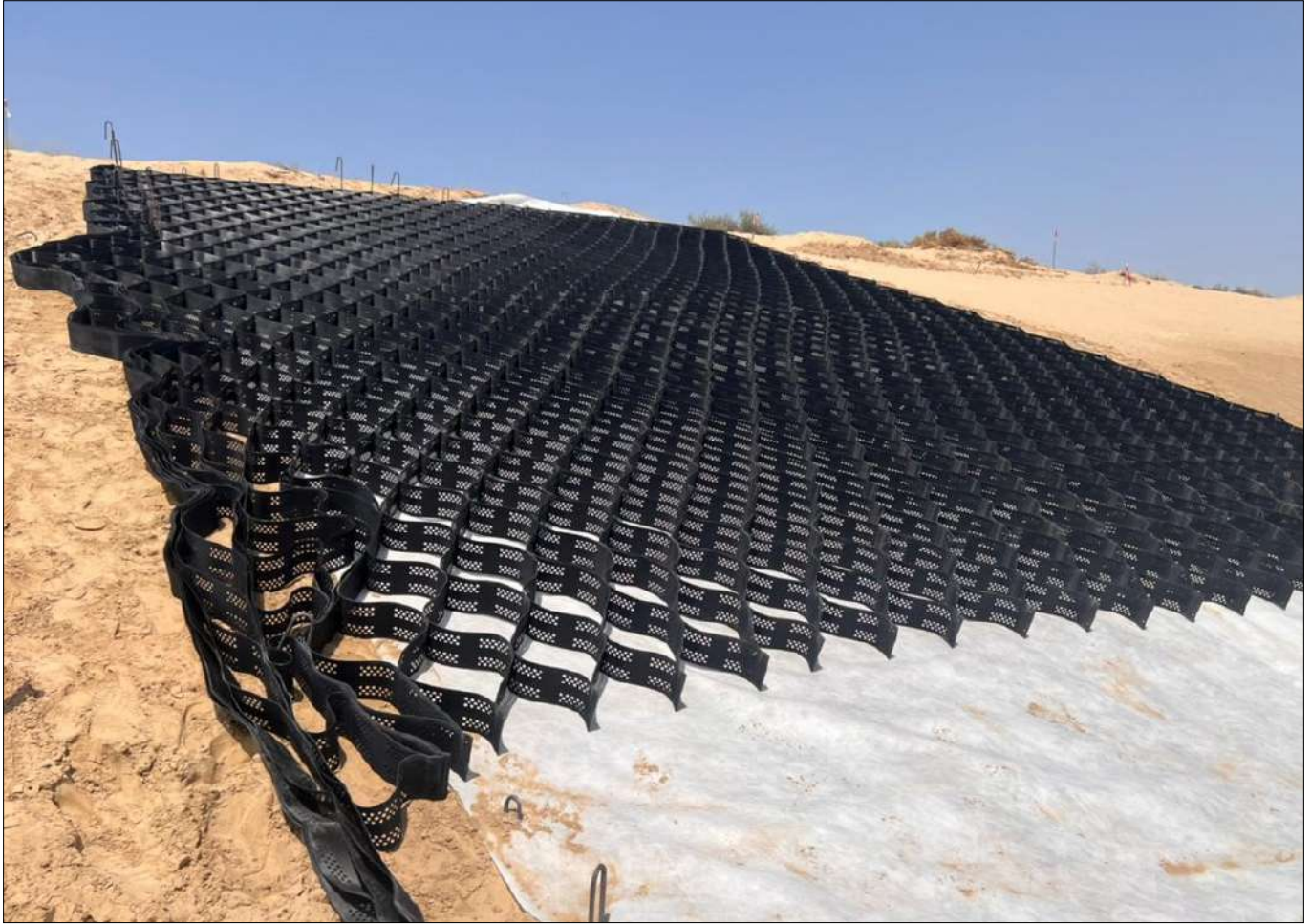

Photo 4 : During Construction Photograph

Present Status of the Project:

The Project is completed successfully and serving its purpose.

For further details kindly contact :

TechFab India Industries Ltd.

711/712, Embassy Centre, Nariman Point, Mumbai – 400021
Tel: + 91- 22 - 2287 6224 / 6225 Fax: + 91- 22 - 2287 6218
E: info@techfabindia.com
W: www.techfabindia.com

CASE HISTORY

Rev:00, Date : 09.06.2022

SLOPE EROSION CONTROL USING GEOCELL FOR ROAD EMBANKMENT OF AHMEDABAD - VADODARA EXPRESSWAY, GUJARAT

GUJARAT, INDIA



Erosion Control & Slope Protection

Client:	Products used:
NATIONAL HIGHWAYS AUTHORITY OF INDIA (NHAI)	• TFI TECHCELL GEOCELL (712 X 75 TYPE) • TECHGEO PR20 GEOTEXTILE
Main contractor:	
L & T	
Manufacturer & Supplier:	Year of Construction:
TECHFAB (INDIA) INDUSTRIES LTD.	2022

Problem:

The National Highways Authority of India (NHAI) is upgrading the highway system in various stretches along Ahmedabad – Vadodara Expressway in the state of Gujarat.

Highway embankments are an integral part of the motorway to maintain the finished road levels. In this project, the embankments are provided with 1:1.5 (V:H) side slopes for the stability of embankment. Erosion of slopes of road embankment due to rainfall and surface runoff of precipitated water is one of the major problems that need to be addressed during the construction of highways / road embankments. If neglected, the progressive erosion of slopes may lead to overall instability of the slope of road embankment affecting the service life and performance of the road pavement too. National road construction guidelines recommend surface protection in any case where there is a chance of surface erosion.

Solution:

Conventionally, concrete lining / 300mm stone pitching are used for the slope erosion protection. TechFab India suggested used of Techcell Geocell of 712 x 100mm type, which is infilled with vegetative soil as an appropriate solution for effectively protecting the embankment slope as Geocell is cost-effective, long lasting and eco-friendly. This solution is in accordance with the provisions of Section 705 specifications of MoRTH 5th revision. By using geocell confinement system, the slope protection measures can be optimized in terms of thickness and further improve the performance of protection measures due to its confinement effect. The infilled geocells provide a stable layer of confined material over the slope surface. They promote vegetation growth to provide a green surface which also protects against erosion. At the toe of the slope geocell was embedded in the subgrade. A collecting drainage system was also constructed which comprised of Geocells infilled with concrete over Non-woven Geotextile to improve down-slope stability against high water flow.



Photo 1 : Installation of Techcell Geocell over the embankment slope



Photo 2 : Filling of vegetative soil in Techcell Geocell



Photo 3 : Slope after filling of vegetative soil in Techcell Geocell



Photo 4 : Construction of Drains lined with concrete filled Geocells

Execution on site :

- Prepare slope surface. Remove debris, rocks, unacceptable soil from area where Geocell is to be laid.
- Replace removed soil with acceptable soil and compact earthwork.
- Excavate anchoring trench and toe trench according to drawings provided.
- Install J shaped anchors along anchor trench with proper alignment to hold Geocell section in place on the slope.
- Expand down the Geocell section on the slope and allow settling then fix end of Techcells by using J shaped anchors.
- Adjacent Geocell must be levelled with each other and tie with each other using cable string.
- Install J hooks at specified distance.
- When Geocell has been laid in place properly, it should be filled with specified material.
- Infill should be delivered either to top of slope or bottom of slope using a loader.
- For vegetative slope, locally available vegetative soil should be utilized as infill. Vegetation grows naturally or can be implanted as required



Photo 5 : Grass was planted on finished surface of road embankment

Conclusion:

The Project is completed successfully and serving its purpose. The slopes are now green and aesthetically pleasing.

For further details kindly contact :

TechFab India Industries Ltd.

711/712, Embassy Centre, Nariman Point, Mumbai – 400021

Tel: + 91- 22 - 2287 6224 / 6225 Fax: + 91- 22 - 2287 6218

E: info@techfabindia.com

W: www.techfabindia.com

CASE HISTORY

Rev:00, Date : 18.09.2021

SLOPE PROTECTION WORK USING PP BIAXIAL GEOGRID FOR SIX LANE ACCESS CONTROLLED HIGHWAY (NH 152 D)

HARYANA, INDIA



Slope Protection

Client:

Products used & Quantity supplied:

Intercontinental Consultants and Technocrats Pvt.	TECHGRID PP BIAXIAL GEOGRID - 20 X 20 - 20000 SQM
Main contractor: M/S. HIMALAYAN INFRA CORP PVT. LTD.	
Manufacturer & Supplier: TECHFAB (INDIA) INDUSTRIES LTD.	Year of construction: JUNE 2021

Project brief:

227 km Trans-Haryana Expressway (NH-152D) or Gangheri – Narnaul Highway by NHAI is an under construction 4 lane access-controlled road with a route alignment connecting Ismailabad / Gangheri near Ambala with Narnaul in south Haryana.

This north-south greenfield expressway is being developed under Bharatmala Pariyojana as part of the 301 km Ambala – Kotputli Economic Corridor. Its sole objective is to reduce the distance and travel time between Ambala and Jaipur, and to provide an alternate route bypassing Delhi.

This expressway passes through 8 districts of Kurukshetra, Kaithal, Karnal, Jind, Rohtak, Bhiwani, Charkhi Dadri, and Mahendergarh. The road will connect NH-152 at Gangeri (near Ismailabad) and ends at Narnaul bypass near the Haryana-Rajasthan Border.

Solution proposed:

The Client mentioned the problem to TechFab India Industries Ltd. for the alternate solution related to slope protection as he was using Jute mat which was not easily available and geocell was consuming time for Installation. Ease and speed of construction was a key element in the design selection process. We have suggested the use of TechGrid polypropylene of 20 x 20 kN/m strength in (MD & CD) having aperture size of 38 mm x 38 mm for the protection work, this will provide the reinforcement to the slope and from its aperture the vegetation growth will be promoted.

The use of TechGrid not only increase the strength of sloping soil but also enables a reduction in the slope erosion which results saving in project and life cycle costs.

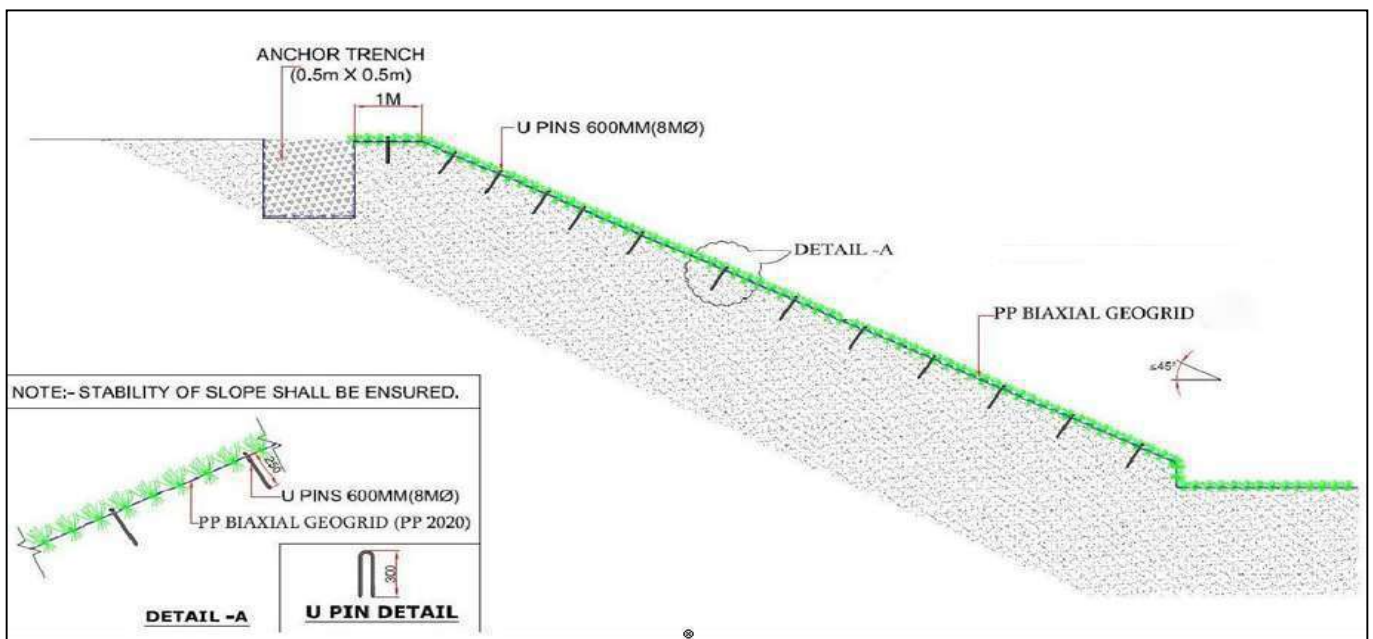

TYPICAL CROSSECTION



PLACEMENT OF GRASS OVER THE SLOPE



LAYING OF TECHGRID OVER THE SLOPE



PLANTATION GROWTH AFTER 2-3 MONTHS



SCENIC VIEW OF PLANTATION GROWTH OVER SLOPE USING TECHGRID

Conclusion:

The Slope protection work with TechGrid Geogrid completed as per the clients requirement and Client is happy with the solution we suggested, quality of Geogrids and timely supply of the materials. And the performance certificate related to the use of geogrid in slope has shown the interest of using new innovative solution which ease the project progress and reduce the project cost.



Intercontinental Consultants and Technocrats Pvt. Ltd.

Consultancy Service for Authority's Engineer for Supervision of Construction of 6 lane access controlled Greenfield highway from Junction with Jind-Safidon Road (SH-14) near Kheri Village to Junction with NH-334B (Charkhi Dahi-Jhajjar Section) near Charkhi Dahi (Ch. 80+000 to Ch. 105+000, length 85 km) in the State of Haryana on EPC mode under Bharatmala Package 5 (Rural/Urban/Highway/152D/A&P/eg2)

TO WHOM MAY IT CONCERN

This is to certify that M/s Techfab India Industries Ltd, Mumbai, have supplied the Biaxial Polypropylene Geogrid of 20 kN/m x 20 kN/m tensile strength having aperture size of 38mm x 38 mm for Haryana Trans Project for embankment slope protection work on 6 lane access-controlled Highway NH 152D- Package 5, Ch.108.000 to Ch. 131.000.

This product has helped to control the slope protection through reinforcing the soil and enhancing the growth of vegetation through its aperture.

The installation and methodology of this product is simple, easy and performs well at the site for the proposed work and we recommend to use this in further slope protection work.



Sourabh Singh
Team Leader
(Authority's Engineer NHA)



Innovative, Creative & Technologically Sustainable Infrastructure Solutions

City: Gurgaon, 122001, India
Corporate Office: A-8, Green Park, New Delhi 110006, India
Tel: +91-11-40863000 Fax: +91-11-26852532
Email: sou@ictonline.com
Website: http://www.ictonline.com



Info Office:
Intercontinental Consultant & Technocrats Pvt. Ltd.
House No. 1286, Indira Sector No. 3,
Kohala - 124001 (Haryana)
Tel: 01261-289326

PERFORMANCE CERTIFICATE

For further details kindly contact :

TechFab India Industries Ltd.

711/712, Embassy Centre, Nariman Point, Mumbai - 400021

Tel: + 91- 22 - 2287 6224 / 6225 Fax: + 91- 22 - 2287 6218

E: info@techfabindia.com

W: www.techfabindia.com

CASE HISTORY

Rev:00, Date : 08.03.2021

SLOPE EROSION CONTROL USING GEOCELL FOR ROAD EMBANKMENT OF NH-82 AT NALANDA, BIHAR NALANDA, BIHAR, INDIA



Erosion Control & Slope Protection

Client: NATIONAL HIGHWAYS AUTHORITY OF INDIA (NHAI)	Products used: • TFI TECHCELL GEOCELL - 712 X 100 TYPE • TECHGEO PR20 GEOTEXTILE
Main contractor: GR INFRAPROJECTS LTD.	
Manufacturer & Supplier: TECHFAB (INDIA) INDUSTRIES LTD.	Year of Construction: 2018

Problem:

Erosion of slopes of road embankment due to rainfall and surface runoff of precipitated water is one of the major problems that need to be addressed during the construction of highways / road embankments. If neglected, the continuous erosion of slopes may lead to overall instability of the slope of road embankment affecting the service life and performance of the road pavement.

Solution:

Conventionally, concrete lining / 300mm stone pitching is used for the slope protection. However, by using geocell confinement system, the slope protection measures can be optimized in terms of thickness and further improve the performance of protection measures due to its confinement effect. Considering the same, TechCell geocell of 712X100 type was adopted in this project with concrete infill. Since the concrete is used as infill material, a non-woven geotextile was used as separation and filtration layer below the geocell.



During Construction Photograph

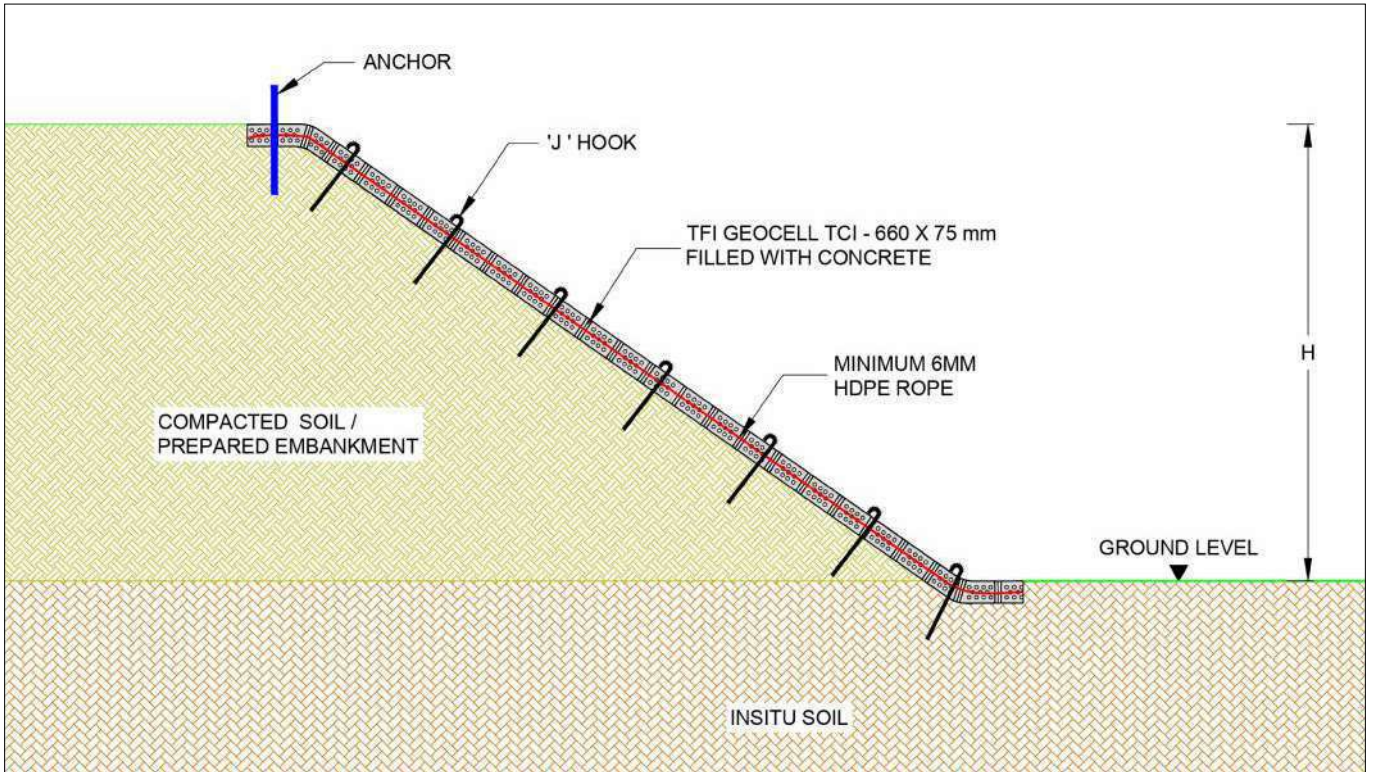

Typical Cross Section drawing



Progress of Concrete filling in Geocell



Progress of Concrete filling in Geocell



Finished surface of road embankment

Conclusion:

The Project is completed successfully and serving its purpose. The client was very happy and satisfied with product quality of TechFab India Industries Ltd.

For further details kindly contact :

TechFab India Industries Ltd.

711/712, Embassy Centre, Nariman Point, Mumbai – 400021
Tel: + 91- 22 - 2287 6224 / 6225 Fax: + 91- 22 - 2287 6218
E: info@techfabindia.com
W: www.techfabindia.com

CASE HISTORY

Rev:00, Date : 14.09.2020

EMBANKMENT PROTECTION WITH GEOCELL FOR THARAD - DHANERA - PANTHWADA SECTION OF NH-168, GUJARAT GUJARAT, INDIA



Slope Protection works

Client:	Products used:
ROADS & BUILDING DEPARTMENT, NATIONAL HIGHWAY DIVISION, GOVT. OF GUJARAT	TFI GEOCELL TCI - 660 X 75mm
Main contractor:	Quantity Supplied:
MKC INFRASTRUCTURE LTD., ANJAR - KUTCH, GUJARAT	36000 SQM
Manufacturer & Supplier:	Year of construction:
TECHFAB (INDIA) INDUSTRIES LTD.	2020

Problem:

During 2017 flood, major damage was caused in many parts of Gujarat including Dhanera and Tharad. Since last few years, average rainfall in this areas is increased which created need for special design considerations for new roads such as better drained roads, erosion protection for slope embankments, scour protection for bridge abutments and piers. So that, Road and bridges will stand strong even during worst flood situations.

This project site is located in the north part of Gujarat where weather is generally dry but sometimes heavy rains. Project scope included embankment slope where height varies from 3m to 6m. The slope of embankment (1:1.5) is prepared with locally available soil. Where embankment heights are more, 1m to 3m RCC toe wall is provided to flatten the slope. Since, soil is silty sand so the chances of vegetation growth were very less. This soil found is easily prone to erosion resulting in rain cuts and gully formation and may result into slope failure.

It was required to provide efficient erosion control system for embankment slope for this project. Project scope included embankment slopes at multiple locations.



Installation of Geocell

Solution:

Before choosing perfect erosion control system, Road & building officials decided to construct trail stretch with vetiver grass, coir mat, Palin cement concrete lining and Geocell with GSB, Geocell with soil.

Proposed cross section of geocell with GSB is attached below

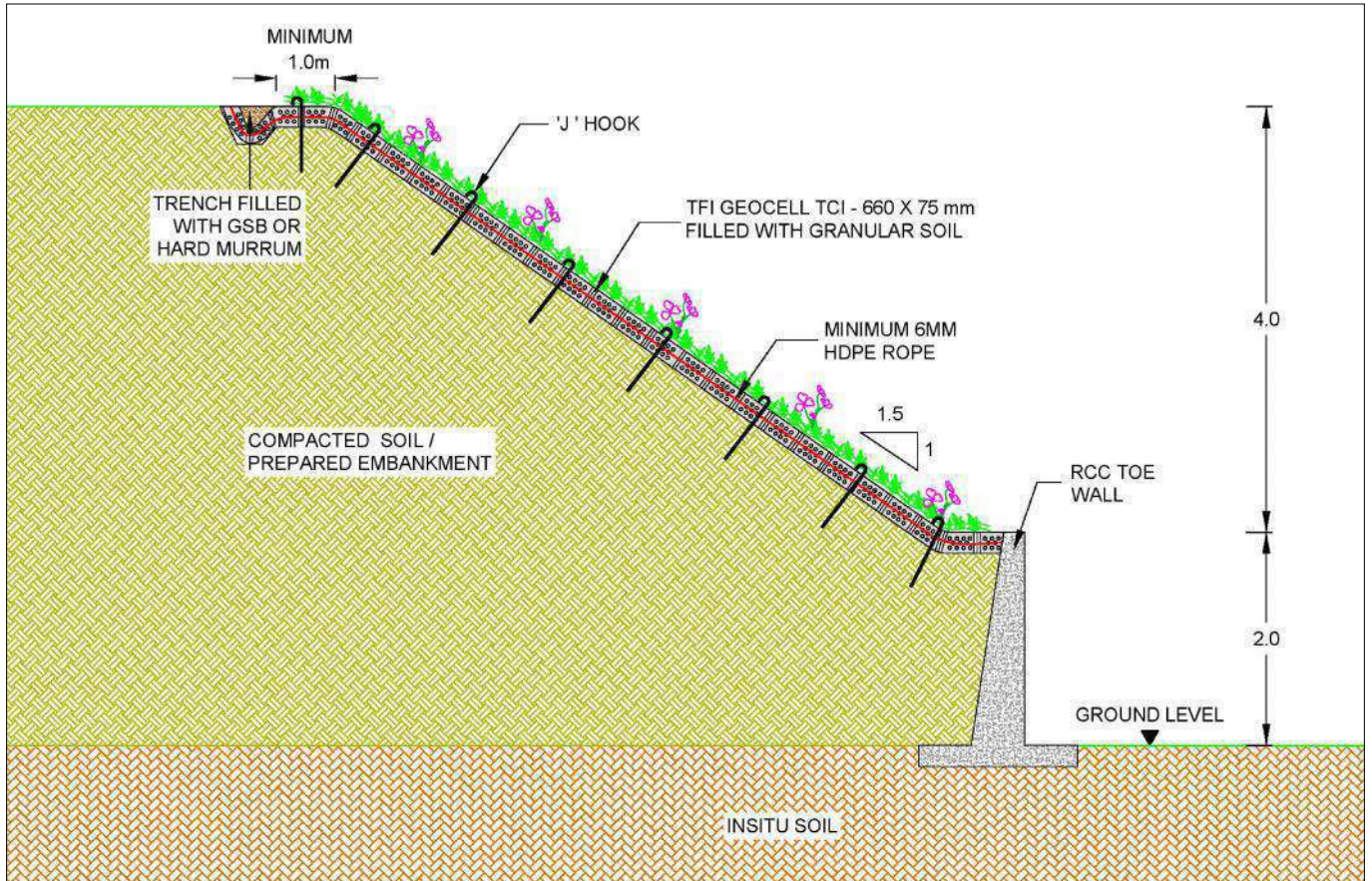

Typical Cross Section Drawing



During Construction Photographs

Few observations of all the erosion control system

- Slope top soil was covered with vegetative soil then coir mat or vettiver grass was laid to grow vegetation in dry weather condition but it requires regular watering till grass grows and need periodic maintenance. It was observed that vegetation growth was poor.
- Concrete lining provided was around 150mm which is kind of costly option for this project. Due to dry weather, small cracks were developed which could result in damaged linings. It was observed that it is time consuming and costly option.
- Geocell is three dimensional confinement system, easy to install in very short time once the slope is prepared. The filling of GSB or Granular soil not require further compaction once filled properly.
- Geocell with soil was again not recommended option as vegetation growth was poor.
- Geocell with GSB was chosen as Geocell confines infill GSB material and protects slope erosion.
- Geocell has perforated soil wall and Geocell with GSB will reduces hydraulic energy and directs flow through geocell.
- A layer of nonwoven geotextile will avoid further penetration of water in to the embankment and help drain out water efficiently .

After installation and inspection by senior officer's of Roads and Building Department, it was decided to use Geocell with GSB over other erosion protection systems and Geocell with GSB was adopted for major part of project scope.



Installation of Geocell

Execution on site :

- Prepare slope surface as per drawings. Remove debris, rocks, unacceptable soil from area where Techcell is to be laid.
- Replace removed soil with acceptable soil and compact earthwork.
- Excavate anchoring trench and toe trench according to provided design.
- Lay a layer of nonwoven if specified in the design with recommended overlap in the geotextile.
- Install J shaped anchors along anchor trench with proper alignment to hold Techcell section in place on the slope.
- Expand down the Techcell section on the slope and allow settling then fix end Techcells by using J shaped anchors.
- Adjacent Techcell must be levelled with each other and tie with each other using cable string.
- Install J hooks at specified distance as mentioned in design and drawing.
- When Techcell has been laid in place properly, Techcell should be filled with specified material.
- To prevent possible damage, limit drop height of infill to not more than 1m.
- Infill should be delivered either to top of slope or bottom of slope using a loader.
- For vegetative slope, locally available vegetative soil should be utilized as infill. Vegetation grows naturally or can be implanted as required



Installation of Nonwoven Geotextile & Geocell completed



Slope is ready and filled with GSB

For further details kindly contact :

TechFab India Industries Ltd.

711/712, Embassy Centre, Nariman Point, Mumbai – 400021

Tel: + 91- 22 - 2287 6224 / 6225 Fax: + 91- 22 - 2287 6218

E: info@techfabindia.com

W: www.techfabindia.com

CASE HISTORY

Rev:00, Date : 30.11.2020

EROSION PROTECTION WORKS AT ESR INDUSTRIAL & LOGISTIC PARK, CHAKAN, PUNE, MAHARASHTRA

PUNE, MAHARASHTRA, INDIA



Erosion Protection

Client:	Products used:
INDOSPACE INDUSTRIAL	TECHGRID TGU 40
Main Contractor:	Quantity supplied:
GEOSTAB SOLUTION	3500 SQM
Manufacturer & Supplier:	Year of construction:
TECHFAB (INDIA) INDUSTRIES LTD.	AUGUST 2020

Project description:

ESR industrial park is strategically located in MIDC Chakan, a notified Industrial Zone near Pune, surrounded by all major cities. With GFA 118,831(m²), Park has amenities like common parking, roads, storm water drains, rain water harvesting, main receiving electrical substation and sewage treatment plant.

Industrial park has road on all sides of the plot for better access for logistic point of view. Since Industrial park plot located above ground level, plot had natural surrounding slope. There was a need to create an artificial slope to protect office building, precious machinery etc.. Construction of this Industrial park was completed in April 2019 but the slopes constructed on surrounding area was kept unprotected.

During first monsoon, it was observed that the slope was eroded and rills formation took place. It is very important to protect the slope as there is Road over it. As severe Erosion due to heavy rain may result of slope and road failure.

As the height of the slope was very high i.e. 23m and length to be protected was around 350m, it was very much essential to provide sustainable, easy to construct and cost effective solution for slope erosion protection.



View of ESR industrial park

Solution:

Conventional solution for erosion control includes Stone pitching, concrete lining, vegetation etc., Stone pitching and CC Lining are the costliest and time consuming options. Only vegetation is also not feasible solution for higher heights and steep slope also it requires regular maintenance. Using geosynthetics for preventing soil erosion is proven to be cost effective option when compared with these conventional solutions.

Vegetation along with geogrid is a better method for enhancing slope stability and erosion control where unreliable vegetation growth with 100 percent coverage is extremely difficult. So, it is suggested by Consultant to construct slope (1H : 1.67 V) and which shall be covered with geogrid and vetiver grass. As the slope height is more and slope angle needs to be maintain , it is decided to construct Gabion Toe Wall at Toe of the slope.

How the Geogrids helps :

Geogrid stabilize the soil surface, and keep the seeds and vegetative soil in place, even at steep slope the soils will remain at its place, resulting in the successful germination of seeds help the penetration of water into the soil and retain moisture, ensuring the rooting and good growth of grass. Use of polymer geogrid mesh provides a long term protection as it is not biodegradable like jute or coir mat. (As Per IRC 59 2019- section 4.8.5.3) Because of longer life and almost unfailing success rate for vegetation growth rate per year , Polymer geogrid mesh is very favourable over other reinforcing concepts by using natural fibres.(As Per IRC 59 2019- section 4.8.5.3).



During Construction

Here Vetiver grass is suggested for plantation because here the growth of grass is ensure in limited time and roots grows almost straight down with few lateral surface roots, thus not interfering with the growth of other crops which could result in loss of yield. Vetiver grass can reach 3-4 m in the first year of planting. The Vetiver System, protect slopes, stop or significantly reduce the risk of slippage, and prevent down stream water contamination.



During Construction Photographs

Installation of Geogrid for Slope Erosion Protection

- The Gabion Toe Wall was constructed first as per the design.
- The soil is backfilled and slope was prepared as per the design.
- The prepared slope is Compacted layer by layer and top 30 cm vegetative soil with suitable fertilizer were loosely compacted so the vegetation/ vettiver grass can easily grow.
- The anchoring trench were prepared at the top of slope to anchor the Techgrid Geogrid as per the design.
- The Techgrid Geogrid was installed from top with anchoring the Grid in Anchor trench and the geogrid roll was unrolled down the slope in machine direction and than the Geogrid is fixed with staples and pins.
- The geogrid had full contact with soil and was anchored using staples or stakes
- Edges of parallel roll were overlapped by approximately 100mm and anchored at 800mm spacing down the slope.

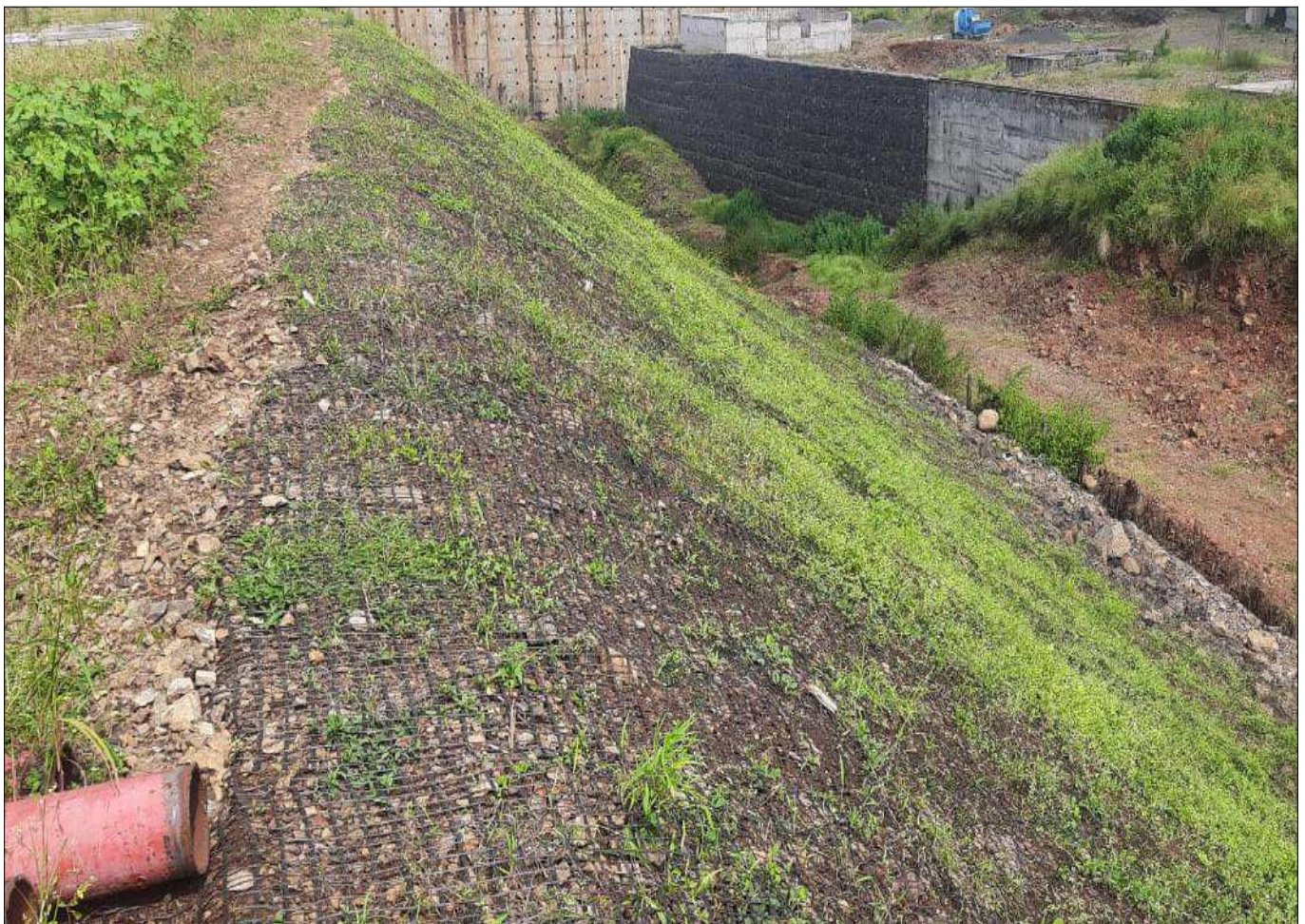

Slope after installation of Geogrid



Slope after vegetation has grown

Conclusion:

The erosion protection work with TechGrid Geogrid completed as per the clients requirement and Client is happy with the solution suggested, quality of Geogrids and timely supply of the materials.

For further details kindly contact :

TechFab India Industries Ltd.

711/712, Embassy Centre, Nariman Point, Mumbai – 400021

Tel: + 91– 22 - 2287 6224 / 6225 Fax: + 91– 22 - 2287 6218

E: info@techfabindia.com

W: www.techfabindia.com

CASE HISTORY

Rev:02, Date : 04.05.2022

REINFORCED SOIL SLOPE AT SHILLONG BYPASS CONNECTING NH-40 TO NH-44, MEGHALAYA

SHILLONG, MEGHALAYA, INDIA



Reinforced Soil Slope

Client:	Products used:
NATIONAL HIGHWAYS AUTHORITY OF INDIA (NHAI)	• TECHGRID – GEOGRID (KNITTED & PVC COATED POLYESTER GEOGRID) • TECHGEO NONWOVEN GEOTEXTILE • GEOTEXTILE BAGS • TECHFAB METAL GABIONS
Main Contractor:	
G R INFRAPROJECTS LTD.	
Design:	
BEST GEOTECHNICS PVT. LTD.	
Manufacturer & Supplier:	Year of construction:
TECHFAB (INDIA) INDUSTRIES LTD.	2014

Project description:

There is a construction of a Reinforced Soil Slope at Shillong bypass (Meghalaya) connecting NH-40 and NH-44 with the application of geosynthetics in that region which has natural mountain terrain, deep valley at rare end side, with touch of natural green aesthetic and state of the art design & architecture.

The reinforced soil slope & gabion retaining wall at toe has been proposed to slope elevated terrain in concurrence to design, consultant & architect. Their joint views have taken into many revisions before arriving at practicable solution which encircles the aesthetic view with as a final outcome at rare deep valley portion, based on the submission of M/s Best Geotechnics.

Keeping the above perspective, the scope work of TechFab India Industries Ltd., was to meet:

- Design
- Supply of Techgrid Geogrids, Metal Gabion, Nonwoven Geo textile.
- Supervision.



Reinforced Soil Slope – Top View

Salient features:

- Soil Reinforcement: Techgrid Geogrid (Knitted & PVC coated Polyester Geogrid).
- Facing: Wrap-around Geogrid facing for Reinforced Soil Slope, with Geotextile bags filled with sand. TechFab Metal Gabion as toe wall.
- Design Methodology : Ressa software for analysis.
- TechFab India Scope: * Design
* Supply of TechGrid Geogrid, Metal Gabion, Nonwoven Geotextile
* Supervision

Method statement:

- Installation of gabions, geogrids cannot be initiated until excavation; foundation preparation and levelling of soil have been completed, and properly inspected by the site engineer.
- In case of unsatisfactory preparation of sub grade by the installer, it must be rectified as guided by the Site Engineer.

Excavation:

- Excavate the sub grade vertically to the plan elevation & horizontally to the extent of the geogrid lengths.
- Remove & replace the unnecessary soil not meeting the requirement given by the design engineer with the approved materials from owner's side.
- Protect excavated materials that can be used as a backfill for the reinforcement zone against weather.



TechFab Metal Gabion Wall Layout – Initial Stage



RSS with TechGrid GeoGrid – Under Construction



Pre Final Stage of Construction

Foundation Preparation:

- Over- excavated area the sub grade shall be in maximum loose lifts of 250mm & shall be compacted to a minimum of 95% Standard Proctor Dry Density with 1% to 2% of OMC in accordance with relevant standard.
- Engineer In Charge inspect for the sub grade soil properties for the reinforced zone should fulfill the requirements according to design & drawings.

Construction:

- Construct reinforced soil slope in accordance with the approved design & drawings.
- All precautions are to be taken while placing the geogrids to avoid damages.
- Reinforced soil & backfill must fulfill the requirements according to the approved design & drawings

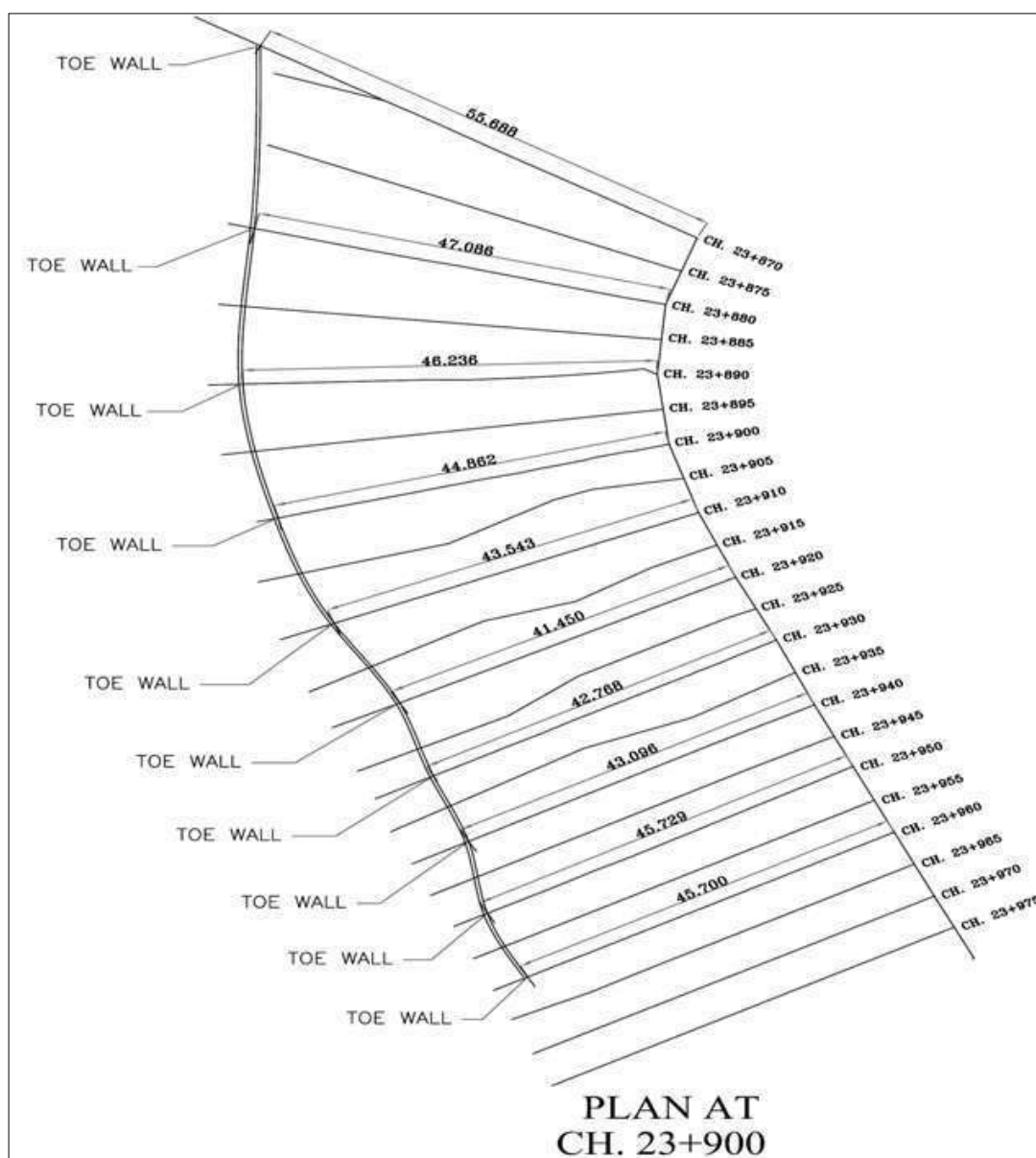

Plan

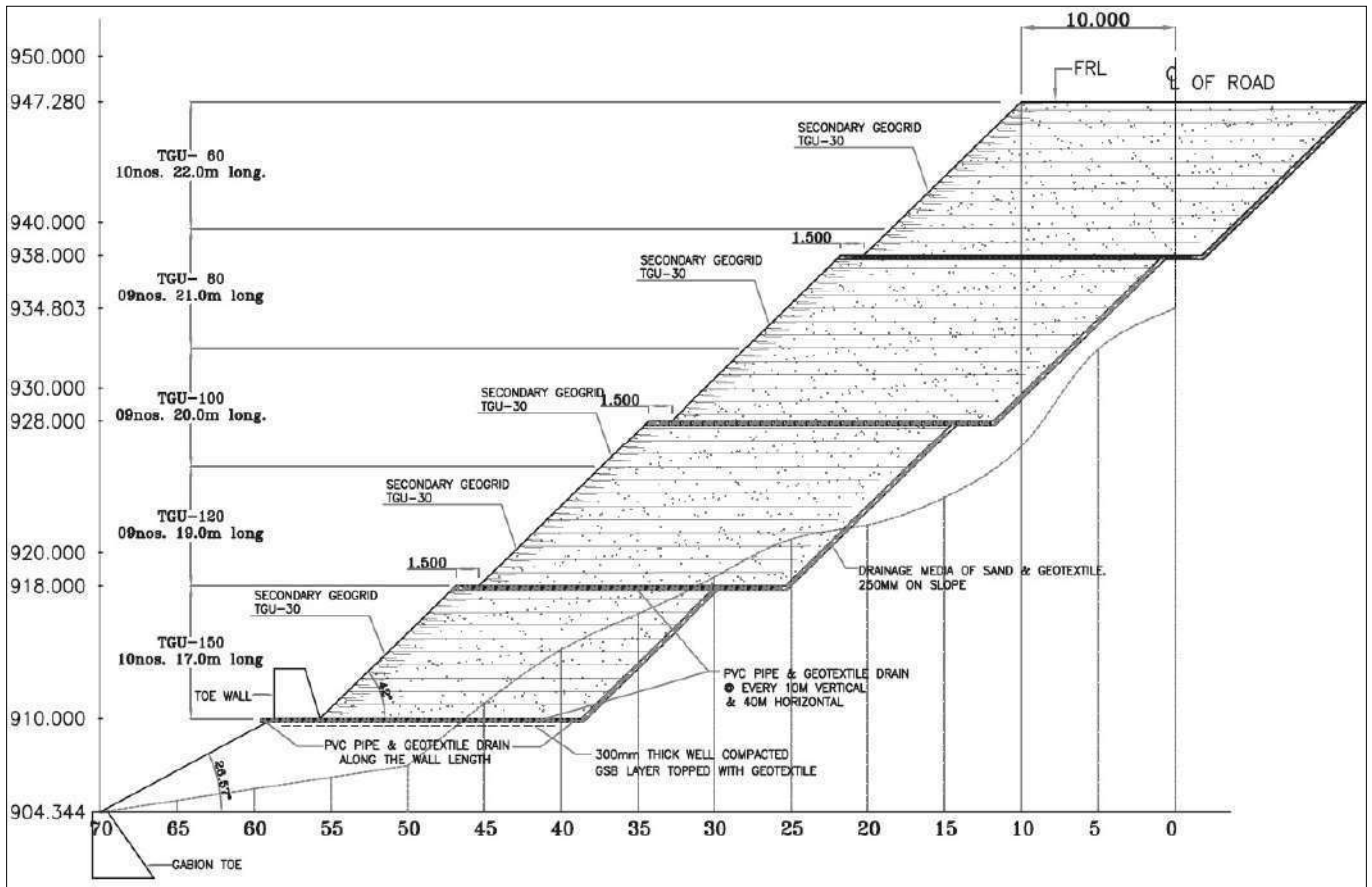

Reinforced Soil Slope – Typical Cross-section

 DEPARTMENT OF CIVIL ENGINEERING
Indian Institute of Technology Madras
Chennai 600036
Phone: (044) 2257 4263/4250
FAX: (044) 2257 4252

Dr. K. Rajagopal
Professor
June 22, 2012

To
Shri AKS Chauhan
Shillong Expressway Limited
502 DC Marak
Lower Moti Nagar
Near Fire Brigade
Shillong 793 014

Dear Shri Chauhan,

Subject: proof checking of reinforced soil slope on the Shillong bypass under construction connecting NH40 and NH 44
Reference: your letter No. GRIL/12-13/Civil/68, dt. 29-5-2012

Thank you for forwarding the design report of the above reinforced soil slope and the associated soil test reports.

I have gone through the design calculations and the different parameters assumed in the design.

Necessary clarifications and the modifications were done by your designer Mr. Satish Naik.

Based on independent calculations and the feasibility of the recommended construction procedures, I am pleased to approve the designs. Please find attached herewith the proof checking report on the designs.

Please contact the undersigned for any further clarifications.

Yours sincerely,
K. Rajagopal
K. Rajagopal 22/6/2012

Dr. K. RAJAGOPAL
Professor
Department of Civil Engineering
Indian Institute of Technology Madras
CHENNAI, TN-600 036.

 DEPARTMENT OF CIVIL ENGINEERING
Indian Institute of Technology Madras
Chennai 600036
Phone: (044) 2257 4263/4250
FAX: (044) 2257 4252

Dr. K. Rajagopal
Professor
June 22, 2012

Proof Checking of Reinforced Soil Slope on the Shillong bypass Under Construction Connecting NH40 and NH 44

Through a letter No. GRIL/12-13/Civil/68, dt. 29-5-2012, M/s GR Infraprojects Ltd. have requested IIT Madras to proof check the designs for the reinforced soil embankment being constructed at Shillong bypass road connecting NH40 and NH 44.

The complete design report, drawings and the soil investigation reports were supplied to the consultant. The designs were performed by M/s Best Geotechnics Pvt. Ltd, Mumbai. All the original design calculations were performed using the AASHTO/FHWA approved software ReSSA developed by M/s ADAMA Engineering Inc., USA.

The height of the embankments range from 28.5 m to 43 m and the slope angle as high as 50°. The reinforced soil slope design considered reinforcement layers at vertical spacing of 800 mm and secondary reinforcement layers at 400 mm vertical spacing. The soil slope is proposed to be given a wrap around slope with sand filled bag facing. The proposal is quite innovative and environmentally sustainable.

The soil properties assumed for design are reasonable and consistent with the soil test reports pertaining to the site.

The polyester knitted geogrids have very good creep resistance and will be able to provide the necessary resistance for the service life of the structure. The different reduction factors used for obtaining the long term allowable design strength are reasonable. The geogrid-soil interaction parameter of 0.80 is reasonable and slightly on the conservative side based on the data from several laboratory and field pullout tests.

The uniform surcharge pressure considered in design of 24 kPa is as per the IRC load standards for national highways.

The seismic factor assumed for design is consistent with the provisions given in IS 1893-2002 for Shillong area. The different factors assumed for estimating the peak ground acceleration like the importance factor, spectral acceleration coefficient, etc. are reasonable and consistent with the nature of the soil embankments.

The factors of safety obtained for different embankments are more than 1.30. As the earthquake seismic forces are considered, this factor of safety is reasonable. The forces developed in the reinforcement layers are within the long term allowable design strength and the factor of safety against pullout failure is more than 1.50 for all the layers.

K. Rajagopal
Dr. K. RAJAGOPAL
Professor
Department of Civil Engineering
Indian Institute of Technology Madras
CHENNAI, TN-600 036.

Design Checked by IIT (Madras) Prof. K. Rajagopal

It is noticed that pore water pressures are not considered in the stability analysis of the slopes. Hence, it is very important that the drainage layer be constructed at the back of the reinforced soil fill and the PVC drain pipes be placed with proper alignment to drain any internal water out of the soil slope.

Recommendations

- The designs proposed for the construction are found to be as per the relevant standards and the factors of safety obtained are adequate. Hence the designs are approved.
- The drainage layer should be constructed strictly as per the construction drawings using aggregate of appropriate grading and layer thickness.
- The PVC drain pipes should be placed as per the construction drawings with proper alignment and gradient for free flow of water. In any case, water should not be allowed to be stagnated within the slope body as it is detrimental for the safety of the embankment.
- The backfill should be compacted to at least 90% maximum modified Proctor density. Adequate quality control tests should be performed on each layer of compaction.
- The soil should not be placed and compacted during rainy periods. The constructed soil should be covered with polythene sheets during rainy periods to prevent soil erosion.
- The surface of the embankment is proposed to be finished by wrap around of the geogrid layers. The surface of the slope should be covered with a natural geotextile (coir or jute) in order to promote quick growth of vegetation. Once the vegetation grows, the slope surface will be safe against water or wind erosion.

K. Rajagopal
22/6/2022

Dr. K. RAJAGOPAL
Professor
Department of Civil Engineering
Indian Institute of Technology Madras
CHENNAI, TN-600 036



G R INFRAPROJECTS LIMITED
(Formerly known as G. R. Agarwal Builders and Developers Limited)
CIN : L46201GJ1995PLC098652

TO WHOM IT MAY CONCERN

Date: 20.04.2022

National Highways Authority of India (NHA) has awarded the project of Shillong Bypass (NH-40 to NH-44) to the Concessionaire M/s Shillong Expressway Ltd., as one of the lead member of Consortium M/s G R Infra project Limited has completed the project much before the scheduled completion date.

Shillong Bypass is passing through hilly terrain, there were various requirements like steep embankments, reinforced soil retaining walls & slope protection work. State-of-the-art technical solutions were adopted using advanced and latest technical methods such as mechanically stabilized soil slopes with the various grades of Techfab geogrid upto a maximum height of 45 Mtrs.

It is hereby certified that subject order was split between M/s Techfab India and M/s Best Geotechnics Pvt. Ltd. for Design, supply & supervision, and the agencies carried out their respective job to our best satisfaction.

FOR G R INFRAPROJECTS LIMITED

K. Rajagopal
AUTHORISED SIGNATORY

<p>CORPORATE OFFICE : 2nd Floor, Nexus Tower Plot No. 13, Sector-15 Gurgaon, Haryana-122015, India Ph.: +91-124-6435000</p>	<p>HEAD OFFICE : GR House, Hiran Magri, Sector-11 Udaipur, Rajasthan-313002, India Ph.: +91-294-2467370, 2483033</p>	<p>REGISTERED OFFICE : Revenue Block No. 223 Old Survey No. 384/1, 384/2, Paik and 384/3, Khata No. 464, Kochariya, Ahmedabad, Gujarat-382220, India</p>	
--	---	---	--

Email : info@grinfra.com | Website : www.grinfra.com

Design Checked by IIT (Madras) Prof. K. Rajagopal

Letter from G R Infraprojects Ltd. to TechFab India

The supplied materials, Techgrid - Geogrid, Nonwoven Geotextile, and PVC coated galvanized Gabion are the in house manufactured products of Techfab India Ltd., in their state of the ISO 9001:2008 certified factory under the proven and tested qualified experienced faculties having edge of national globally accredited QTP & QTC.



RSS with TechGrid GeoGrid – Under Construction



After Completion of Project with vegetation

For further details kindly contact :

TechFab India Industries Ltd.

711/712, Embassy Centre, Nariman Point, Mumbai – 400021

Tel: + 91- 22 - 2287 6224 / 6225 Fax: + 91- 22 - 2287 6218

E: info@techfabindia.com

W: www.techfabindia.com

CASE HISTORY

Rev:01, Date : 01.09.2020

CONSTRUCTION OF REINFORCED SOIL WALL WITH WRAP AROUND AND VEGETATED FACIA NEAR TUNNEL NO:1 AT KATRA, JAMMU & KASHMIR KATRA, JAMMU & KASHMIR, INDIA



RS Wall with Wrap around & Vegetated facia

Client:	Products used:
NORTHERN RAILWAYS	•TECHGRID KNITTED & PVC COATED POLYESTER GEOGRID WITH TENSILE STRENGTH OF 40 TO 250KN/m
Main contractor:	
KONKAN RAILWAY CORPORATION LTD / PROGRESSIVE CONSTRUCTION LTD.	Proof Check:
Manufacturer & Supplier:	INDIAN INSTITUTE OF TECHNOLOGY, DELHI
TECHFAB (INDIA) INDUSTRIES LTD.	Year of construction:
	JULY 2008

Project description:

Indian Railways had taken up the arduous task of linking the Kashmir Valley with Jammu by a rail network of 343 km. The work on first phase (56 km) between Jammu to Udhampur was completed in 2005 and services are operational on this route. The link 25 Km between Udhampur to Katra Vaishnodevi is under construction and may be completed by 2007. The work on 119 km track from Qazigund to Baramulla is nearing completion. The 138 km stretch between Katra to Qazigund was commenced in 2003. However this stretch is one of the most difficult and un-parallel to any rail linking project built in India so far. It involves 104 km of tunneling wherein one tunnel is about 10.9 km long under a rock cover of 2000 m below the Pirpanjal range of Himalayas.

This herculean task of 138 km has been entrusted to two public sector companies, from Katra to Laole between Km 30 to Km 120 to Konkan Railway Corporation Ltd (KRCL) and from Laole to Qazigund between Km 120 to 168 to IRCON International.

In Konkan Railway section, to execute entire 90 km track, construction of 225 km access road is necessary which has become a bottleneck to complete this project on time. Roads are to be built first and the railway tunnels later. The sector has a complicated topography consisting of deep gorges & heavy sliding zones.



RSRW with Wire Mesh Facia At Katra (J&K)

Salient Features of the Reinforced Soil Walls :

- Wall Facing Area: 1080 Sqm.
- Wall Height: 10 m
- Soil Reinforcement: TechGrid knitted & PVC coated polyester Geogrids with Tensile Strength of 40 to 250 KN/m
- Facing: Geogrid wrapped face supported by galvanized welded wire mesh panels with random rubble packing
- Design Methodology: BS 8006 (Static) FHWA-NHI-00-043 (Seismic)
- TFIL's scope of work: Detailed Engineering designs & drawings, supply of Geogrids, Welded wire mesh Panels & Supervision of construction
- Proof checking: Designs and drawings were proof-checked by IIT Delhi



RSRW with Wire Mesh Facia At Katra (J&K)

The Challenge:

The entire Railway Track meanders through young Himalayan Mountains which consist of sinking / slide zones. One such tough zone has been noticed at Tunnel No 1 at Katra (J&K) where the portal got buried under the slush & muck during the construction of the tunnel. This tunnel was being constructed by M/s Progressive Construction Ltd.

Following the slide the work was suspended for sometime, further discussion and proposals were undertaken with various consultants and agencies to avoid such unfortunate incidents in future.

Finally, the existing muck was cleared and a false tunnel 30 m length was constructed from the face of the tunnel. The Portal of the Tunnel consists of more than 100 m high slide zone, which is very vulnerable to land slide and washing away of the foundation soil from the both side of the portal, it was proposed to have Reinforced Soil Walls on both the sides of the tunnel.

Solution:

M/s Progressive Construction Ltd (PCL) contacted TechFab India Industries Ltd for providing the techno-commercial offer for the protection of tunnel against the landslide occurring in the highly seismic prone zone.

After a careful evaluation of the project requirements and site conditions a geogrid reinforced soil wall with a welded wire mesh supported wrapped face was finalized as the most optimum solution.

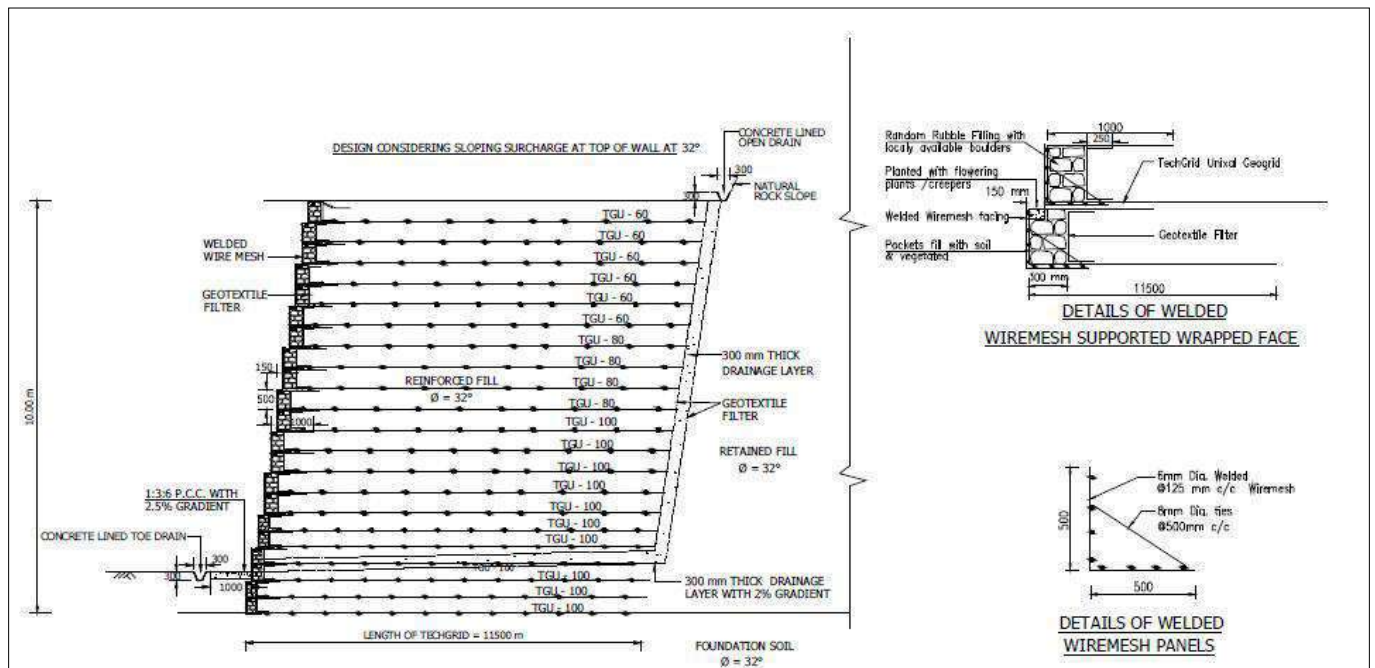

Typical Cross section drawing

TechGrid knitted and PVC coated polyester geogrids, manufactured by TechFab India at their state of the art ISO 9001: 2000 certified plant in Silvassa, were used as the soil reinforcement. TechGrid geogrids are manufactured from select grades of high tenacity, high molecular weight polyester yarns using an advanced weft insertion warp knitting process and coated with a specially formulated PVC plastic. The high performance characteristics of these world class geogrids enabled the walls as high as 10 m, to be designed safely and economically.

The facing comprised a geogrid wrapped face supported by L shaped galvanized welded wire mesh panels with galvanized steel ties at 500 mm spacing. Ability to accommodate appreciable amounts of differential settlements

was one of the major reasons for adopting this type of facing. After completion of the project the facia was vegetated, to give it additional stability against the erosion.

The proposed Reinforced Soil Wall would act as impact resistance pad on both sides of the tunnel taking the load of the slush/ muck which may come over the tunnel with high momentum endangering the foundation if the portal.



RSRW with Wire Mesh Facia At Katra (J&K)

The design of the walls was carried out using the BS 8006 (static) FHWA-NHI-00-043(seismic) guidelines and comprised checks for external, internal and global stability under static and seismic conditions. The design calculations and construction drawings were proof-checked by Indian Institute of Technology Delhi.

Construction of the wall was carried out under the supervision of TechFab India Industries Ltd.



RSRW with Wire Mesh Facia At Katra (J&K)

Conclusion:

The project was successfully completed in July 2008.

For further details kindly contact :

TechFab India Industries Ltd.

711/712, Embassy Centre, Nariman Point, Mumbai – 400021
Tel: + 91- 22 - 2287 6224 / 6225 Fax: + 91- 22 - 2287 6218
E: info@techfabindia.com
W: www.techfabindia.com

CASE HISTORY

Rev:01, Date : 01.06.2020

REINFORCED SOIL WALL WITH WELDED WIRE MESH FACING TO RETAIN THE APPROACHES TO A FLYOVER AT DND - MAYUR VIHAR LINK ROAD PHASE I & II, NEW DELHI NEW DELHI, INDIA



RS Wall with Welded wire mesh facia

Client: NOIDA TOLL BRIDGE COMPANY LTD. (NTBCL)	Products used: • TECHGRID KNITTED & PVC COATED POLYESTER GEOGRID WITH TENSILE STRENGTH OF 40 TO 200KN/m • NONWOVEN GEOTEXTILE
Main contractor: K R ANAND, DELHI	
Manufacturer & Supplier: TECHFAB (INDIA) INDUSTRIES LTD.	Year of construction: DECEMBER 2007

Project description:

The Noida Toll Bridge Company Ltd. (NTBCL) has been promoted by Infrastructure Leasing and Financial Services Ltd. (IL&FS) as a special purpose vehicle to develop, construct, operate and maintain the eight lane DND Flyway (including a bridge across the Yamuna river) connecting South Delhi to Noida on a Build Own Operate Transfer (BOOT) basis. The company's principal source of revenue is from the levy of tolls on commuters on this facility. NTBCL constructed a DND-Mayur Vihar Link Road to attract the large population living in the Trans-Yamuna area of Mayur Vihar to use DND Flyway to increase its revenue.

This DND-Mayur Vihar Link Road required the construction of a flyover, whose approach embankments had a maximum height of 9.0 on the DND end and 14.0 m on the Mayur Vihar End. Since there was no constraint with respect to right-of-way, the approaches consisted of normal embankments. However, retaining walls were to be constructed as closure walls behind the abutment piers and 25 m long return walls at both ends of the flyover.

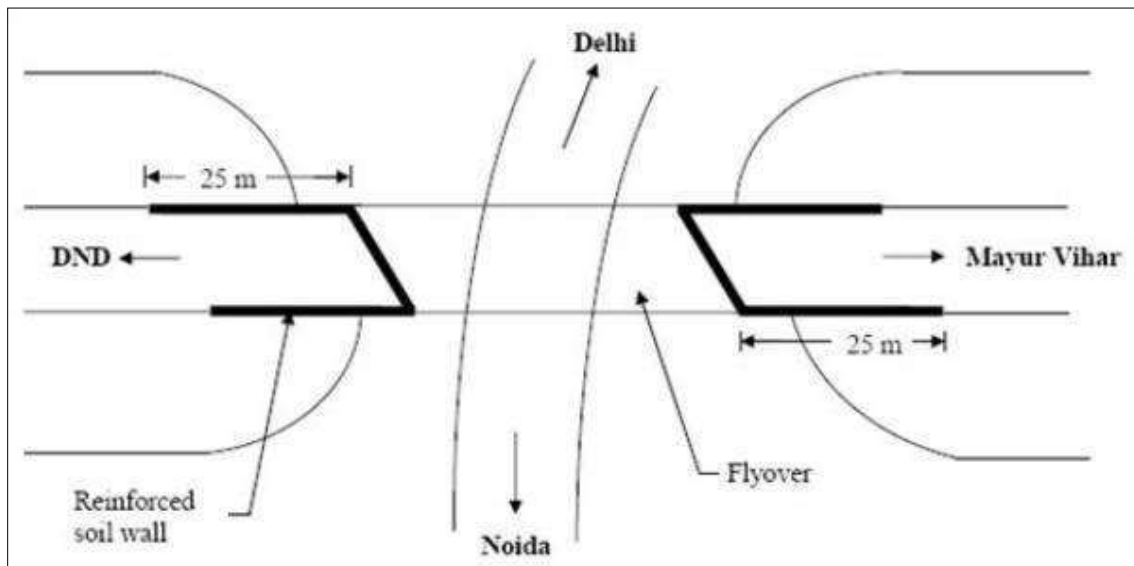

NTBCL decided to use reinforced soil technology for the construction of retaining walls in view of their proven performance and cost economy. The design of the walls involved several technical difficulties and the construction had to be completed within a short time. After a rigorous evaluation of various aspects, NTBCL accepted the geogrid reinforced soil wall with a welded wire mesh facing proposed by Techfab India as best suited to the project and site requirements and awarded the work to Techfab India with the following scope of work:

- Detailed engineering of the reinforced soil walls and ground improvement including design, material specifications, construction drawings and construction methodology.
- Supply of Techgrid geogrids, galvanized welded wire mesh panels and nonwoven geotextile
- Supervision of construction

The Challenge:

The design of the walls involved several challenges:

- The maximum height of the wall was about 15.0 m on the Mayur Vihar end of the flyover.
- Because the alignment of the flyover was in skew, the closure and return walls were not perpendicular to each other. There were acute angle corners with interior angle between closure wall and return wall of 42° on the DND end and 58° on the Mayur Vihar end. The design and detailing of the soil reinforcement for the acute angle corners, presents several difficulties.
- The facing batter of the closure walls had to be kept as low as possible, to avoid any problems with respect to the design of approach slabs.
- The upper most strata of the ground comprised a 2 to 5 mm thick layer of sandy clayey silts / sandy silts with relatively loose consistency (N = 2 - 5).

Solution:

After a careful evaluation of the project requirements and site conditions a geogrid reinforced soil wall with a welded wire mesh supported wrapped face was finalized as the most optimum solution.

Techgrid knitted and PVC coated polyester geogrids, manufactured by Techfab India at their state-of-the art ISO 9001:2000 certified plant in Silvassa, were used as the soil reinforcement. Techgrid geogrids are manufactured from select grades of high tenacity, high molecular weight polyester yarns using an advanced weft insertion warp knitting process and coated with a specially formulated PVC plastisol. The high performance characteristics of these world-class geogrids, enabled the walls as high as 15 m, to be designed safely and economically.

The facing comprised a geogrid wrapped face supported by L shaped galvanized welded wire mesh panels with galvanized steel ties at 500 mm spacing. A 350 mm thick random rubble packing was provided to enhance the rigidity of the facing and to protect the fill material. A nonwoven geotextile filter was used behind the rubble to contain the fill material, which was a fine sand. The overall inward batter of the facing was approximately 5°.



During Construction Photographs

Salient Features of the Reinforced Soil Walls :

- Wall Facing Area: 1600 Sqm.
- Wall Height: 14.0 to 15.0 m on Mayur Vihar end and 9.0 to 10.0 m on DND end.
- Soil Reinforcement: TechGrid knitted & PVC coated polyester Geogrids with Tensile Strength of 40 to 200 KN/m
- Facing: Geogrid wrapped face supported by galvanized welded wire mesh panels with random rubble backing with batter of 5°
- Fill Material: Sand from Yamuna River
- Design Methodology: FHWA-NHI-00-043
- TFIL's scope of work: Detail Engineering designs & drawings, supply of Geogrids, Welded wire mesh panels and Nonwoven Geotextile & Supervision of construction
- Proof checking: Designs and drawings were proof-checked by IIT Delhi

Ability to accommodate appreciable amounts of differential settlements was one of the major reasons for adopting this type of facing.

The fill material was a relatively fine-grained sand dredged from the Yamuna river. The design angle of shearing resistance of the compacted sand was 35°.

The ground treatment consisted of the partial excavation and removal of the upper layer of the loose sandy clayey silt / silt sand and replacement with a compacted layer of sand reinforced with Techgrid TGB-90 biaxial geogrids with a tensile strength of 90 kN/m in both machine and cross machine directions.

The design of the walls was carried out using the FHWA-NHI-00-043 guidelines and comprised checks for external, internal and global stability under static and seismic conditions. The design calculations and construction drawings were proof-checked by Indian Institute of Technology Delhi.

Construction of the wall was carried out under of Techfab India's supervision.

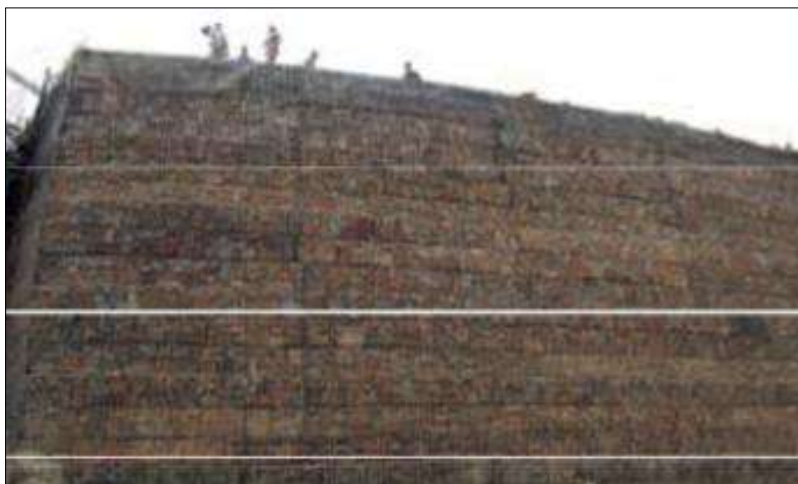

15 m high wall at Mayur Vihar End nearing completion



Conclusion:

The project was successfully completed in December 2007..

For further details kindly contact :

TechFab India Industries Ltd.

711/712, Embassy Centre, Nariman Point, Mumbai – 400021
Tel: + 91- 22 - 2287 6224 / 6225 Fax: + 91- 22 - 2287 6218
E: info@techfabindia.com
W: www.techfabindia.com

CASE HISTORY

Rev:01, Date : 20.08.2020

REINFORCED SOIL WALL WITH WELDED WIRE MESH FACING FOR CONSTRUCTION OF APPROACHES FOR COAL HANDLING AREA AND HOPPER PIT AND TUNNEL FOR THE POWER PLANT AT WARDHA, MAHARASHTRA
WARDHA, MAHARASHTRA, INDIA



RS Wall with Welded wire mesh facia

Client:	Products used:
LLOYDS STEEL INDUSTRIES LTD.	TECHGRID KNITTED & PVC COATED POLYESTER GEOGRID WITH TENSILE STRENGTH OF 40 - 200KN/M
Main contractor:	
INDRAJEET INFRASTRUCTURE LTD.	Year of construction:
Manufacturer & Supplier:	APRIL 2008
TECHFAB (INDIA) INDUSTRIES LTD.	

Project description:

M/s. Lloyds Steel Industries Ltd is constructing a captive power plant for its existing steel plant at Wardha near Nagpur. The construction involves an approach ramp to be made to the coal handling area and hopper pit and tunnel.

M/s. Lloyds steel Industries Ltd wanted a solution from Techfab India Industries Ltd. to construct the approach ramp that is fast, economical, use of local slag material as a fill for the approaches (they had the problem of dumping the slag)and the structure should be long lasting with proven performance. M/s. Lloyds Steel Industries Ltd decided to use Reinforced soil technology for the construction of retaining walls in view of their proven performance and cost economy.

The design of the walls involved several technical difficulties and the construction had to be completed within a short time. After a rigorous evaluation of various aspects, M/s. Lloyds Steel Industries Ltd. accepted the geogrid reinforced soil wall with a welded wire mesh facing proposed by Techfab India Industries Ltd. as best suited to the project and site requirements and awarded the work to Techfab India Industries Ltd with the following scope of work:

- Detailed engineering of the reinforced soil walls including design, material specifications, construction drawings and construction methodology.
- Supply of Techgrid geogrids and nonwoven geotextile
- Supervision of construction



The Reinforced Soil Wall System

The Challenge:

The design of the walls involved several challenges:

- The maximum height of the ramp was about 10.0 m .
- The fill considered in the design is a composite of good quality murrum and locally available slag material
- The loading considered is the live load of moving truck for transportation of the coal is 100 MT .
- The facing batter of the walls had to be kept as low as possible



During Construction Photograph

Solution:

After a careful evaluation of the project requirements and site conditions a geogrid reinforced soil wall with a welded wire mesh supported wrapped face was finalized as the most optimum solution. Techgrid knitted and PVC coated polyester geogrids, manufactured by Techfab India at their state-of the art ISO 9001:2000 certified plant in Silvassa, were used as the soil reinforcement. Techgrid geogrids are manufactured from select grades of high tenacity, high molecular weight polyester yarns using an advanced weft insertion warp knitting process and coated with a specially formulated PVC plastisol. The high performance characteristics of these world-class geogrids, enabled the walls as high as 15 m, to be designed safely and economically.

The facing comprised a geogrid wrapped face supported by L shaped galvanized welded wire mesh panels with galvanized steel ties at 500 mm spacing. The packing with locally available slag was provided to enhance the rigidity of the facing and to protect the fill material. A nonwoven geotextile filter was used behind the rubble to contain the fill material, which was a composite of good quality murrum and locally available slag material. The overall inward batter of the facing was approximately 5°.

Ability to accommodate appreciable amounts of differential settlements was one of the major reasons for adopting this type of facing. The design of the walls was carried out using the FHWA-NHI-00-043 guidelines and comprised checks for external, internal and global stability under static and seismic conditions. Construction of the wall was carried out under the supervision of Techfab India's supervision.

Salient Features of the Reinforced Soil Walls :

- Wall Facing Area: 800 Sqm.
- Wall Height: 10m
- Soil Reinforcement: TechGrid knitted & PVC coated polyester Geogrids with Tensile Strength of 40 to 200 KN/m
- Facing: Geogrid wrapped face supported by galvanized welded wire mesh panels filled with locally available slag with batter of 5°
- Fill Material: Composite of Local Slag material with good quality murrum
- Design Methodology: FHWA-NHI-00-043 Seismic Zone II
- TFIL's scope of work: Detailed Engineering designs & drawings, supply of Geogrids, Welded wire mesh panels and Nonwoven Geotextile & Supervision of construction



During construction photograph



Completed Structure

Conclusion:

The project was successfully completed in April 2008.

For further details kindly contact :

TechFab India Industries Ltd.

711/712, Embassy Centre, Nariman Point, Mumbai – 400021

Tel: + 91- 22 - 2287 6224 / 6225 Fax: + 91- 22 - 2287 6218

E: info@techfabindia.com

W: www.techfabindia.com

CASE HISTORY

Rev:01, Date : 04.06.2020

CONSTRUCTION OF EMBANKMENT USING TFI 5200 TAPE WOVEN GEOTEXTILE & TGU 40 TECHGRID GEOGRIDS AT IT CORRIDOR IN CHENNAI, TAMIL NADU
CHENNAI, TAMILNADU, INDIA



Embankment Stabilization

Client:	Products used & Quantity supplied:
TAMILNADU ROAD DEVELOPMENT CORPORATION (TNRDC), CHENNAI	TFI 5200 TAPE WOVEN GEOTEXTILE AND UNIAXIAL KNITTED PVC COATED POLYESTER GEOGRID TGU-40
Consultant:	
WILBER SMITH ASSOCIATES, INDIA	
Manufacturer & Supplier:	Year of construction:
TECHFAB (INDIA) INDUSTRIES LTD.	JANUARY 2007

Project brief:

As a part of improvement and widening of the IT corridor in Chennai, low embankments (Height varies from 0.75m to a maximum 1.50m) were to be constructed on ground underlain by weak soil deposits in the stretches of the Km 1/490 to 1/670 and 2/100 to 2/800. Consultant for the project Wilbur Smith Associates Pvt. Ltd. asked Techfab India Mumbai to evaluate the ground and loading conditions and suitable stabilization measures.

Problem:

In view of low shear strength and high compressibility of the poor soil strata there was concern regarding shear failure and excessive settlement.

The soil profile at the site was follows (Starting from ground level):

- Filled up ground consisting of the loose uncontrolled fill mixed with garbage with thickness of 1.50m to 1.7m.
- Black clay + Clayey sand / Silty sand with thickness of 1.30 to 1.50. The black clay is stiff clay with N values in the range 13 to 22. Silty fine sand is loose with N values of 3.
- Very soft clay with thickness of approx 5.0m. N values for this layer is typically Nil. Only in one case N value 4 is obtained. Undrained cohesion values obtained from direct shear / UCC tests are in the range of 4.0 to 5.0 kPa.



During Construction Photographs



During Construction

Solution:

Since the upper most layers consist of loose fill and soil mixed with garbage, it was decided to excavate and remove this layer completely and replaced with compacted quarry dust.

The major problems to be solved were:

- Stability of the embankment because of the very low shear strength of the very soft clay layer.
- Placement and compaction of fill (to replace the layer of filled-up ground) was very difficult because of the soft clay and high water table conditions.

After analyzing the ground conditions, Techfab India proposed the following economical solution that saved time and money both by not having to import the fill or use heavy equipment for installation. The use of woven geotextile TFI 5200 and TechGrid TGU 40 uniaxial geogrid allows the construction companies to work economically, quickly, safely:

- Where the embankment height was very low ($\leq 0.75\text{m}$) there was no problem with regard to stability. However placement and proper compaction of fill was difficult. Here it was proposed to lay a geotextile (TFI 5200 Tape Woven Geotextile) on top of the excavated surface to act as a separator cum reinforcement. Above this a 200mm thick layer of quarry dust was to be placed, spread and leveled. After this construction equipment could move on the fill and compact it. The geotextile would work as a tensioned membrane supporting the weight of construction equipment and facilitating satisfactory compaction.
- Where the embankment height was more than 0.75m, stability calculations showed that factor of safety against rotational failure was not adequate. Hence it was decided to go for basal reinforcement using Techgrid knitted and PVC coated polyester geogrids as shown in Figures. In view of the urgency of clients to complete the work, TechGrid TGU 40, a uniaxial geogrid with a tensile strength of 40 kN/m in the machine direction, which was readily available in stock was selected. Stability calculations showed that for embankment heights of 0.75m to 1.50m, one layer of TechGrid TGU 40 was adequate. For embankment heights of 1.5 to 2.0m, two layers of TechGrid TGU 40 were provided.



Laying of TechGrid TGU-40 as Basal Reinforcement



Laying down fill over TechGrid TGU-40 for Embankment



Laying down fill over TechGrid TGU-40 for Embankment

For further details kindly contact :

TechFab India Industries Ltd.

711/712, Embassy Centre, Nariman Point, Mumbai – 400021

Tel: + 91– 22 - 2287 6224 / 6225 Fax: + 91– 22 - 2287 6218

E: info@techfabindia.com

W: www.techfabindia.com

CASE HISTORY

Rev:01, Date : 04.09.2020

**CONSTRUCTION OF EMBANKMENT USING TFI 5200 TAPE WOVEN
GEOTEXTILE AT CALICUT BYPASS PHASE-III, NH-17, CALICUT, KERALA**
CALICUT, KERALA, INDIA



Embankment Stabilization

Client:	Products used & Quantity supplied:
NATIONAL HIGHWAYS AUTHORITY OF INDIA (NHAI)	POLYPROPYLENE TAPE X TAPE WOVEN GEOTEXTILE (TECHFAB TPP 250 EQUIVALENT TO TFI 5300) IN 5M WIDTH
Contractor: BHARAT GEOSYSTEMS, CHENNAI	
Manufacturer & Supplier:	Year of construction:
TECHFAB (INDIA) INDUSTRIES LTD.	OCTOBER 2003

Project brief:

As a part of the Calicut Bypass Phase III project, funded by the Ministry of Road Transport & Highways and executed by Public Works Department (National Highways), Kerala, it was required to construct a three km. long road embankment with heights up to 5m, on very soft ground comprising old paddy fields and marshy land. Techfab Woven Geotextile was used to solve difficult problems associated with construction of embankments on soft sub-grades.

Problem:

The thickness of the soft clays at the site varied from 3 m to 8 m. Hence issues of embankment stability and post-construction settlements need to be carefully considered. Also, the upper most clay layer was extremely soft with very high water content. Therefore, it was not possible to carryout normal construction operations on this stratum. However, removal of this layer was not a viable option because of uncertainty in thickness of layer, cost and time involved in excavation and removal and environmental objections to disposal of the excavated material. Hence innovative techniques were considered to find a satisfactory and cost-effective solution to these problems.



Installation of Techfab TPP 250 Woven Geotextile

The Solution:

Pre-fabricated Vertical Drains were installed to accelerate the consolidation of the soft clays. As the clay consolidated, there was a corresponding increase in the shear strength, thereby ensuring adequate stability of the embankment. It also ensured that most of the settlements occurred prior to construction of the pavement.

As an alternative to excavation and removal of the top layer of extremely soft clay, it was decided to use a woven Geotextile to stabilize the sub-grade. After a careful evaluation of the required Geotextile functions and properties, Techfab TPP 250, a woven polypropylene tape Geotextile manufactured by Techfab India was selected for this purpose. The Geotextile had a combination of mechanical and hydraulic characteristics making it suitable to function as a separator and reinforcement. In addition, it had a width of 5 m to minimize overlaps.

Techfab TPP 250 Woven Geotextile installed at the surface of the sub-grade functioned as a separator between the very soft clay and the better quality fill material allowing placement of fill material without mixing and excessive rutting. It also acted as a reinforcement supporting the loads imposed by the initial lifts of embankment fill and construction traffic without inducing shear failure of the clay foundation. The restraint offered by the Geotextile, enabled the proper compaction of the initial lifts of embankment fill.

The use of Techfab TPP 250 Woven Geotextile resulted in an environmentfriendly Solution and enabled the successful completion of the project with appreciable savings In cost and time.



Installation of Techfab TPP 250 Woven Geotextile

For further details kindly contact :

TechFab India Industries Ltd.

711/712, Embassy Centre, Nariman Point, Mumbai – 400021

Tel: + 91– 22 - 2287 6224 / 6225 Fax: + 91– 22 - 2287 6218

E: info@techfabindia.com

W: www.techfabindia.com

CASE HISTORY

Rev:01, Date : 04.09.2020

CONSTRUCTION OF EMBANKMENT USING HIGH STRENGTH POLYESTER WOVEN GEOTEXTILE TFI 3200 FOR APPROACHES OF RAJIV GANDHI SETU BRIDGE CONNECTING NANI DAMAN & MOTI DAMAN IN UT OF DAMAN GUJARAT, INDIA



Embankment Stabilization

Client:	Products used & Quantity supplied:
GOVERNMENT OF GUJARAT (ROADS & BUILDINGS DEPARTMENT)	WOVEN GEOTEXTILE TFI 3200 OF STRENGTH 200 KN/m - 82000 SQM.
Main contractor:	Consultant:
VIJAY M MISTRY CONSTRUCTION PVT LTD.	SHELADIA ASSOCIATES & CONSULTANTS PVT LTD.
Manufacturer & Supplier:	Year of construction:
TECHFAB (INDIA) INDUSTRIES LTD.	FEBRUARY 2009

Problem:

The approaches of the embankment to be constructed on soft soils having CBR value less than 2 . The maximum height of the embankment to be constructed on the soft foundation soil is 11m with a heavy traffic live load .



Existing Area Being Prepared



Laying of High Strength Geotextile TFI 3200

Solution:

The project consultant proposed 2 layers of high strength polyester woven geotextile of strength 200 KN/m in the principal direction & a granular fill of 900mm thickness at the base. The geotextile proposed acts as a basal reinforcement for the embankment and also as a separation layer to separate the granular fill of 900mm thick and the proposed fill .

Techfab India Industries Ltd herein referred as TFI supplied 82000 sqm of high strength polyester woven geotextile TFI 3200 of strength 200 KN/m in the principal direction, meeting all the technical specifications as proposed by the consultant for the project.



Murum Layer Being placed over Geotextile



Embankment work in progress & partially completed



Rajiv Gandhi Setu Bridge completed & open for Traffic

For further details kindly contact :

TechFab India Industries Ltd.

711/712, Embassy Centre, Nariman Point, Mumbai – 400021

Tel: + 91– 22 - 2287 6224 / 6225 Fax: + 91– 22 - 2287 6218

E: info@techfabindia.com

W: www.techfabindia.com

CASE HISTORY

Rev:00, Date : 10.12.2022



CONSTRUCTION OF GABION RETAINING WALL FOR SHORE PROTECTION WORKS AT NIGERIA

NIGERIA

Retention works

Client:	Products used:
RAPID LINK MULTINATIONAL LTD.	<ul style="list-style-type: none">• TECHFAB METAL GABION (ZN+PVC COATED)• TECHGEO NON WOVEN GEOTEXTILE
Main contractor:	
Manufacturer & Supplier:	Year of Construction:
TECHFAB (INDIA) INDUSTRIES LTD.	2021

Problem:

Due to wave action during rising of sea level and high rise tides, extensive erosion has been observed along the boundary of the plot near sea face. This was affecting the aesthetics and safety of the visitors around. So, it was necessary to construct a retaining structure that will retain the soil behind it in place and prevent erosion. The height of the protection was 4.0m (above ground level).

Solution:

In order to overcome the problem of erosion and retain the sea facing slope, TechFab India has proposed the construction of Gabion retaining wall, which is one of the quickest and most economical ways to reduce shoreline erosion. Gabion Retaining walls are very much suitable in case of retaining structures for protection, nearby the water body. Gabions can take differential settlement effectively. Gabion retaining walls are highly permeable, flexible and free draining and hence do not develop pore water pressure.

A Gabion wall of 5.0m height including foundation depth is constructed and geotextile is also provided as a filter media behind the retaining wall. For the scour protection, gabion mattress has been recommended.



During Construction Photograph

Benefits of TechFab Metal Gabion over Conventional RCC Retaining Wall on site:

TechFab Metal Gabion was suggested for retaining and erosion control purposes in lieu of the conventional R.C.C Retaining Wall for achieving the following advantages:

- Flexible structure which can accommodate differential settlement.
- Free draining structure with no pore pressure development behind wall.
- Easy in construction, as it does not require skilled labourers.
- Does not require curing time as in case of R.C.C Retaining wall.
- Eco-friendly, as the vegetation growth over it, is compatible with surrounding environment.
- Advanced coating of gabion makes is resistance to corrosion under areas which are in constant / partial submergence.
- Cost incurred is significantly less compared to R.C.C Retaining Wall.

Benefits of TechGeo Nonwoven Geotextile:

- Acts as a “Filter” by preventing the backfill material from being washed out through Gabion face.
- Acts as a “Separator” between the backfill material and the Gabion fascia and thereby prevents the mixing of the tow.



During Construction Photographs - Gabion filling with boulders



During Construction Photographs



Completed Structure of Gabion Wall

Present Status of the Project:

The Project is completed successfully.

For further details kindly contact :

TechFab India Industries Ltd.

711/712, Embassy Centre, Nariman Point, Mumbai – 400021
Tel: + 91- 22 - 2287 6224 / 6225 Fax: + 91- 22 - 2287 6218
E: info@techfabindia.com
W: www.techfabindia.com

CASE HISTORY

Rev:00, Date : 21.06.2022

CONSTRUCTION OF GABION RETAINING WALL FOR ALDEIA DE AT BAMBOLIM BEACH, GOA

BAMBOLIM, GOA, INDIA



Retention works

Client:	Products used:
GOAN REAL ESTATE AND CONSTRUCTION PRIVATE LTD	• TECHFAB METAL GABION • TECHGEO PR20 GEOTEXTILE
Main contractor:	
--	
Manufacturer & Supplier:	Year of Construction:
TECHFAB (INDIA) INDUSTRIES LTD.	2022

Problem:

Aldeia De Goa - A sea side Hill Station spread over 145 acres of land located at Bambolim Beach, Goa. It is the most preferred location for numerous home seekers in Goa.

Due to wave action during rising of sea level and high rise tides, extensive erosion has been observed along the boundary of Aldeia De plot near sea face. This was affecting the aesthetics and safety of the visitors around. So, it was necessary to construct a retaining structure that will retain the soil behind it in place and prevent erosion. The height of the protection was varying from 2.5m to 4.0m (above ground level). The length of the stretch to be protected was approximately 550m.

Solution:

In order to overcome the problem of erosion and retain the sea facing slope, TechFab India has proposed the construction of Gabion retaining wall, which is one of the quickest and most economical ways to reduce shoreline erosion. Gabion Retaining walls are very much suitable in case of retaining structures for protection, nearby the water body. Gabions can take differential settlement effectively. Gabion retaining walls are highly permeable, flexible and free draining and hence do not develop pore water pressure. Since the structure is vulnerable to saline water, advanced coating like 90%Zinc+10%Al+PVC coating was recommended for gabion wire mesh.

A Gabion wall of 3.5m to 5.0m height including foundation depth is constructed and geotextile is also provided as a filter media behind the retaining wall. For the scour protection, a combination of gabion mattress and boulder pitching has been recommended.



View of Aldeia De Goa

Benefits of TechFab Metal Gabion over Conventional RCC Retaining Wall on site:

TechFab Metal Gabion was suggested for retaining and erosion control purposes in lieu of the conventional R.C.C Retaining Wall for achieving the following advantages:

- Flexible structure which can accommodate differential settlement.
- Free draining structure with no pore pressure development behind wall.
- Easy in construction, as it does not require skilled labourers.
- Does not require curing time as in case of R.C.C Retaining wall.
- Eco-friendly, as the vegetation growth over it, is compatible with surrounding environment.
- Advanced coating of gabion makes is resistance to corrosion under areas which are in constant / partial submergence.
- Cost incurred is significantly less compared to R.C.C Retaining Wall.
- Most importantly, the fill material of gabion (except front 0.5m facing) was locally available lateritic boulders.

Benefits of TechGeo Nonwoven Geotextile:

- Acts as a “Filter” by preventing the backfill material from being washed out through Gabion face.
- Acts as a “Separator” between the backfill material and the Gabion fascia and thereby prevents the mixing of the tow.

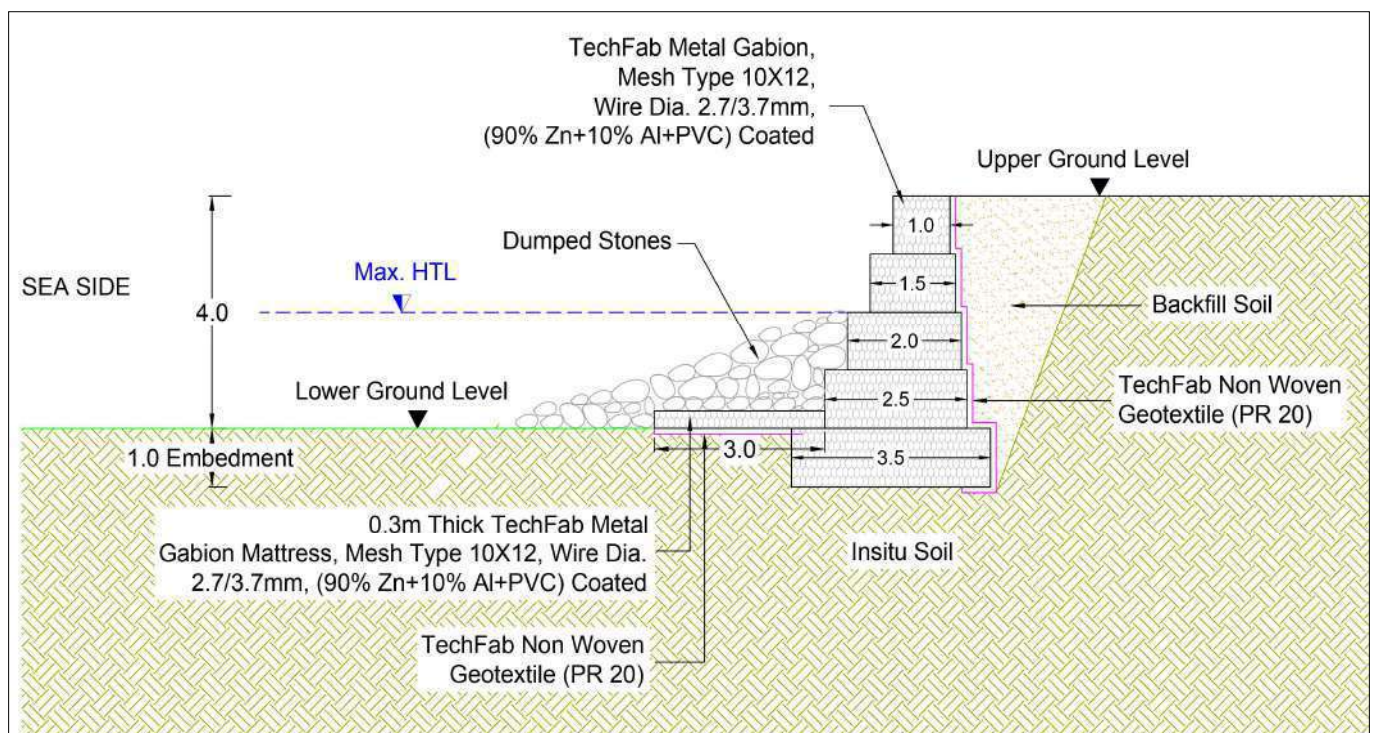

Typical Cross Section of 5.0m High Gabion Retaining Wall



During Construction Photographs. Back side filling of units done with locally available lateritic boulders



Completed Structure of Gabion Wall

Conclusion:

The Project is completed successfully. Use of locally available lateritic boulders for gabion fill and toe pitching attracted the client most as this saved significant cost and saved construction time.

For further details kindly contact :

TechFab India Industries Ltd.

711/712, Embassy Centre, Nariman Point, Mumbai – 400021

Tel: + 91- 22 - 2287 6224 / 6225 Fax: + 91- 22 - 2287 6218

E: info@techfabindia.com

W: www.techfabindia.com

CASE HISTORY

Rev:01, Date : 08.09.2020



CONSTRUCTION OF GABION RETAINING WALL & GUTTER FOR HIGH VELOCITY WATER-WAY AT MANDHARDEVI, SATARA, MAHARASHTRA

SATARA, MAHARASHTRA, INDIA

Retention Works

Client:	Products used:
MAHARASHTRA TOURISM DEVELOPMENT CORPORATION, MUMBAI (MTDC)	TECHFAB METAL GABIONS ZINC + PVC COATED TECHGEO NONWOVEN GEOTEXTILE PR 20
Main contractor:	Quantity supplied:
MIRACLE ENGINEERING & INFRA, PUNE	
Manufacturer & Supplier:	Year of construction:
TECHFAB (INDIA) INDUSTRIES LTD.	

Approach Length: 570m

Approach Height: 2.0m to 4.0m

Problem & Challenge:

“Mandhardevi” temple is 400yrs old and situated at 4,650 feet above the sea level, 20Km from Satara. The temple is located in the vicinity of nature, which makes it a popular tourist spot and is well known among Hindus who celebrate Kalubai Jatra in the month of January every year which lasts 10days. Every year approximately 2, 00,000 Hindu devotees visit the place. But unfortunately on 25th January 2005, 300 peoples were died because of stampede and fire at Mandhardevi temple in Maharashtra. To avoid such incident in future, to reduce the crowd, MTDC made decision to construct a shopping complex outside temple area, but the complex area was surrounded by small hills of very loose type of soil (murum) therefore protection is to be needed against landslides before construction.

Techfab (India) Industries Ltd submitted a proposal with solution of Gabion Retaining wall on three sides of shopping complex as a retaining structure and to prevent erosion. Also the Gabion wall was planned in such way that it will provide drainage to rain water, coming from hilly terrain. By providing such dual function wall, it protects the human life and their properties at low line area. The submitted proposal compared with the conventional solution of rigid retaining wall and proved to be an economical solution. So Executive Engineer, MTDC, Mumbai approved the proposal during meeting & discussion.



TechFab Metal Gabion - Installation

The Solution:

Gabion Retaining walls are flexible structures which are very suitable in case of retaining structures for protection, nearby the water body. Gabions can take settlement which may occur in such regions. Walls of varying height (2.0m to 4.0m), was proposed. TechGeo Nonwoven Geotextile PR 20 was placed at the rear end of gabion wall which acts as filter.

Gabion construction is fast and can be done using unskilled labors. Boulders are available in the vicinity, reduced the overall project cost and make the project very cost effective. Excavation for minimum 1 meter depth was carried out in the virgin soil. Any unsuitable soil removed and replaced with good quality soil. Nonwoven Geotextile are used beneath and behind the Gabion wall for filtration purpose. Compacted filling was proposed and being carried out at site. Final batter as per the design was achieved after the completion of the work.



TechFab Metal Gabion

Benefits of TechFab Metal Gabion over Conventional RCC Retaining Wall:

TechFab Metal Gabion was suggested for retaining and erosion control purposes in lieu of the conventional R.C.C Retaining Wall for achieving the following advantages:

- Flexible structure which can accommodate differential settlement.
- Free draining structure with no pore pressure development behind wall.
- Easy in construction, as it does not require skilled labourers.
- Does not require curing time as in case of R.C.C Retaining wall.
- Eco-friendly, as the vegetation growth over it, is compatible with surrounding environment.
- Does not corrode under areas which are in constant / partial submergence.
- Cost incurred is very less compared to R.C.C Retaining Wall and depends only on the local availability of boulders.

Benefits of TechGeo Nonwoven Geotextile:

- Acts as a “Filter” by preventing the backfill material from being washed out through Gabion face.
- Acts as a “Separator” between the backfill material and the Gabion facia and thereby prevents the mixing of the tow.



TechFab Metal Gabion - Longitudinal View

Conclusion:

TechFab Metal Gabion and TechGeo Nonwoven Geotextile satisfied all the technical parameters for their effective usage. The execution was successfully completed in time. The department was satisfied with the material quality and in time execution of project.

For further details kindly contact :

TechFab India Industries Ltd.

711/712, Embassy Centre, Nariman Point, Mumbai – 400021

Tel: + 91– 22 - 2287 6224 / 6225 Fax: + 91– 22 - 2287 6218

E: info@techfabindia.com

W: www.techfabindia.com

CASE HISTORY

Rev:01, Date : 14.05.2020

CONSTRUCTION OF PIPE CULVERT BY USING TECHFAB METAL GABIONS AT GHANA, SOUTH AFRICA

GHANA, SOUTH AFRICA



Hydraulic Works

Client:	Products used & Quantity supplied:
	<ul style="list-style-type: none">• TECHFAB METAL GABIONS ZINC+PVC COATED• NONWOVEN GEOTEXTILE
Main contractor:	
Manufacturer & Supplier:	Year of construction:
TECHFAB (INDIA) INDUSTRIES LTD.	SEPTEMBER 2019

Project description:

In October 2018, under government program of development of Ghana infrastructure, it was decided to build this Pipe culvert so that it will ease up to commute between two villages.

Project challenges:

During monsoon, it was observed very high velocity flow in the river with 1m – 2m of water level in the River throughout the season and the access between two village was completely closed during this period, the Authority has earlier decided to construct the bridge which seems to be uneconomical at this location., Finally it was decided to construct the pipe culvert structure. The concrete pipe culvert again has some draw back during submerge condition so it was decided to construct flexible Gabion Pipe Structure in such condition.

Solution:

The proposed solution here is with the RCC Pipes and Flexible Techfab Metal Gabions and Gabion Mattresses as apron.

The gabion structures become a flexible, permeable and monolithic structure and cost effective compare to the reinforced cement concrete structures. In this type hydraulic application and especially in transverse structure, the flexibility of structure play very important role., which can be constructed easily with very low foundation depth, if require can be constructed underwater up to certain depth, and gabion structure will take care of unequal settlement may occur.

So, Authority has decided to construct Gabion Pipe Culvert with flexible Gabion mattress as scour apron.

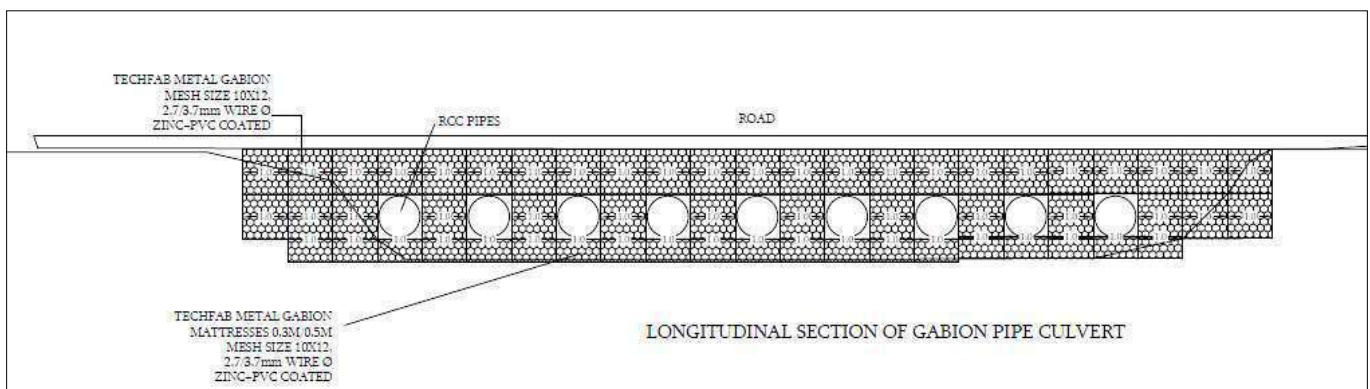

Typical Longitudinal Section of Gabion pipe culvert

Execution on Site:

- The ground surface over which the gabions are to be laid was inspected for any irregularities or weak pockets. In case any irregularities or weak pockets are observed, they were rectified by removing the weak soil and replacing by good granular material.
- For the purpose of easy transportation and handling during transportation, the Gabions are bundled and packed in a flat folded manner. Each box should be carefully opened out, laid flat and straightened out so that all the kinks and creases are removed. The sides and the diaphragm are then lifted vertical and laced together to form a box like structure.

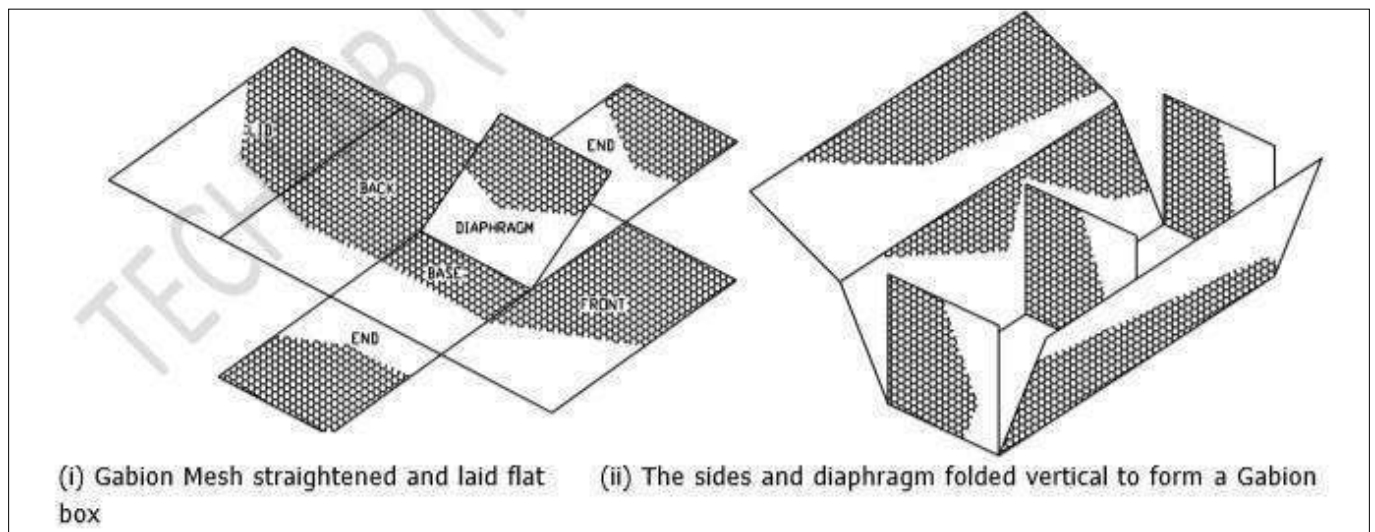

- The sides and the diaphragms were laced together using the lacing wire provided with Gabions / Mattress having the same quality of mesh wire, to form a gabion box.
- The selvedge wire along each edge was laced to the adjacent selvedge wire to give a continuous joint.
- Every box was laced to adjacent box and box below or above it, so that the whole structure is interconnected.
- Gabion was filled by using well graded stone fill and by hand packing of the stone fill.



During Construction



Completed Structure

Conclusion:

The Gabion pipe culvert is constructed successfully in September 2019 and the traffic has start moving. The Authority is very happy with the speed of construction and the working of structure as it is fulfilling the purpose for which it is constructed in well manner.

For further details kindly contact :

TechFab India Industries Ltd.

711/712, Embassy Centre, Nariman Point, Mumbai – 400021

Tel: + 91– 22 - 2287 6224 / 6225 Fax: + 91– 22 - 2287 6218

E: info@techfabindia.com

W: www.techfabindia.com

CASE HISTORY

Rev:01, Date : 14.08.2020



CONSTRUCTION OF GABION RETAINING WALL AT BEAWAR PALI, RAJASTHAN

BEAWAR PALI, RAJASTHAN, INDIA

TECHFAB INDIA

Retention Works

Client:	Products used:
NATIONAL HIGHWAYS AUTHORITY OF INDIA (NHAI)	TECHFAB METAL GABIONS ZINC+PVC COATED
Main contractor:	TECHGEO NONWOVEN GEOTEXTILE PR20
L&T ECC	Quantity supplied:
Manufacturer & Supplier:	Year of construction:
TECHFAB (INDIA) INDUSTRIES LTD.	

Project brief:

L&T ECC was executing the project of four laning, starts from Pali village of Rajasthan. Regions are hilly with rocky terrain. Road alignment was passing through higher elevation. There is a need for retaining structures of varying height to support the elevated road. Road was also passing through the tunnel, where heavy blasting was carried out. Due to blasting, boulders are available and can be used for retaining structures.

Solution:

Considering the requirement and resources available, we have proposed Gabion Gravity structures for various heights. It has been decided to consider up to maximum 10 meter of height for single wall. For the height, more than 10 meters, two tiered wall of Gabion wall with minimum berm width of 1.0 meter was proposed.

Gabion Retaining walls are flexible structures which are very suitable in case of retaining structures for protection. It is also very effective for the protection near the water body, as the porosity of boulders will dissipate the wave energy effectively. Gabions are flexible in nature and can accommodate differential settlement very well. In future, with due design consideration height of wall may be increased, if required. Gabion Walls of varying height (0.5m to 14.0m), were designed and executed. There is a requirement of filter behind the Gabion wall, to avoid erosion of backfill material. TechGeo Nonwoven Geotextile PR 20 was placed at the rear end of gabion wall which acts as filter.

Gabion construction is fast and can be done using unskilled labours. Boulders are available in the vicinity, reduced the overall project cost and make the project very cost effective. Excavation for minimum 1 meter depth was carried out in the virgin soil. Any unsuitable soil removed and replaced with good quality soil. Nonwoven Geotextile are used beneath and behind the Gabion wall for filtration purpose. Compacted filling was proposed and being carried out at site. Final batter as per the design was achieved after the completion of the work.



TechFab Metal Gabion - Initial Stage



TechFab Metal Gabion Wall

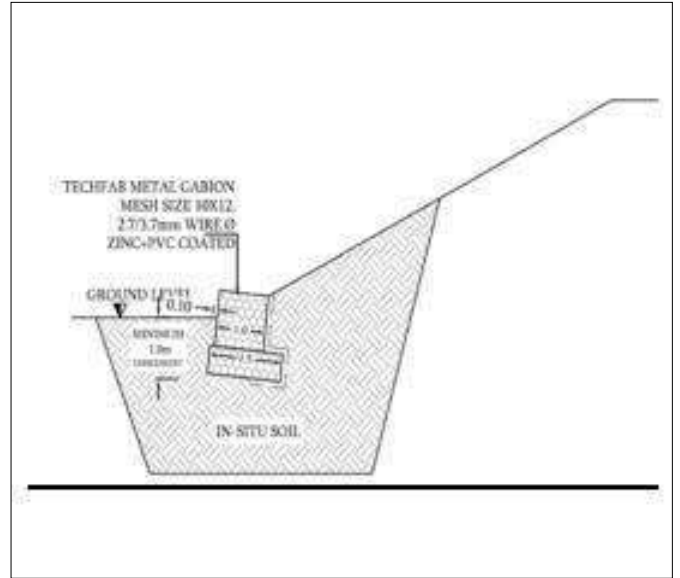
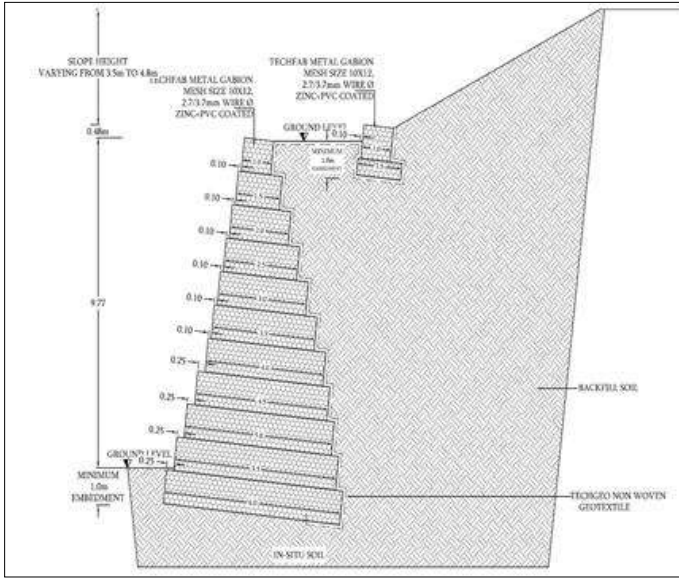

Typical Cross Section Drawings



Construction Stage - I



Construction Stage - II



Two Tier Wall – Longitudinal View



TechFab Metal Gabion



Two Tier Wall Alignments



TechFab Metal Gabion – Top View

Benefits of TechFab Metal Gabion over Conventional RCC Retaining Wall:

TechFab Metal Gabion was suggested for retaining and erosion control purposes in lieu of the conventional R.C.C Retaining Wall for achieving the following advantages:

- Flexible structure which can accommodate differential settlement.
- Free draining structure with no pore pressure development behind wall.
- Easy in construction, as it does not require skilled labourers.
- Does not require curing time as in case of R.C.C Retaining wall.
- Eco-friendly, as the vegetation growth over it, is compatible with surrounding environment.
- Does not corrode under areas which are in constant / partial submergence.
- Cost incurred is very less compared to R.C.C Retaining Wall and depends only on the local availability of boulders.

Benefits of TechGeo Nonwoven Geotextile:

- Acts as a “Filter” by preventing the backfill material from being washed out through Gabion face.
- Acts as a “Separator” between the backfill material and the Gabion facia and thereby prevents the mixing of the tow.



TechFab Metal Gabion – Front View

Conclusion:

TechFab Metal Gabion and TechGeo Nonwoven Geotextile satisfied all the technical parameters for their effective usage. The execution was successfully completed in time. The department was satisfied with the material quality and on time execution of project.

For further details kindly contact :

TechFab India Industries Ltd.

711/712, Embassy Centre, Nariman Point, Mumbai – 400021

Tel: + 91– 22 - 2287 6224 / 6225 Fax: + 91– 22 - 2287 6218

E: info@techfabindia.com

W: www.techfabindia.com

CASE HISTORY

Rev:01, Date : 14.08.2020

CONSTRUCTION OF GABION RETAINING WALL TO SH-130 PACHGAON TO KANDALGAON ROAD ODR-90 AT KM. 0/000 - 4/300 KARVEER, KOLHAPUR KOLHAPUR, MAHARASHTRA, INDIA



Retention Works

Client:	Products used:
MAHARASHTRA RURAL ROAD DEVELOPMENT ASSOCIATION / PMGSY / NRRDA	TECHFAB METAL GABIONS ZINC+PVC COATED TECHGEO NONWOVEN GEOTEXTILE PR20 (200 GSM)
Main contractor:	Quantity supplied:
TRIVENI CONSTRUCTION, KOLHAPUR	
Manufacturer & Supplier:	Year of construction:
TECHFAB (INDIA) INDUSTRIES LTD.	

Approach Length : 96m

Approach Height : 2.5m to 4.5m

Solution:

Gabion Retaining walls are flexible structures which are very suitable in case of retaining structures for protection, nearby the water body. Gabions can take settlement which may occur in such regions. Walls of varying height (1m to 4.5m), was proposed. TechGeo Nonwoven Geotextile PR 20 was placed at the rear end of gabion wall which acts as filter.

Gabion construction is fast and can be done using unskilled labours. Boulders are available in the vicinity, reduced the overall project cost and make the project very cost effective. Excavation for minimum 1 meter depth was carried out in the virgin soil. Any unsuitable soil removed and replaced with good quality soil. Nonwoven Geotextile are used beneath and behind the Gabion wall for filtration purpose. Compacted filling was proposed and being carried out at site. Final batter as per the design was achieved after the completion of the work.



TechFab Metal Gabion



TechFab Metal Gabion Installation Photographs

Benefits of TechFab Metal Gabion over Conventional RCC Retaining Wall:

TechFab Metal Gabion was suggested for retaining and erosion control purposes in lieu of the conventional R.C.C Retaining Wall for achieving the following advantages:

- Flexible structure which can accommodate differential settlement.
- Free draining structure with no pore pressure development behind wall.
- Easy in construction, as it does not require skilled labourers.
- Does not require curing time as in case of R.C.C Retaining wall.
- Eco-friendly, as the vegetation growth over it, is compatible with surrounding environment.
- Does not corrode under areas which are in constant / partial submergence.
- Cost incurred is very less compared to R.C.C Retaining Wall and depends only on the local availability of boulders.

Benefits of TechGeo Nonwoven Geotextile:

- Acts as a “Filter” by preventing the backfill material from being washed out through Gabion face.
- Acts as a “Separator” between the backfill material and the Gabion facia and thereby prevents the mixing of the tow.



TechFab Metal Gabion – Longitudinal View

Conclusion:

TechFab Metal Gabion and TechGeo Nonwoven Geotextile satisfied all the technical parameters for their effective usage. The execution was successfully completed in time. The department was satisfied with the material quality and in time execution of project.

For further details kindly contact :

TechFab India Industries Ltd.

711/712, Embassy Centre, Nariman Point, Mumbai – 400021

Tel: + 91– 22 - 2287 6224 / 6225 Fax: + 91– 22 - 2287 6218

E: info@techfabindia.com

W: www.techfabindia.com

CASE HISTORY

Rev:01, Date : 24.08.2020

EARTH RETENTION & PROTECTION WORKS AT FOUR LANING OF HAZARIBAGH - RANCHI SECTION OF NH-33, JHARKHAND UNDER NHDP PHASE - III

JHARKHAND, INDIA

Retention Works

Client:	Products used:
NATIONAL HIGHWAYS AUTHORITY OF INDIA (NHAI)	TECHFAB METAL GABIONS ZINC COATED
Main contractor:	TECHGEO NONWOVEN GEOTEXTILE PR20 (200GSM)
HAZARIBAGH RANCHI EXPRESSWAY LTD (JV COMPANY OF ITNL AND PUNJLLOYD)	Quantity supplied:
	GABIONS - 15,000 CUM, TECHGEO - 10,000 SQM
Manufacturer & Supplier:	Year of construction:
TECHFAB (INDIA) INDUSTRIES LTD.	2011

Problem & Challenge:

“Ghanti” is around 10Km length of hill stretch along Ranchi – Hazaribagh road section of NH-33. Due to steep hill section and numbers of hair pin bends, traffic movement on this stretch of road had been very slow and even well below the NHAI guideline of maximum speed for traffic movement of 40Km/hr. With an objective to speed up the traffic movement and faster accessibility, NHAI undertook plan to re-align this road stretch to make the road more or less straight and with smooth curve portion. Additionally, for further safety of vehicle and stability of hill side road embankment, extensive protection work was considered using Steel Gabion technology in valley side.

Thereby, TechFab (India) Industries Ltd suggested TechFab Metal Gabion and TechGeo Nonwoven Geotextile to serve the required purpose. The project was awarded to Hazaribagh Ranchi Expressway Ltd (JV Company of ITNL and Punj Lloyd) which in turn had subcontracted the work to GR Infraprojects Ltd (GRIL). GR Infraprojects Ltd (GRIL) awarded the supply and execution of Metal Gabion and Nonwoven Geotextile to M/s TechFab India Infrastructure LLP (a subsidiary of TechFab India Industries Ltd, formed to provide end-to-end design and build solutions in the field of Infrastructure enhanced with Geosynthetics).

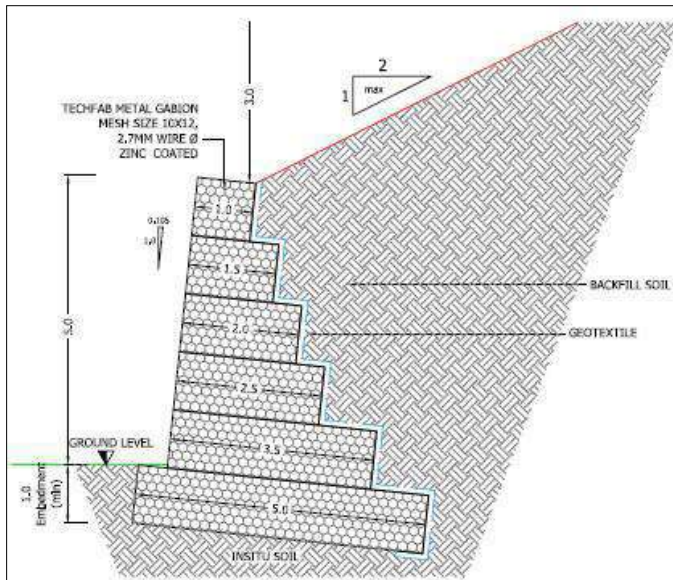

Photo 1 & 2 : TechFab Metal Gabion Installation in progress

Solution:

Gabion Retaining walls are flexible structures which are very suitable in case of retaining structures in deep valley. Gabions can take settlement which may occur in such regions. Walls of varying height (1m to 6m) with surcharge slope of 1V:2H was proposed. TechGeo Nonwoven Geotextile PR 20 was placed at the rear end of gabion wall which acts as filter.

Gabion construction is fast and can be done using unskilled labours hence the project was completed in time. TechFab Metal Gabion and TechGeo Nonwoven Geotextile satisfied all the technical parameters for their effective usage. Thereby, TechFab India Infrastructure LLP successfully supplied and executed 15,000 Cum of TechFab Metal Gabion and 10,000 Sqm of TechGeo Nonwoven Geotextile PR 20 (200 Gsm).



Cross section of 5.0m High Metal Gabion Wall



Photo 3: TechFab Metal Gabion Wall - Side View

Benefits of TechFab Metal Gabion over Conventional RCC Retaining Wall:

TechFab Metal Gabion was suggested for retaining and erosion control purposes in lieu of the conventional R.C.C Retaining Wall for achieving the following advantages:

- Flexible structure which can accommodate differential settlement.
- Free draining structure with no pore pressure development behind wall.
- Easy in construction, as it does not require skilled labourers.
- Does not require curing time as in case of R.C.C Retaining wall.
- Eco-friendly, as the vegetation growth over it, is compatible with surrounding environment.
- Does not corrode under areas which are in constant / partial submergence.
- Cost incurred is very less compared to R.C.C Retaining Wall and depends only on the local availability of boulders.

Benefits of TechGeo Nonwoven Geotextile:

- Acts as a "Filter" by preventing the backfill material from being washed out through Gabion face.
- Acts as a "Separator" between the backfill material and the Gabion facia and thereby prevents the mixing of the tow.



Photo 4 : Completed Structure - Top View



Completion Certificate : Supply and Execution of TechFab Metal Gabion and TechGeo Nonwoven Geotextile

Conclusion:

The execution was successfully completed in time. The department was happy with the material quality and in time execution of project.

For further details kindly contact :

TechFab India Industries Ltd.

711/712, Embassy Centre, Nariman Point, Mumbai – 400021

Tel: + 91– 22 - 2287 6224 / 6225 Fax: + 91– 22 - 2287 6218

E: info@techfabindia.com

W: www.techfabindia.com

CASE HISTORY

Rev:01, Date : 13.05.2020

BANK PROTECTION AND FLOOD CONTROL MEASURES FOR MADHUMATI AND BONAR NALLAH AT BANDIPORA, SRINAGAR

BANDIPORA, SRINAGAR, INDIA



Flood Protection Works

Client:	Products used:
	TECHFAB METAL GABIONS ZINC+PVC COATED
Main contractor:	Quantity supplied:
	173171 CUM
Manufacturer & Supplier:	Year of construction:
TECHFAB (INDIA) INDUSTRIES LTD.	2015

Problem:

In 2015, both Nallah had experienced severe bank erosion due to melting of ice at high altitude and release of water from the Kishan Ganga Hydro Electric Power Project (KGHEP) which caused flood in nearby villages as well as high erosion of the river.



Photo 1: Gabion Installation in progress

Project Challenges:

This region is surrounded by high slope mountain and due to steep gradient; the velocity of water is quite high causing erosion of the bank and bed of the channel. It is observed that there is erosion at various locations along the nallah thus posing threat to the community staying along the banks.

Solution:

The advantage of Gabion wall & other form of energy conservative structures was adopted for its easy construction; economy & flexibility. The gabion structures go easy with surrounding & maintain ecological balance by allowing growth of flora and fauna of the regime.

The permeable nature of the Metal Gabion eliminates buildup of hydrostatic pressure behind the retaining structure and uplifts caused by turbulent flows.

The flexibility of the double twisted hexagonal mesh helps in withstanding differential settlement without fracturing the structure particularly when a structure is installed on unstable and uneven ground or in an area where scours from waves or current can undermine.

Metal Gabion structures are heavy monolithic gravity units able to withstand earth's thrust. Its efficiency increases instead of decreasing with age since further consolidation takes place as silt and soil collect on the voids and vegetation establishes itself.

Execution on site:

The work was extremely challenging in terms taking material to site due to steep gradient, high water level & surrounded by locality. The temporary access road was constructed & water from nallah was diverted to facilitate gabion work. The gabions were placed in situ by varying foundation depth 1m to 3m. We have given extensive training for proper implementation of gabion at site. The contractor started the work simultaneously at various locations due to its urgency and timeline fixed in the contract. The series of gabion retaining wall: spur & energy dissipater were being constructed along Bonar & Madhumati Nallah.



Photo 2: During Construction



Photo 3: Completed Structure

Conclusion:

The gabion wall work completed satisfactorily. The social benefits of the gabion wall are erosion control of the bank and protection from Flood of surrounding community as well as local crews can be easily trained on site to perform the installation job which results into improved social economic value of the region.

For further details kindly contact :

TechFab India Industries Ltd.

711/712, Embassy Centre, Nariman Point, Mumbai – 400021

Tel: + 91– 22 - 2287 6224 / 6225 Fax: + 91– 22 - 2287 6218

E: info@techfabindia.com

W: www.techfabindia.com

CASE HISTORY

Rev:01, Date : 14.05.2020

CONSTRUCTION OF GABION RETAINING WALL FOR RAJKAMAL SITE AT JUHU BEACH, MUMBAI

MUMBAI, MAHARASHTRA, INDIA



Retaining Structures

Client:	Products used:
M/S. DYNAMIC GROUP	TECHFAB METAL GABIONS ZINC+PVC COATED TECHGEO NONWOVEN GEOTEXTILE PR20 (200GSM)
Main contractor:	Quantity supplied:
Manufacturer & Supplier:	Year of construction:
TECHFAB (INDIA) INDUSTRIES LTD.	

Solution:

Gabion Retaining walls are flexible structures which are very suitable in case of retaining structures for protection, nearby the water body. Gabions can take differential settlement effectively.

Gabions are very effective for the protection work near by the water body, such as river bank or sea shore. Nonwoven Geotextile are used beneath and behind the Gabion wall for filtration purpose. Client is intended to reclaim the land such that the same can be utilized for gardening in the location of Juhu beach, Mumbai. Gabion retaining wall was the ideal choice for earth retention at sea shore for gardening & other recreational purpose. After completion of Gabion wall installation, area is very pleasant in look with architectural aspects.



Photo 1 : TechFab Metal Gabion - Longitudinal view

Benefits of TechGeo Nonwoven Geotextile:

- Acts as a “Filter” by preventing the backfill material from being washed out through Gabion face.
- Acts as a “Separator” between the backfill material and the Gabion facia and thereby prevents the mixing of the tow.

Benefits of TechFab Metal Gabion over Conventional RCC Retaining Wall on site:

TechFab Metal Gabion was suggested for retaining and erosion control purposes in lieu of the conventional R.C.C Retaining Wall for achieving the following advantages:

- Flexible structure which can accommodate differential settlement.
- Free draining structure with no pore pressure development behind wall.
- Easy in construction, as it does not require skilled labourers.
- Does not require curing time as in case of R.C.C Retaining wall.
- Eco-friendly, as the vegetation growth over it, is compatible with surrounding environment.
- Does not corrode under areas which are in constant / partial submergence.
- Cost incurred is very less compared to R.C.C Retaining Wall and depends only on the local availability of boulders.

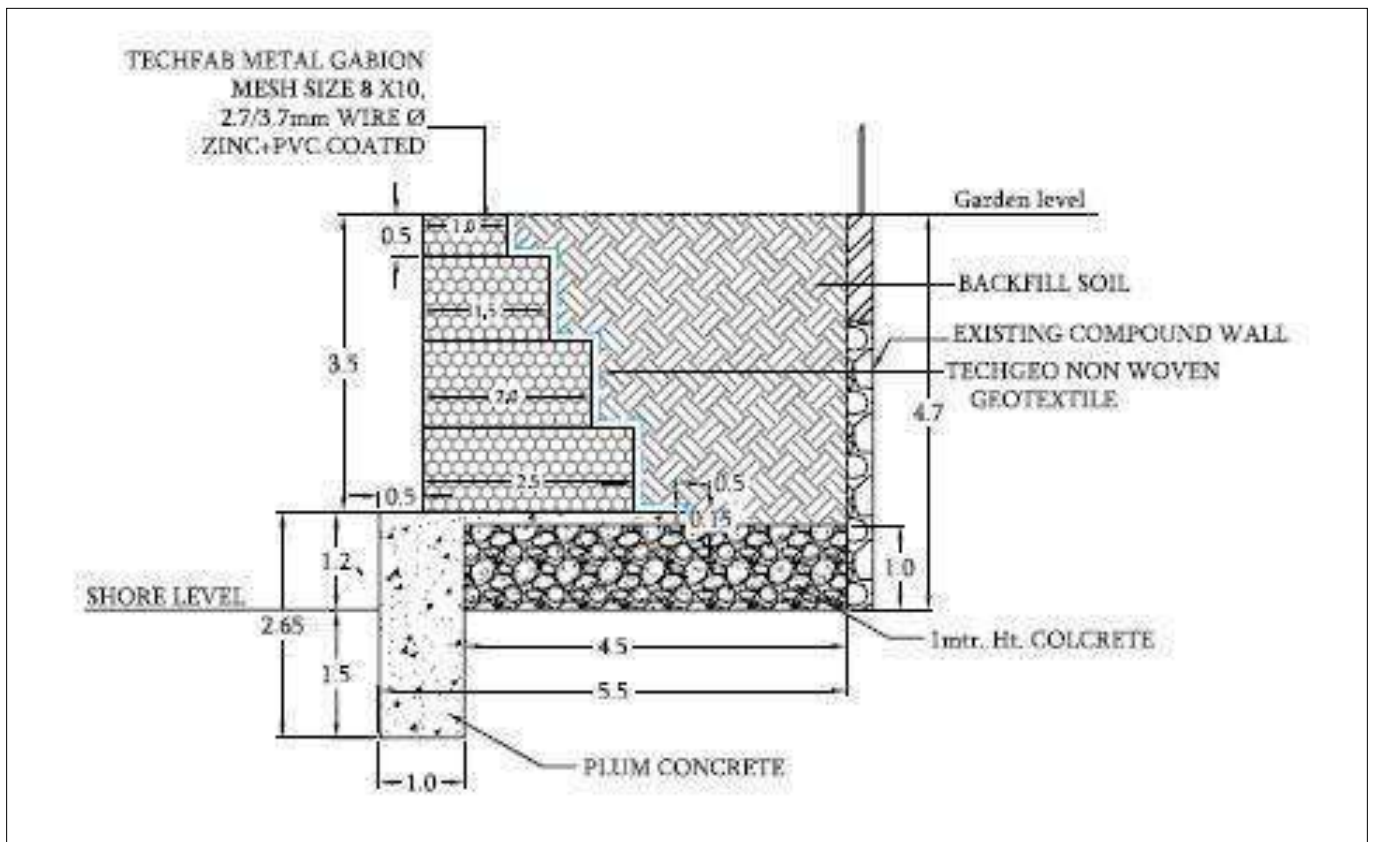

Typical Cross section of 3.5m High Gabion Retaining Wall with TechFab Metal Gabion



Photo 2 : TechFab Metal Gabion Installation



Photo 3 : TechFab Metal Gabion - Back view



Photo 4 : Completed Structure

Conclusion:

The project was successfully completed.

For further details kindly contact :

TechFab India Industries Ltd.

711/712, Embassy Centre, Nariman Point, Mumbai – 400021

Tel: + 91– 22 - 2287 6224 / 6225 Fax: + 91– 22 - 2287 6218

E: info@techfabindia.com

W: www.techfabindia.com

CASE HISTORY

Rev:00, Date : 07.01.2022

REINFORCED SOIL STRUCTURE TO SUPPORT BOW STRING BRIDGE AT KONDAPOCHAMMA SAGAR RESERVOIR, KALESHWARAM, TELANGANA

KALESHWARAM, TELANGANA, INDIA



Reinforced Soil Wall

Client:	Products used & Quantity supplied:
GOVERNMENT OF TELANGANA IRRIGATION & C.A.D. DEPARTMENT	• TECHFAB METAL GABION - 8X10 - 2X1X0.8 - ZN+10%AL+PVC - 3000 CUM.
Main contractor:	• 0.3m THICK TECHFAB METAL GABION MATTRESS - 6X8 - ZN+10%AL+PVC - 1770 SQM.
KNR CONSTRUCTIONS LTD.	• TECHSTRAP GEOSTRIPS TS40 - 67,450 M
Consultant:	• TECHGEO NONWOVEN GTX. PR 40 - 4600 SQM.
IITH - PROF. B UMASHANKAR	
Manufacturer & Supplier:	Year of construction:
TECHFAB (INDIA) INDUSTRIES LTD.	2021

Project brief:

The Kondapochamma Sagar reservoir, located around 50 km from Hyderabad. This reservoir is another milestone in the multi-stage Kaleshwaram Lift Irrigation Scheme (KLIS) and was inaugurated in the last week of May 2020 by Telangana Chief Minister K Chandrashekhar Rao. This reservoir was constructed as part of the Telangana government's efforts to make Godavari a perennial river. The Kondapochamma Sagar reservoir receives water from the Markook surge pool, which in turn receives water from Akkaram pump-house.

The 15.8 kilometre-long Kondapochamma Sagar has a capacity of 15 TMC. Its full-reservoir level is 618 m and is envisaged to provide irrigation to more than two lakh acres of ayacuts through 13 canals.

The end of bow string walkway bridge of reservoir needs to rest about 18m inward (towards reservoir side) from the edge of the top of the embankment at level + 622.300. Hence, a widening over 20m was desired from the top of the embankment. Intake wells were inside the reservoir. To connect the embankment with the intake wells, bowstring bridges were adopted.

The present slope of the embankment was 1V: 2.5H. A steeper slope was needed to accommodate the seating of bowstring walkway bridge over the embankment. In order to create additional space adjoining to this is an existing embankment and to support the bow string walkway bridge, a reinforced soil structure was envisioned.



Photo 1 : Photograph of Reservoir before construction of Reinforced Soil Wall

Solution:

In order to create the additional space, a reinforced soil wall with Gabion fascia and Techstrap Geostrips reinforcement were decided to be adopted after evaluating various available options. The total vertical height of reinforced soil wall to be constructed was 16m (from +606.300 to +622.300). Hence, a two tiered reinforced soil wall with no superimposed load from top wall on the bottom wall was found appropriate. Tiered wall ensured minimal reinforcement length to fulfill the need of the site not to disturb the core clay of the embankment.

The vertical exposed height was kept at 8.0m and the wall was to be raised to level +622.300 from a level +606.300 leaving a 3m berm in front of the toe of the wall. Considering the sloping surface in front of the reinforced soil wall and a waterfront structure, an embedment of 1.6m was considered.

And a gabion mattress in front of the reinforced soil wall (both top and bottom walls) was recommended to avoid the scour of the toe of the structure. It was proposed to have a graded filling material inside the gabions to protect the backfill from erosion.

TechStrap Geostrips are geosynthetic strips specially engineered for the reinforcement of soils and other fills for the for the construction of reinforced soil walls. TechStrap Geostrips comprise a core of closely packed and tensioned high tenacity polyester filament yarn tendons encased in a sheath of linear low density polyethylene. We have suggested TechStrap Geostrips of tensile strength equal to 40kN (width of 85mm with long-term design strength of 22.3 kN and a coefficient of interaction (conservatively) taken as 0.7- 0.8) is selected for the purpose of designing the structure. The TechStrap Geostrip was more suitable as a soil reinforcement considering the lower possible installation damages to the material.

The structure was designed to take the loading of the bowstring walkway bridge. The wall is a two-tiered wall.

Also we have proposed TechCell Geocell filled with aggregate granular material as a reinforced foundation soil bed to support the loads coming from the bearing plate on the top reinforced soil wall.

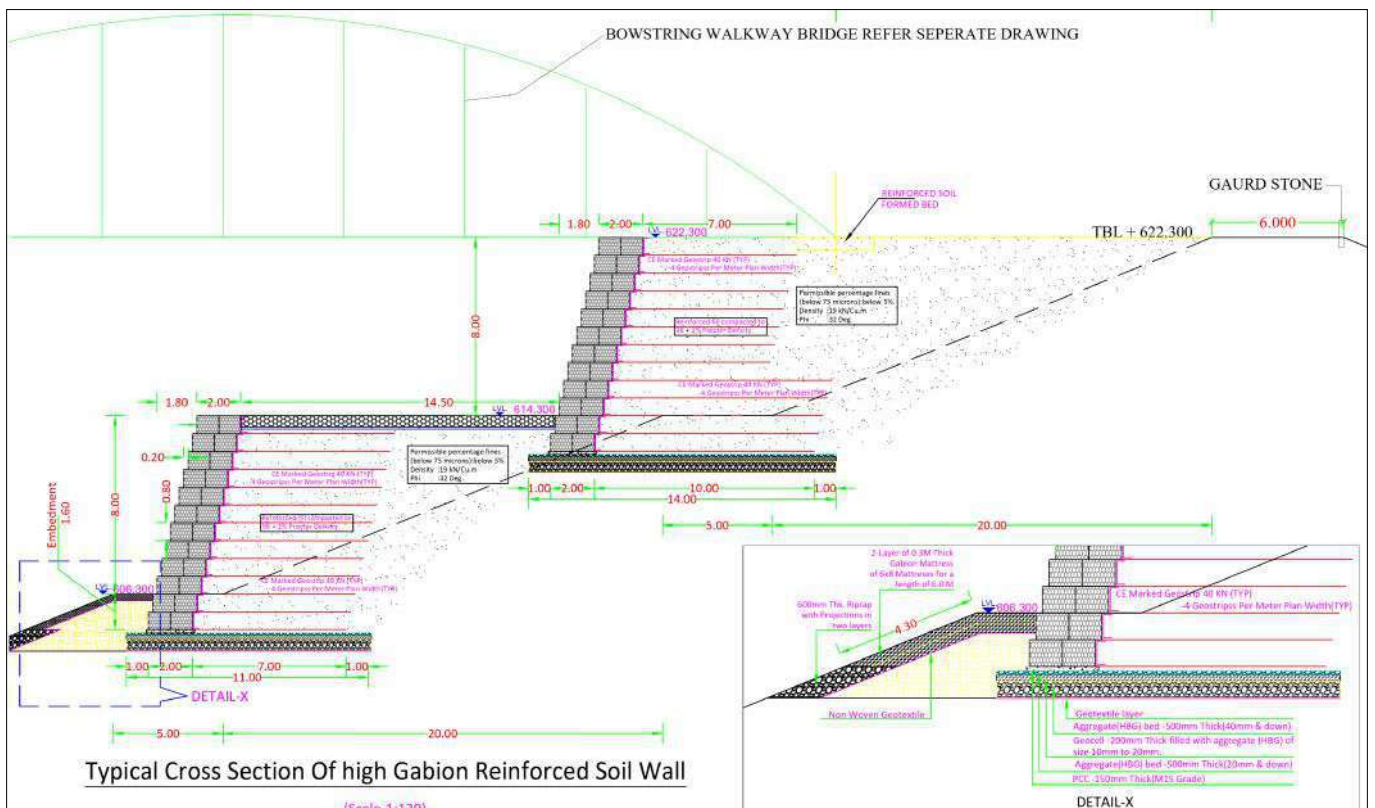

Typical Cross Section Drawing of Reinforced Soil Wall



Photo 2 : During Construction - TechStrap Geostrips installation



Photo 3 : Installation of Gabion fascia units on Top wall



Photo 4 : During Construction - Top Wall



Photo 5 : Installation of Gabion fascia units on Top wall



Photo 6 : Top view of the Structure



Photo 7 : Photograph of Completed Structure

Conclusion:

The construction of Reinforced Soil Wall is completed successfully. Extremely satisfied with the structure workmanship and materials, the department has decided to adopt the same system for the other two intake wells.

For further details kindly contact :

TechFab India Industries Ltd.

711/712, Embassy Centre, Nariman Point, Mumbai - 400021

Tel: + 91- 22 - 2287 6224 / 6225 Fax: + 91- 22 - 2287 6218

Email : info@techfabindia.com

Website : www.techfabindia.com

CASE HISTORY

Rev:00, Date : 26.12.2020

RIVER BANK PROTECTION & LAND RECLAMATION WITH TECHFAB METAL GABION REINFORCED SOIL WALL FOR INEOS STARLUTION AT KATOL VILLAGE, GUJARAT
KATOL, GUJARAT, INDIA



Land Reclamation and River Bank Protection Works

Client:	Products used & Quantity Supplied:
INEOS STYROLUTION INDIA LIMITED	•TECHFAB METAL GABION 10X12, ZN+PVC COATED 2X1X0.8 - 926 NO'S •TECHFAB METAL GABION MATTRESS 10X12, ZN+PVC COATED, 0.3m THICK - 326 SQM •TECHGRID GEOGRID (TGU) - 15,500 SQM •NONWOVEN GEOTEXTILE PR 20 - 3250 SQM
Consultant:	
B.R. PATEL ASSOCIATES, VADODARA, GUJARAT	
Main contractor:	Year of construction:
UNITED CONSTRUCTIONS	2020
Manufacturer & Supplier:	
TECHFAB (INDIA) INDUSTRIES LTD.	

Problem:

INEOS Styrolution is a global styrenics supplier and is headquartered in Germany. It is a subcompany of INEOS and provides styrenics applications for many everyday products across a broad range of industries, including automotive, electronics, household, construction, healthcare, packaging and toys/sports/leisure. One of its plants is situated at Katol village on the bank of Orsang river. Orsang is the biggest river of Chhota Udaipur district. It is the main source of the sand in this region. In 2018, Heavy rain has caused flooding in Katol and nearly 4,000 people became homeless and were relocated to safer place by NDRF commanders.

Almost every year, Orsang river overflows due to heavy rain. As this plant is situated on the bank of Orsang river, the land adjoining the bank gets severely eroded due to high discharge and velocity during monsoon. The height of the river bank which was to be protected was varying from 3m to 9.6m. The length of the stretch to be protected was approximately 184m.

The client desired to adopt a solution that is technically superior and commercially viable to the heavy erosion problem as well as for the reclamation of land on the sides of the river.



Orsang river bank - Before Construction

Solution:

As the site is in high flood zone it was necessary to provide a retaining structure which is flexible, permeable, cost effective and environmental friendly. Based upon the site conditions and project requirements, TechFab India has proposed to construct Reinforced Soil Wall with Gabion Fascia which will provide a sustainable , environmentally friendly solution for this project. The sedimentation of soil transported by water will take place in the voids between stones and the eventual appearance of vegetation, increases monolithicity, improving the static characteristics of the structure over time.

This system was adopted by the client as it could serve the purpose of stabilizing the river bank adapting to the differential hydrostatic pressures as well as the reclamation of the land could be done in an effective manner.

The typical cross-section drawing for Gabion Fascia Reinforced Soil Wall is as follows: , which shows the Techfab Metal Gabions as Fascia and Techgrid Geogrid as High strength Geogrid Reinforcement and Techgeo Nonwoven Geotextile as filter media behind the Gabion fascia. The maximum height of retention in this project is around 9.6m, to protect the wall foundation from scouring flexible launching apron with Gabion Mattress is suggested at the river bed level.

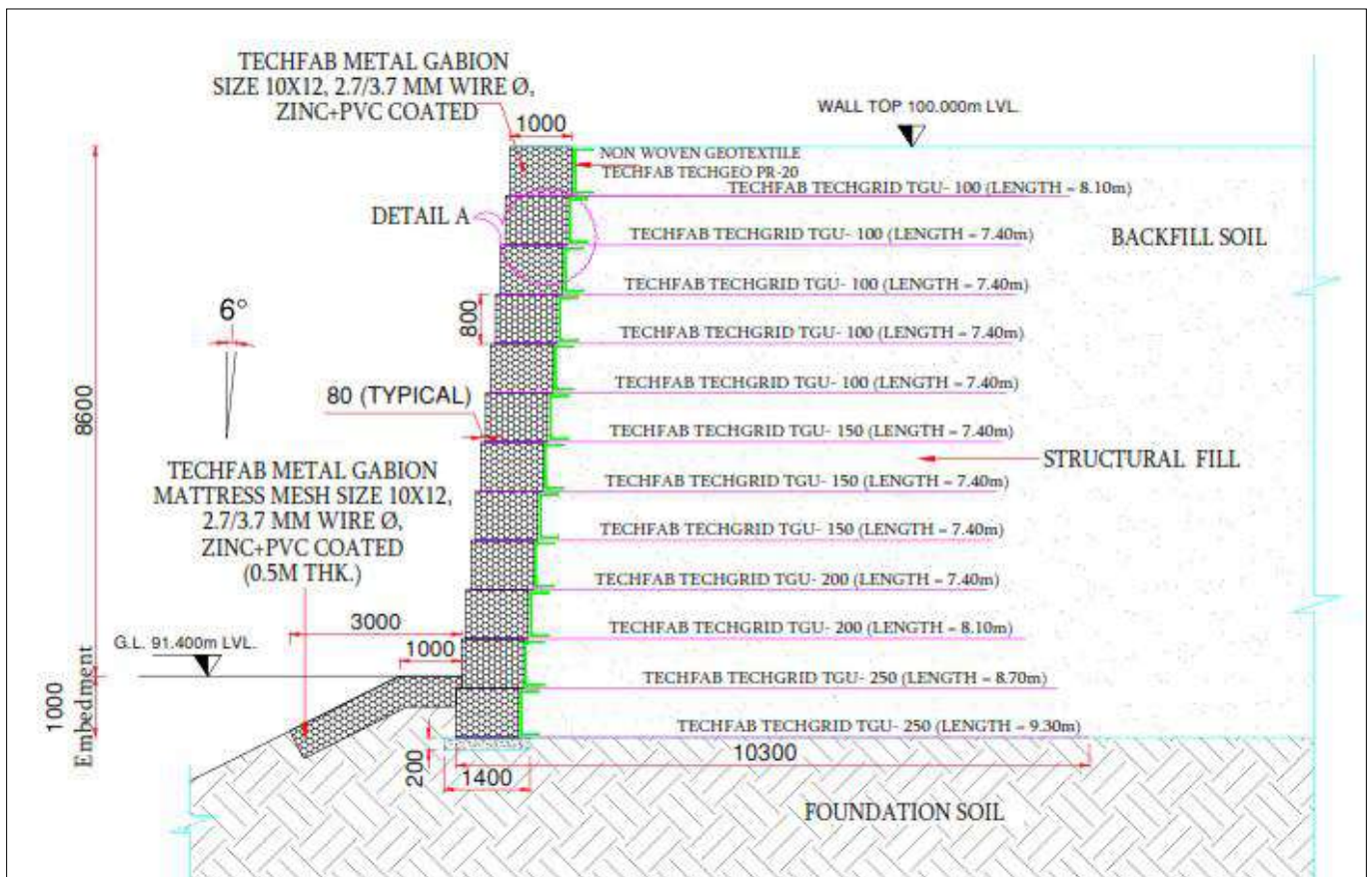

Typical Cross Section drawing of Reinforced Soil Wall

Advantages of Gabion Fascia Reinforced Soil walls over Conventional RCC Retaining Wall :

- The proposed system did not require heavier or/and deeper foundation as required for conventional RCC retaining wall.
- The Gabion fascia of the system is permeable in nature and allows the water to drain off and Non-Woven Geotextile behind the fascia did not allow the soil to pass through so the combine system will drain off the excess water from the backfill. This process restricts the build-up of hydrostatic pressure.
- The proposed system enables to withstand differential settlement without affecting the integrity of the structure
- Vegetation was permitted to grow with the system, thus enabling it to blend into the natural environment and roots of the vegetation further increase the strength of the structure. which is not the case in RCC/Masonry Retaining Structure.
- The Gabion Fascia Reinforced Soil Walls are more cost-efficient and can construct speedily compare to any other similar Rigid structure.



Preparing site with proper surface



Installation of Gabion fascia units



Installation of TechGrid Geogrid



Compaction behind the wall



Work under Construction - Gabion Facia & Mattress Installation



During Construction Photograph



Reinforced Soil Wall with Gabion facia

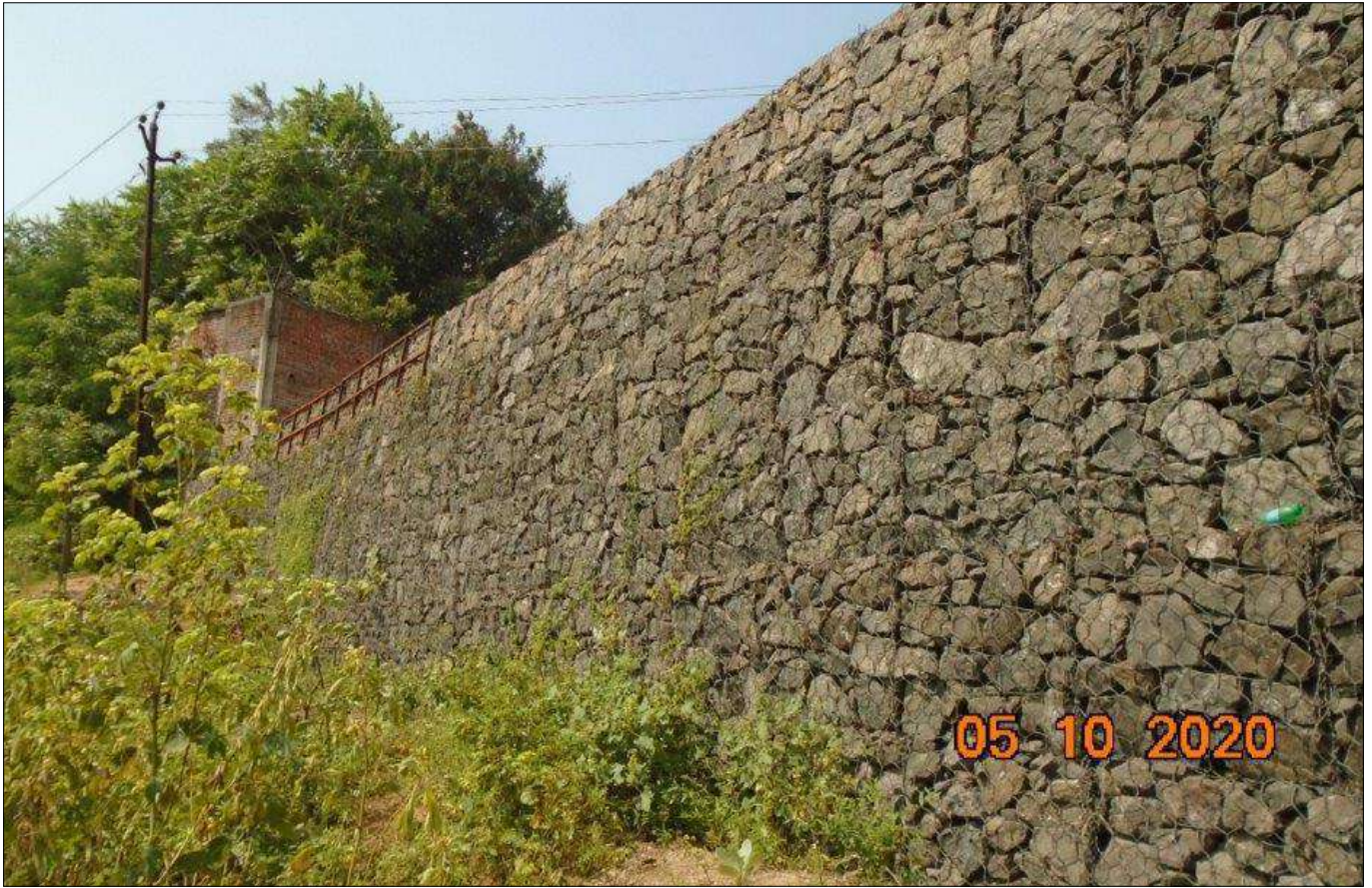

Reinforced Soil Wall with Gabion facia



Top view of Wall



Completed Structure

Conclusion:

The Project is completed successfully and serving its purpose. The client was very happy and satisfied with product quality of TechFab India Industries Ltd.

For further details kindly contact :

TechFab India Industries Ltd.

711/712, Embassy Centre, Nariman Point, Mumbai – 400021
Tel: + 91- 22 - 2287 6224 / 6225 Fax: + 91- 22 - 2287 6218
E: info@techfabindia.com
W: www.techfabindia.com

CASE HISTORY

Rev:00, Date : 04.08.2020

RIVER BANK PROTECTION WORK AT ORSANG RIVER WITH TECHFAB METAL GABION REINFORCED SOIL WALL FOR BAPS TEMPLE, BODELI, GUJARAT BODELI, GUJARAT, INDIA



River Training Works

Client:	Products used & Quantity Supplied:
B.A.P.S SWAMINARAYAN TEMPLE, GUJARAT	• TECHFAB METAL GABION 10X12, ZN+PVC COATED 2X1X0.8 - 1079 NOS & 3X2X0.3 - 113 NOS • TECHGRID GEOGRID - TGU 100 - 5100 SQM, TGU 150 - 4590 SQM & TGU 200 - 1530 SQM • NONWOVEN GEOTEXTILE PR 20 - 3350 SQM
Consultant:	
B.R. PATEL ASSOCIATES, VADODARA, GUJARAT	
Main contractor:	
TAHIR MEMON, BODELI, GUJARAT	
Manufacturer & Supplier:	Year of construction:
TECHFAB (INDIA) INDUSTRIES LTD.	2019

Problem:

BAPS temple at Bodeli is situated on the Orsang river bank. Orsang is the biggest river of Chhota Udaipur district. It is the main source of the sand in this area. In 2018, Heavy rain has caused flooding in Bodeli. Nearly 4,000 people become homeless and were relocated to safer place by NDRF commanders.

The devastating floods not only result in loss of precious human lives, cattle and damage to public and private property but also create a sense of insecurity and fear in the minds of people living in the flood plains. Almost every year, Orsang river overflowing due to heavy rain in Chhota Udaipur. BAPS temple being at the bank of the river, prone to river bank erosion and flood damage.

However, the softer forms of erosion protection are not appropriate for situations where flow velocities or turbulence are high. Whereas the achievement of an environmentally acceptable protection system is very important, this has to be in the context of achieving the primary aim of bank stabilization.



BAPS Shri Swaminarayan Temple

Solution:

To protect temple in case of flood situation, BAPS authority wanted a solution to reduce the flood/erosion losses and protect the flood plains near the temple area. After discussion of BAPS Temple Authority officials, consultant & Techfab Engineers it was decided to propose the system which will help to reclaim the eroded land.

Based upon the site conditions and project requirements, the engineering team has decided to construct Reinforced Soil Wall with Gabion Fascia which will provide a sustainable, environmentally friendly solutions for this project. The composite design used as a reinforced soil wall with Gabion as fascia, which is an extremely effective solution for riverbank protection work and land reclamation of eroded land.

The typical cross-section drawing for Gabion Fascia Reinforced Soil Wall is as follows: , which shows the Techfab Metal Gabions as Fascia and Techgrid Geogrid as High strength Geogrid Reinforcement and Techgeo Nonwoven Geotextile as filter media behind the Gabion fascia. The maximum height of retention in this project is around 8.8m, to protect the wall foundation from scouring flexible launching apron with Gabion Mattress is suggested at the river bed level.

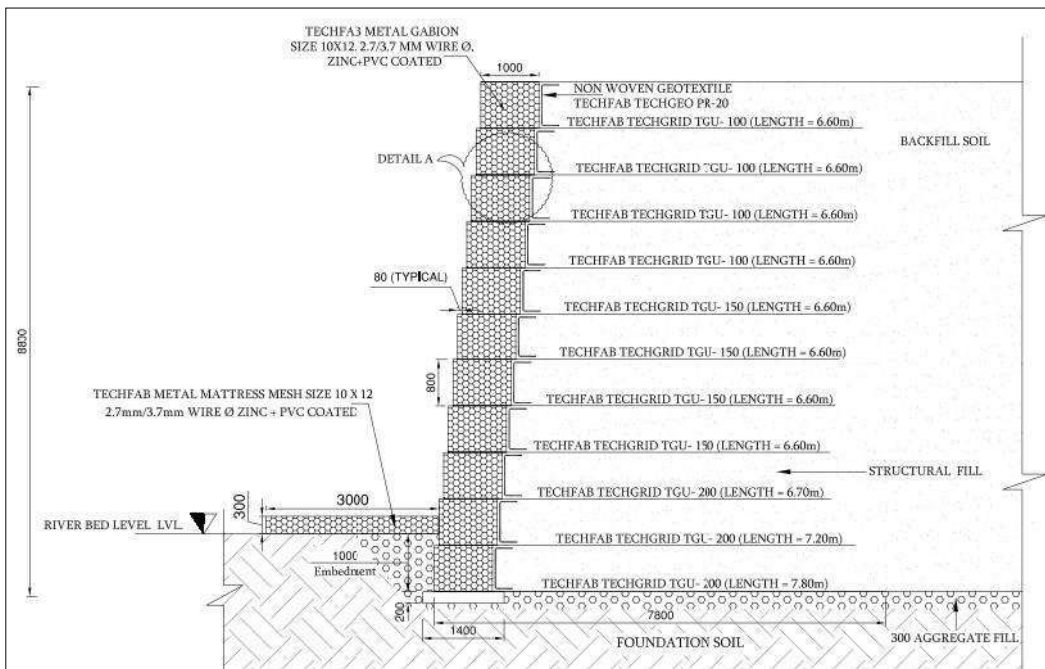

Typical Cross Section Drawing



During Construction Photographs

Advantages of Gabion Fascia Reinforced Soil walls over Conventional Retaining Wall :

- The proposed system did not require the heavier or/and deeper foundation that a conventional retaining wall would have.
- The Gabion fascia of the system is permeable in nature and allows the water to drain off and Non-Woven Geotextile behind the fascia did not allow the soil to pass through so the combine system will drain off the excess water from the backfill and restrict the building up of hydrostatic pressure.
- The proposed system enables to withstand differential settlement without affecting the integrity of the structure
- Vegetation was permitted to grow with the system, thus enabling it to blend into the natural environment and roots of the vegetation further increase the strength of the structure. which is not the case in RCC/Masonry Retaining Structure.
- The Gabion Fascia Reinforced Soil Walls are more cost-efficient and can construct speedily compare to any other similar Rigid structure.



During Construction Photograph



During Construction Photograph

Conclusion:

The temple authority and Consultant are very happy with the technical support provided by TechFab team during the entire period i.e. from design, training, implementation, and completion of the project. Immediately after the completion of the structure, it has witnessed the flood of 2019 in Orsang river, and structure is in well condition and serves the purpose for which it constructed.

For further details kindly contact :

TechFab India Industries Ltd.

711/712, Embassy Centre, Nariman Point, Mumbai – 400021
Tel: + 91- 22 - 2287 6224 / 6225 Fax: + 91- 22 - 2287 6218
E: info@techfabindia.com
W: www.techfabindia.com

RIVER TRAINING WITH GABION FASCIA REINFORCED SOIL WALL FOR GADHI RIVER ALONG NAVI MUMBAI INTERNATIONAL AIRPORT, NAVI MUMBAI
 NAVI MUMBAI, MAHARASHTRA, INDIA

River Training Works

Client:	Products used & Quantity Supplied:
CITY AND INDUSTRIAL DEVELOPMENT CORPORATION (CIDCO), NAVI MUMBAI	<ul style="list-style-type: none"> • TECHFAB METAL GABION (ZINC 90% + AL 10%)+ PVC COATED • TECHGEO NON WOVEN GEOTEXTILE PR-20 • TECHFAB GABION MATTRESS (ZINC 90% + AL 10%)+PVC COATED • TECHGRID HIGH STRENGTH POLYESTER GEOGRID TGU - 100 & 200
Main contractor:	
Manufacturer & Supplier:	
TECHFAB (INDIA) INDUSTRIES LTD.	
Year of construction:	
2019	

Project description:

Due to the increased air-traffic at existing Mumbai Airport, a need for a new airport was suggested since many decades. To meet the growing need of the requirement, City and Industrial Development Corporation (CIDCO) proposed an International airport at Kopar in Raigad District of Maharashtra.

The Proposed Navi Mumbai International Airport is located on the banks of Gadhi River near Panvel Creek. Around 1600 hectares of land is required to be reclaimed in the region of Panvel Creek including Gadhi River basin. Therefore it is decided to train the Gadhi River along the airport premises to retain the Backfill soil material on upstream side from the flooding during heavy monsoons and drawdown during the dry season. (Ref below figure left portion shows reclaimed land and Trained Gadhi River)



Figure 1 : Proposed plan of River training work at Gadhi River, Navi Mumbai International Airport

Problem:

Gadhi River is the main river of the Panvel creek with a hard rock bedding surface as shown in Figure 1. Due to Industrial and Residential development around adjacent Panvel city, The Gadhi River is frequently subjected with storms from Thane creek resulting in rise of water levels.

The river had a HFL (high flood level) of 6.50m during the July 2005 flood. Thus a safe-grade elevation of 9m from bed rock level was proposed for Airport location. A Retaining wall was proposed to train the Gadhi River along the Panvel creek.



Figure 2 : Photographs of Catchment area of Gadhi River with Inundated rock formations

Solution:

Looking to the site conditions and project needs it is decided to go for solution which is sustainable and environment friendly which blend with the nature, so it is decided to go for composite reinforced soil wall with gabion as fascia which is most viable solution for land reclamation and river training project.

Composite Reinforced soil wall consists of high strength Polyester Uniaxial Geogrid i.e. TechGrid (TGU) as reinforcing material and TechFab Metal Gabion as fascia with GI wire mesh having special coating of zinc90% +Al10%+ PVC Coating.

The Techgrid Geogrid Uniaxial acts as soil reinforcement & TechFab Metal Gabion with stone fillings gives strong, durable and flexible fascia which also give excellent erosion protection to the entire system and protect the backfill material, porosity of Gabion fascia system allow the dissipation of pore water pressure from the backfill material as and when require, and TechGeo Nonwoven Geotextile permits the water to move through the soil while retaining all upstream soil particles. It is used to prevent soils from migrating into drainage aggregate or pipes while maintaining flow throughout the system and maintain system integrity.

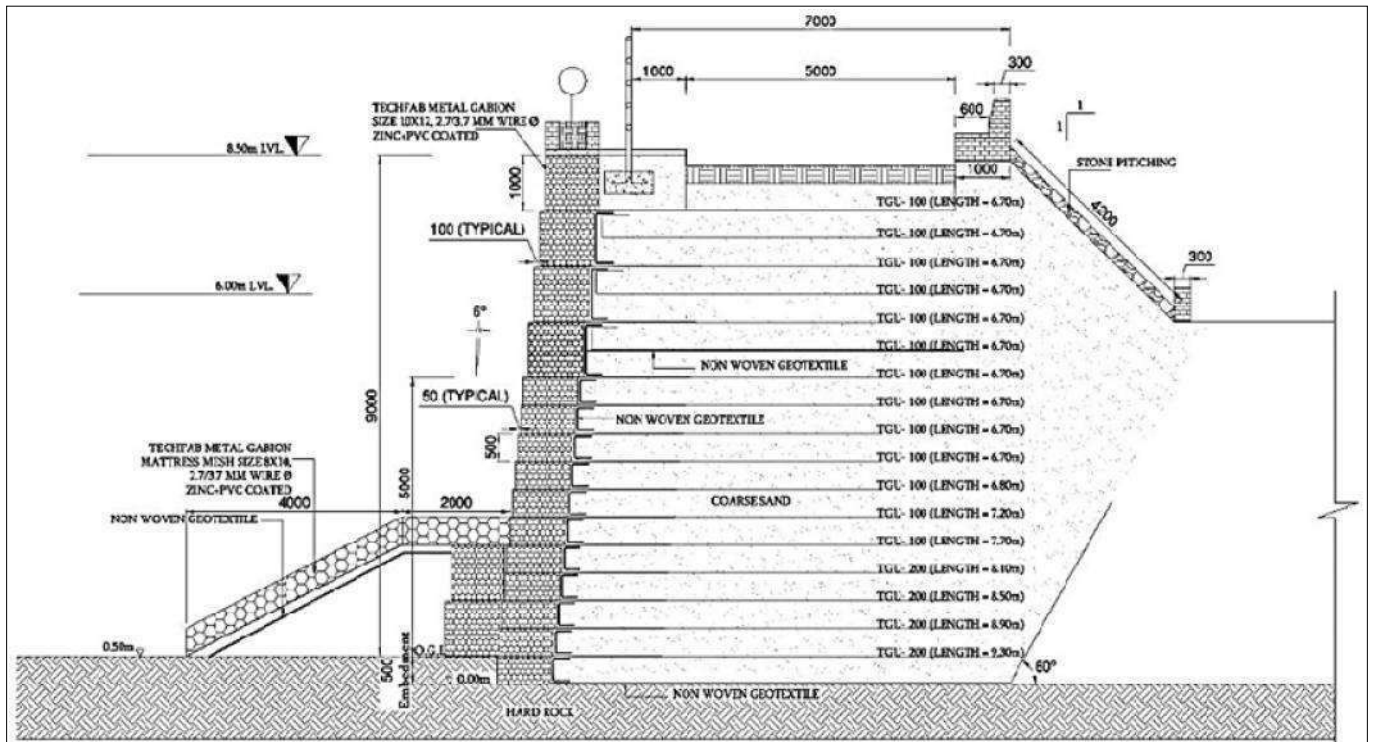

Figure 3 : Typical Cross Section of Reinforced Soil Wall with Gabion Fascia

Techgrid were laid with the TechFab Metal Gabion along with 12mm connector rod as shown in the sketch below, U-pins were used to fix the position in the reinforcing zone.

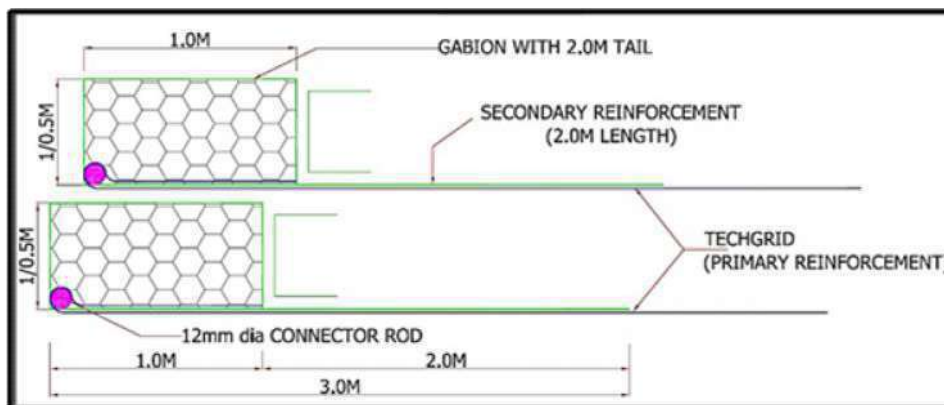

Figure 4 : Arrangement of Gabion Mesh with connector rod

The reinforced soil wall was designed using BS 8006 design standards and Gabion mattress were provided with a height of 2.5m from the hard Rock level to prevent inundation and sliding at the Toe portion of the Retaining wall. Maximum height of Reinforced soil wall constructed here is of 11.5 m.



Figure 5 & 6 : Installation, Filling of Gabion mesh with stone in progress



Figure 7 : Compaction behind the wall in progress

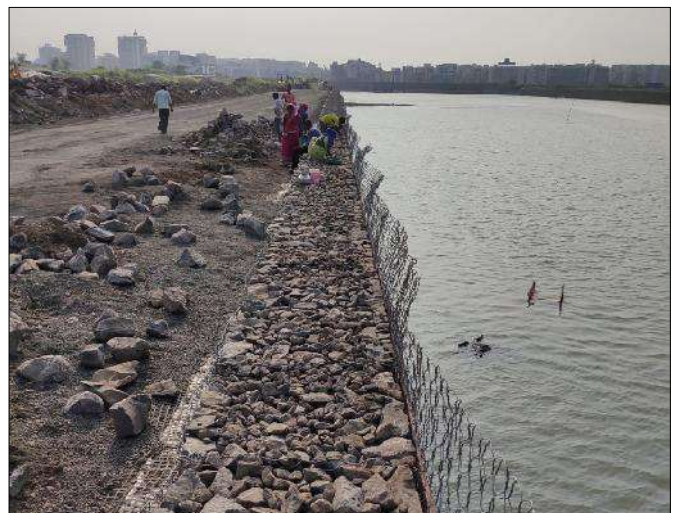

Figure 8 & 9 : Installation, Filling of Gabion mesh with stone in progress

The benefits of Gabion Fascia Composite Reinforced Soil Wall System:

- Compare to other Conventional/ classical walls, no heavy or deeper foundation requires.
- The permeable nature of the TechFab Metal Gabion eliminates buildup of hydrostatic pressure behind the retaining structure and uplifts caused by turbulent flows.
- As the reinforced soil wall is with flexible fascia it withstands differential settlement without fracturing the structure particularly when a structure is installed on unstable and uneven ground or in an area where scours from waves or current can undermine etc.
- Permit the growth of vegetation and blend with the existing environment.
- More cost-efficient and efficient structures than any other rigid similar function structures.
- Compared to conventional concrete walls the construction period required to carry out the Composite RS wall is fast and cheap.



Figure 10 & 11 : Photographs of Completed Reinforced soil wall with Gabion Fascia



Figure 12 : Completed Structure

Conclusion:

The project was completed successfully. The client was very happy and satisfied with product quality as well as quality of work by TechFab India industries Ltd.

For further details kindly contact :

TechFab India Industries Ltd.

711/712, Embassy Centre, Nariman Point, Mumbai – 400021
Tel: + 91- 22 - 2287 6224 / 6225 Fax: + 91- 22 - 2287 6218
E: info@techfabindia.com
W: www.techfabindia.com

CASE HISTORY

Rev:00, Date : 15.01.2021

REINFORCED SOIL WALL FOR BRIDGE APPROACH AND RECONSTRUCTION OF ROB 39A AT GONDAL RAILWAY PORTION, GUJARAT

GONDAL, GUJARAT, INDIA



Reinforced Soil Wall using Panel Facia & Techstrap Reinforcement

Client:	Products used:
KEVAL CONSTRUCTION	TECHSTRAP POLYMERIC STRIP
Main contractor:	Quantity supplied:
SANJAY CONSTRUCTION	72473 rm
Manufacturer & Supplier:	Year of construction:
TECHFAB (INDIA) INDUSTRIES LTD.	NOV 2019 - OCT 2020

Problem:

The project scope included reconstruction of ROB in the prime area of Gondal (Gujarat), wherein the alignment of old ROB was in skew. Considering the city congestion and adjoining private lands, alternate alignments were not an option. For the current structure, maximum height of retaining wall was evaluated to be approximately 11m.

With due consideration to limited right of way; minimizing land acquisition; poor ground conditions; economy and speed of construction, the consultant has recommended to adopt reinforced soil structure for the approached of ROB in the current project.

Solution:

Pursuing the detailed geotechnical investigations and the site conditions, it was decided to adopt the reinforced soil wall with panel facia and TechStrap (Geostrap) as reinforcement compared to other alternatives such as RCC retaining walls / gabion gravity walls etc. Following are some of the advantages of adopting reinforced soil walls with panel facia and techstrap reinforcement:

- Simple and rapid construction procedures and do not require heavy machinery / equipment
- Construction space requirements shall be minimal in front of the structure.
- Pore-water pressure will not be developed.
- Its flexible in nature which can to absorb deformations.
- Deep foundation were not required as less pressures will be exerted on the foundation soil.
- Cost effective and aesthetically pleasing compared to other alternatives.

What is TechStrap Polymeric Strip reinforcement?

TechStrap are geosynthetic straps (polymeric strips/straps with a flat webbing like structure) specifically engineered for the reinforcement of soils and other fills in the construction of reinforced soil or mechanically stabilised earth structures. TechStrap Polymeric strips comprises a core of closely packed and tensioned high tenacity polyester filament yarn tendons encased in a tough and flexible sheath of linear low density polyethylene.

Advantages of TechStrap Polymeric Strip

- High tensile strength and modulus
- Low creep
- High resistance to weathering, installation damage
- High resistance to chemical and biological resistance
- Efficient and economic design
- Easy and fast construction
- Excellent frictional interaction with fill
- Efficient, strong and durable connection with pre-cast concrete discrete panels
- Excellent performance and durability

Proposed typical cross section drawing for variable height is as given below:

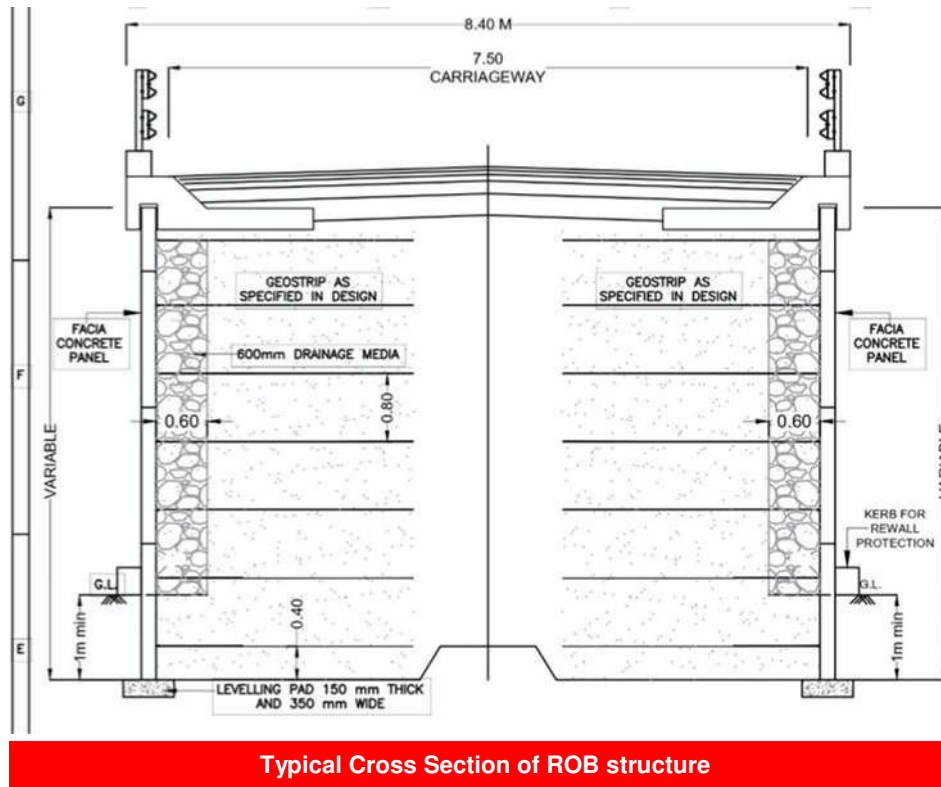

Based on height of RS wall and structural fill soil conditions, strength of Polymeric strip and length of reinforcement was designed.

Installation Method

EXCAVATION AND FOUNDATION PREPARATION

- The site was excavated to the width and depth as per the approved construction drawings. The trench for the leveling pad was excavated to the correct depth and width.
- Any pits, depressions etc. were filled by compacted granular fill of approved quality. Roller was passed over the excavated ground for even finish and requirements of bearing capacity and density was checked as per the design requirements before proceeding with further construction.

FOUNDATION LEVELING PADS

- The centerline of the leveling pad was marked on the base of the trench.
- Side forms were fixed for the leveling pad.
- After pouring concrete and completion of curing period, forms were removed.

ERECTION OF FIRST COURSE OF PANELS

- Chalk line was marked on the leveling pad to coincide with front face of the bottom most panels.
- The first full height panel was positioned on the leveling pad with its front face aligned along the chalk line. The panel was set to the correct inward batter (1°) by inserting the hardwood wedges below the base of the panels.
- Bracings were installed for the panel.
- The sequence was continued till all the panels in first row are placed. The clamps were fixed loosely.
- Vertical construction joint were provided wherever concrete and foundation soil intersects.
- For vertical construction joints; cut panels were used at junction, top to bottom, to avoid differential settlement.
- Geotextile filter straps were installed for vertical joints.

PLACEMENT AND COMPACTION OF FILL UP TO FIRST LAYER OF TECHSTRAP

- Fill material satisfying project requirements (as per design consideration and fill material mentioned in this methodology) was used.
- Backfill was placed and compacted in lifts up to the first layer of TechStrap reinforcement. The deposition, spreading, leveling and compaction of the fill was carried out in a direction parallel to the facing
- Compaction of the fill was carried out using appropriate equipment, which will not induce excessive loads on the panels and at the same time achieves the required compaction. (as mentioned in drawing)
- Fill was placed and compacted in lifts. Thickness of lift (not more than 200mm) was consistent with the compaction equipment used and the degree of compaction to be achieved. If necessary, water was sprinkled to bring the water content close to the optimum moisture content.
- The dry density of the compacted fill was checked as per codes.



Erection of RCC Facia Panel in Progress



Installation of top layer TechStrap Polymeric Strip

INSTALLATION OF FIRST LAYER OF TECHSTRAP REINFORCEMENT

- The required length of reinforcement was marked on Techstrap as per drawings and the rear anchors which comprised of J hooks and connector rods were fixed as per design provided. The rear anchor arrangement consist of 2 No.'s of J hooks (as specified) fixed at 150mm gap, a rod (as specified) shall be passed and fixed between the hooks.
- The rear anchor arrangement was used temporary till backfill was placed and compacted over the TechStraps.
- TechStrap of required type and length was positioned, as shown on RS Wall L-section drawings.
- The rear end of the TechStrap was fixed by looping at rear anchor proving 2m overlap, the open end was fixed by placing small heaps of fill and using steel clamps/ U pins (depth of U pins 200mm minimum) in tensile strength direction.
- TechStrap was passed through the connector looping around the bar inside and continued laying back towards rear end and return towards the adjacent connector, repeat these steps till TechStraps are laid over the required area.
- TechStraps was pulled and fixed ensuring that TechStrap was reasonably tight and free from wrinkles and folds. Loop the final length of TechStrap around rear anchor with 2m overlap and the open end was fixed using steel clamps/ U pins.
- Panels were placed and compacted fill up to the top of first row of Panels.

ERECTION OF SUBSEQUENT COURSES OF PANELS, FILLING AND INSTALLING TECHSTRAP REINFORCEMENT

- Cycle of backfilling and compacting in lifts, placing GeoStraps, and setting panels was repeated until design height was reached.
- Drainage layer was placed as mentioned in the drawing.

COPING BEAM

- At the top of the upper most panels, a cast in-situ coping beam was provided to achieve the required longitudinal profile.



Coping beam installation completed



Completed longitudinal road profile



Completed Reinforced Soil Wall with Panel Facia and TechStrap Reinforcement

Conclusion:

The project was successfully completed in October 2020.

For further details kindly contact :

TechFab India Industries Ltd.

711/712, Embassy Centre, Nariman Point, Mumbai – 400021

Tel: + 91- 22 - 2287 6224 / 6225 Fax: + 91- 22 - 2287 6218

E: info@techfabindia.com

W: www.techfabindia.com

CASE HISTORY

Rev:01, Date : 14.08.2020

CONSTRUCTION OF REINFORCED SOIL WALL & GABION RETAINING WALL FOR SOIL STABILIZATION AT MUDKHED, MAHARASHTRA

MUDKHED, MAHARASHTRA, INDIA



Soil Stabilization

Client:	Products used & Quantity supplied:
PUBLIC WORKS DEPARTMENT	• TECHFAB METAL GABIONS ZINC+PVC COATED • TECHGEO NONWOVEN GEOTEXTILE PR20 • KNITTED & PVC COATED PET GEOGRIDS
Main contractor:	
SHARDA CONSTRUCTION & GANESH ENTERPRISE	
Design Concept:	
BEST GEOTECHNICS PVT LTD.	
Manufacturer & Supplier:	Year of construction:
TECHFAB (INDIA) INDUSTRIES LTD.	

Problem:

There is a requirement for Retaining structure for Rail over bridge at Mudkhed, near by the water body. It is mandatory to protect the wall against scouring. Considering the structure alignment near by the water body, need arises for detail analysis and designing of retaining wall which can withstand the water current and also to be protected against scouring. Reinforced soil wall is the cost effective solution for the retaining wall. For protection against scouring gabion wall has been proposed in front of Reinforced soil wall, near by the water body. Reinforced soil wall founded above the embankment protected with Gabion retaining wall is designed as shown in the photographs, below.



TechFab Metal Gabion - Longitudinal View



TechFab Reinforced soil wall - Installation

The Solution:

Gabion Retaining walls are constructed, to protect against scouring are flexible structures which are very suitable in case of retaining structures for protection, near by the water body. Gabions can take settlement which may occur in such regions. Walls of varying height of (2.0m to 5.0m) were proposed. TechGeo Nonwoven Geotextile PR 20 was placed at the rear end of gabion wall which acts as filter.



TechFab Metal Gabion



TechFab Reinforced soil wall

Reinforced Soil Wall is constructed for Rail over bridge at Mudkhed. Walls of varying height of (2.0m to 10.0m) were proposed using square panels (1500x1500mm). RS Wall has been proposed considering the minimum foundation depth of 1 meter in the compacted sub grade. Outside RSW, is protected with Gabion wall. Height of the Gabion wall is decided considering the HFL. Gabions are suitable for energy dissipation against water current and also protect the wall against scouring. Engineered fill with design consideration are provided as per the drawings and methodology for the RSW and Gabion wall.

Benefits of Reinforced Soil Wall and Gabion Wall over Conventional RCC Retaining Wall, for such application:

TechFab Metal Gabion was suggested for retaining and scouring protection purposes in lieu of the conventional R.C.C Retaining Wall for achieving the following advantages:

- Flexible structure compare to R.C.C Retaining wall.
- Easy in construction, as it does not require skilled labourers.
- Does not require curing time as in case of R.C.C Retaining wall.
- Energy dissipation is possible due to the voids in the boulders, and also accommodates differential settlement very well due to its flexibility.
- Cost incurred is very less compared to conventional retaining structures.

Benefits of TechGeo Nonwoven Geotextile:

- Acts as a “Filter” by preventing the backfill material from being washed out through Gabion face.
- Acts as a “Separator” between the backfill material and the Gabion fascia and thereby prevents the mixing of the two.

Conclusion:

TechFab Metal Gabion and Reinforced Soil Wall satisfied all the technical parameters for their effective usage. The execution was successfully completed in time.

For further details kindly contact :

TechFab India Industries Ltd.

711/712, Embassy Centre, Nariman Point, Mumbai – 400021

Tel: + 91– 22 - 2287 6224 / 6225 Fax: + 91– 22 - 2287 6218

E: info@techfabindia.com

W: www.techfabindia.com

CASE HISTORY

Rev:01, Date : 01.06.2020

FOUR LANING OF LUCKNOW - MUZAFFARPUR SECTION ON NH-28, CIVIL CONTRACTOR PACKAGE NO. LMNHP EW-II (WB), PACKAGE 06 (KM 208.00 - KM 251.70) INDIA



RS Wall with Descrete Panel facia

Client:	Products used:
NATIONAL HIGHWAYS AUTHORITY OF INDIA (NHA)	TECHGRID KNITTED & PVC COATED POLYESTER GEOGRID WITH TENSILE STRENGTH OF 40 TO 250 KN/m
Main contractor:	NONWOVEN GEOTEXTILE
BSCPL INFRASTRUCTURE LTD.	
Manufacturer & Supplier:	Year of construction:
TECHFAB (INDIA) INDUSTRIES LTD.	2009

Project description:

M/s BSCPL Infrastructure Limited has awarded the work of Reinforced soil wall to M/s Techfab India Industries Ltd. The scope of work include, design of reinforced soil wall, their approval, submission of drawings, supply of moulds and supervision at site. Reinforced soil wall structure with height ranging from 1.5 meter to 9.5 meter.

Project Challenges:

There is a poor soil strata area for foundation, for which the safe bearing capacity has been worked out lesser than the required bearing pressure at particular height. Need is arises for the ground improvement to increase the safe bearing capacity.

Solution:

Detailed soil investigation has been carried out and based on the borelog data, ground improvement analysis has been done with replacement at various depths from ground level with good quality granular fill. Also layers of Geosynthetic material has been suggested along with the replacement.



Photo 1 : Elevation view of RS Wall

Salient Features of the Reinforced Soil Walls :

- Wall Facing Area: 18100 Sqm.
- Wall Height: 1.5m - 7.5m and 2.0m - 9.5m
- Soil Reinforcement: TechGrid knitted & PVC coated polyester Geogrids with Tensile Strength of 40 to 250 KN/m
- Facing: Discrete Panel Fascia
- Design Methodology: BS 8006: 1995 (Static Condition)
FHWA-NHI-00-043 (Seismic Condition)
- TFIL's scope of work: Detailed Engineering designs & drawings, supply of Geogrids, supply of Moulds for Discrete Panels, Nonwoven Geotextile & Supervision of construction

Table-1 shows the property of the reinforced infill, retained fill and foundation soil taken into consideration in the designs.

Table-1

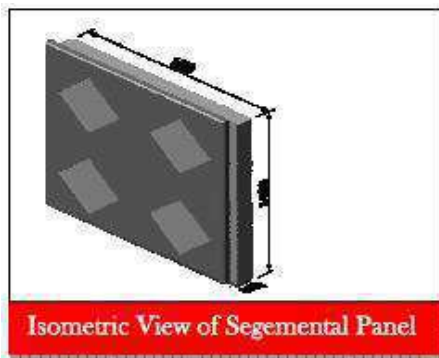

Property/Fill	Cohesion (C) - KN/m ²	Angle of Internal Friction (φ) -	Unit Weight (γ) - KN/m ³
Reinforced Infill Soil	0	30	20
Retained Soil	0	30	20
Foundation Soil	0	30	18

The design of the walls was carried out using the BS 8006: 1995 for Static Condition & FHWA-NHI-00-043 for Seismic Condition, which comprised checks for external, internal and global stability under static and seismic conditions.

Construction of the wall was carried out under the supervision of TechFab India Industries Ltd's supervision.



Photo 2 & 3: Erection of RS wall



Elevation view of RS wall

Conclusion:

The project was successfully completed in September 2009.

For further details kindly contact :

TechFab India Industries Ltd.

711/712, Embassy Centre, Nariman Point, Mumbai – 400021

Tel: + 91- 22 - 2287 6224 / 6225 Fax: + 91- 22 - 2287 6218

E: info@techfabindia.com

W: www.techfabindia.com

CASE HISTORY

Rev:01, Date : 01.09.2020

REINFORCED SOIL WALLS WITH DESCRETE PANEL FACIA SYSTEM FOR FLYOVERS & ROB'S OF NH-76, EW-II (RJ-III), UDAIPUR, RAJASTHAN
UDAIPUR, RAJASTHAN, INDIA



RS Wall with Descrete Panel facia

Client:	Products used:
NATIONAL HIGHWAYS AUTHORITY OF INDIA (NHAI)	• TECHGRID KNITTED & PVC COATED POLYESTER GEOGRID WITH TENSILE STRENGTH OF 40 TO 250 KN/m
Main contractor:	
RANJIT TARMAT - JV	• NON WOVEN GEOTEXTILE
Consultant:	
SPAN CONSULTANT	Year of construction:
Manufacturer & Supplier:	MAY 2008
TECHFAB (INDIA) INDUSTRIES LTD.	

Project description:

M/s Roman-Tarmat – a joint venture has awarded the work of Reinforced soil wall to M/s Techfab India Industries Ltd. The scope of work include, design of reinforced soil wall, their approval, submission of drawings, supply of moulds and supervision at site. Reinforced soil wall structure with height ranging from 1 meter to 10 meter, for rehabilitation and upgrading of NH-76, Gogunda to Udaipur section Km 73+000 to Km 104+724, East – west Corridor Package RJ-III.

Project Challenges:

Work done should be within the stipulated time period, which included the casting erection and casting of crash barrier as well as friction slab. Total reinforced soil wall facia is 25500 sqm.

Solution:

With the increased Nos. of Mould for panel casting and work as per the planned schedule, has completed the project within stipulated time period.



Photo 1 : Elevation view of RS Wall

Salient Features of the Reinforced Soil Walls :

- Wall Facing Area: 25500 Sqm.
- Wall Height: 10m
- Soil Reinforcement: TechGrid knitted & PVC coated polyester Geogrids with Tensile Strength of 40 to 250 KN/m
- Facing: Discrete Panel Fascia
- Design Methodology: BS 8006: 1995 (Static Condition)
FHWA-NHI-00-043 (Seismic Condition)
- TFIL's scope of work: Detailed Engineering designs & drawings, supply of Geogrids, supply of Moulds for Discrete Panels, Nonwoven Geotextile & Supervision of construction

Table-1 shows the property of the reinforced infill, retained fill and foundation soil taken into consideration in the designs.

Table-1

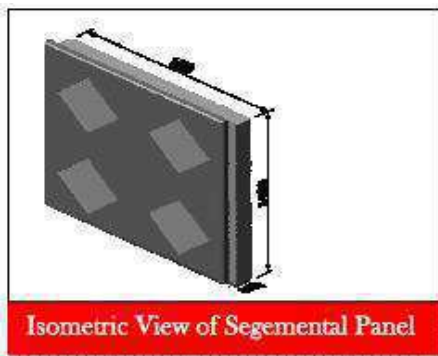

Property/Fill	Cohesion (C) - KN/m ²	Angle of Internal Friction (φ) -	Unit Weight (γ) - KN/m ³
Reinforced Infill Soil	0	34	20
Retained Soil	0	34	20
Foundation Soil	0	30	18

The design of the walls was carried out using the BS 8006: 1995 for Static Condition & FHWA-NHI-00-043 for Seismic Condition, which comprised checks for external, internal and global stability under static and seismic conditions.

Construction of the wall was carried out under the supervision of TechFab India Industries Ltd's supervision.



Erection of RS Wall

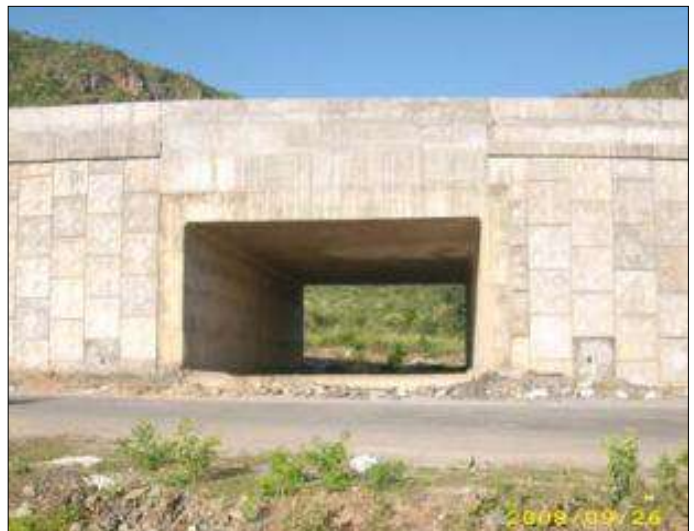

Completed RS Wall



Elevation view of RS wall

Conclusion:

The project was successfully completed in May 2008.

For further details kindly contact :

TechFab India Industries Ltd.

711/712, Embassy Centre, Nariman Point, Mumbai – 400021
Tel: + 91- 22 - 2287 6224 / 6225 Fax: + 91- 22 - 2287 6218
E: info@techfabindia.com
W: www.techfabindia.com

CASE HISTORY

Rev:01, Date : 01.06.2020

SIX LANING OF KM 108+700 TO KM 192+000 ON VADODARA - BHARUCH SECTION OF NH-8 IN THE STATE OF GUJARAT ON BOT BASIS GUJARAT, INDIA



RS Wall with Segmental Panel facia

Client:	Products used:
L&T VADODARA BHARUCH TOLLWAY LIMITED	TECHGRID KNITTED & PVC COATED POLYESTER GEOGRID WITH TENSILE STRENGTH OF 40 TO 250 KN/m
Main contractor:	NONWOVEN GEOTEXTILE
L&T ECC DIVISION, AHMEDABAD	
Manufacturer & Supplier:	Year of construction:
TECHFAB (INDIA) INDUSTRIES LTD.	AUGUST 2009

Project description:

L & T ECC Ltd. has awarded the work of Reinforced soil wall to M/s Techfab India Industries Ltd. The scope of work include, design of reinforced soil wall, their approval, submission of drawings, supply of moulds and supervision at site. There are two ROB approaches, eleven flyovers and one vehicular underpass for reinforced soil work for approaches. Total stretch length of the project is around 70 Km, which starts from Vadodara city to Bharuch city in Gujarat, India.

Project Challenges:

Area is located, where the black cotton soil is available up to the depth of 3m to 8m. It was difficult to achieve required safe bearing capacity at the depth to 1 to 1.5 meter. Maximum height of the reinforced soil wall is 10 meter as it has to connect the ROB's as well as Flyover's.



Elevation view of RS Wall

Solution:

Detailed soil investigation has been carried out to know the actual extent of black cotton soil. Area, where the depth of soil is up to 2.0 to 2.5 meter has been replaced with good quality granular fill. Other areas, where the depth of black cotton soil is on higher side, it has been replaced up-to 2.5 meter, then provide the plate form with the layers of Geosynthetic material with granular fill with maximum of 500mm to 750mm. Over the plate form leveling pad has been placed for the erection work. Also to ensure the increased safe bearing capacity, plate load test has been done for verification.

Salient Features of the Reinforced Soil Walls :

- Wall Facing Area: 68,323 Sqm.
- Wall Height: 10m
- Soil Reinforcement: TechGrid knitted & PVC coated polyester Geogrids with Tensile Strength of 40 to 250 KN/m
- Facing: Segmental Panel Fascia
- Design Methodology: BS 8006: 1995 (Static Condition)
FHWA-NHI-00-043 (Seismic Condition)
- TFIL's scope of work: Detailed Engineering designs & drawings, supply of Geogrids, supply of Moulds for casting of Panels, Nonwoven Geotextile & Supervision of construction

Table-1 shows the property of the reinforced infill, retained fill and foundation soil taken into consideration in the designs.

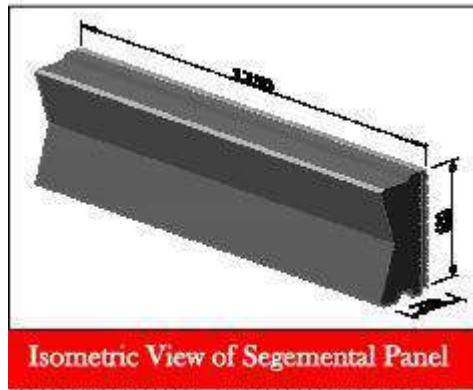

Table-1

Property/Fill	Cohesion (C) - KN/m ²	Angle of Internal Friction (φ) -	Unit Weight (γ) - KN/m ³
Reinforced Infill Soil	0	35	20
Retained Soil	0	35	20
Foundation Soil	0	30	18

The borehole and foundation soil test report showed existence of black cotton soil in the area where the RS Wall was to be constructed. Thereby experts advice was taken and multi layers of good soil were provided by excavating the black cotton soil to achieve the required safe bearing capacity that will be sufficient to withstand the bearing pressure exerted by the weight of the infill and other external loads.

The design of the walls was carried out using the BS 8006: 1995 for Static Condition & FHWANHI-00-043 for Seismic Condition, which comprised checks for external, internal and global stability under static and seismic conditions.

Construction of the wall was carried out under the supervision of TechFab India Industries Ltd.



Elevation view of RS Wall



Abutment of RS Wall



Completed Wall

Conclusion:

The project was successfully completed in August 2009.

For further details kindly contact :

TechFab India Industries Ltd.

711/712, Embassy Centre, Nariman Point, Mumbai – 400021
Tel: + 91- 22 - 2287 6224 / 6225 Fax: + 91- 22 - 2287 6218
E: info@techfabindia.com
W: www.techfabindia.com

CASE HISTORY

Rev:01, Date : 24.05.2020

STRENGTHENING AND WIDENING OF ROAD AT PALANPUR - SWAROOPGUNJ PACKAGE ON NH-14, GUJARAT GUJARAT, INDIA



RS Wall with Segmental Panel facia

Client:	Products used:
NATIONAL HIGHWAY AUTHORITY OF INDIA (NHAI)	TECHGRID KNITTED & PVC COATED POLYESTER GEOGRID WITH TENSILE STRENGTH OF 40 TO 250 KN/m
Main contractor:	NONWOVEN GEOTEXTILE
L&T ECC DIVISION, AHMEDABAD	
Manufacturer & Supplier:	Year of construction:
TECHFAB (INDIA) INDUSTRIES LTD.	NOVEMBER 2009

Project description:

L & T ECC Ltd. has awarded the work of Reinforced soil wall to M/s Techfab India Industries Ltd. The scope of work include, design of reinforced soil wall, their approval, submission of drawings, supply of moulds and supervision at site. There are approaches for ROBs, flyovers and vehicular underpass for reinforced soil work. Total stretch for the project is starts from the Palanpur in Gujarat state to Swaroopgunj in Rajasthan state, India.

Project Challenges:

Size of the panel has been selected by the client, i.e. 1.25m x 0.6m. It has been decided to use this panel with PET Geogrid with friction / tongue and groove connection. Designs must be checked for the connection strength for this type of panel-Geogrid arrangement,

Solution:

Testing has been done at IIT-Madras for the friction based connection for Techgrid-PET with this panel type. Design has been checked and verified with consideration of test results and ensured the tension in Geogrid is less than the available connection strength at particular normal pressure.



Photo 1 : Elevation view of RS wall

Salient Features of the Reinforced Soil Walls :

- Wall Facing Area: 55,349 Sqm.
- Wall Height: 10m
- Soil Reinforcement: TechGrid knitted & PVC coated polyester Geogrids with Tensile Strength of 40 to 250 KN/m
- Facing: Segmental Panel Fascia
- Design Methodology: BS 8006: 1995 (Static Condition)
FHWA-NHI-00-043 (Seismic Condition)
- TFIL's scope of work: Detail designs & drawings, supply of Geogrids, Moulds for Segmental Panels, Nonwoven Geotextile & Supervision of construction

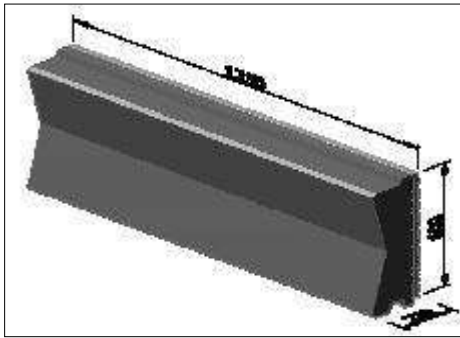

Isometric view of Segmental Panel

Property/Fill	Cohesion (C) - KN/m ²	Angle of Internal Friction (φ) -	Unit Weight (γ) - KN/m ³
Reinforced Infill Soil	0	35	20
Retained Soil	0	35	20
Foundation Soil	0	30	18

The design of the walls was carried out using the BS 8006: 1995 for Static Condition & FHWA - NHI-00-043 for Seismic Condition, which comprised checks for external, internal and global stability under static and seismic conditions. Construction of the wall was carried out under TechFab India Industries Ltd's supervision.



Photo 2 : Elevation view of RS wall



Photo 3 : Elevation view of RS wall

Conclusion:

The project was successfully completed in November 2009.

For further details kindly contact :

TechFab India Industries Ltd.

711/712, Embassy Centre, Nariman Point, Mumbai – 400021

Tel: + 91- 22 - 2287 6224 / 6225 Fax: + 91- 22 - 2287 6218

E: info@techfabindia.com

W: www.techfabindia.com

CASE HISTORY

Rev:01, Date : 01.06.2020

**FOUR LANING OF NAGPUR - HYDERABAD SECTION OF NH-7 FROM
KM. 123.000 TO 153.000, CONTRACT PACKAGE NO. NS-61, MAHARASHTRA
MAHARASHTRA, INDIA**



RS Wall with Segmental Panel facia

Client:	Products used:
NATIONAL HIGHWAYS AUTHORITY OF INDIA (NHAI)	• TECHGRID KNITTED & PVC COATED POLYESTER GEOGRID WITH TENSILE STRENGTH OF 40 TO 250 KN/m • NONWOVEN GEOTEXTILE
Main contractor:	
M/s. IDEAL ROAD BUILDERS PVT LTD., MUMBAI	
Manufacturer & Supplier:	Year of construction:
TECHFAB (INDIA) INDUSTRIES LTD.	FEBRUARY 2010

Project description:

IRB Ltd has awarded the work of Reinforced Soil Retaining Wall to M/s TechFab (India) Industries Ltd. The scope of work include, design of reinforced soil wall, their approval, submission of drawings, supply of moulds and supervision at site. The selection of panel facia is also as per the client requirement, for that newer mould has been made to have a corrugation finish at the front face.

Project Challenges:

Size of the panel has been selected by the client, i.e. 1.25m x 0.6m. It has been decided to use this panel with PET Geogrid with friction / tongue and groove connection. Designs must be checked for the connection strength for this type of panel-Geogrid arrangement.

Solution:

Testing has been done at IIT-Madras for the friction based connection for Techgrid-PET with this panel type. Design has been checked and verified with consideration of test results and ensured the tension in Geogrid is less than the available connection strength at particular normal pressure.



Photo 1 : Elevation view of Nagpur-Hyderabad Section

Salient Features of the Reinforced Soil Walls :

- Wall Facing Area: 11781 Sqm.
- Wall Height: 13.0m Maximum
- Soil Reinforcement: TechGrid knitted & PVC coated polyester Geogrids with Tensile Strength of 40 to 250 KN/m
- Facing: Segmental Panel Fascia
- Design Methodology: BS 8006: 1995 (Static Condition)
FHWA-NHI-00-043 (Seismic Condition)
- TFIL's scope of work: Detailed Engineering designs & drawings, supply of Geogrids, supply of Moulds for casting of Panels & Supervision of construction

Table-1 shows the property of the reinforced infill, retained fill and foundation soil taken into consideration in the designs.

Table-1

Property/Fill	Cohesion (C) - KN/m ²	Angle of Internal Friction (ϕ) - Degrees	Unit Weight (γ) - KN/m ³
Reinforced Infill Soil	0	34	20
Retained Soil	0	34	20
Foundation Soil	0	30	18

The design of the walls was carried out using the FHWA-NHI-00-043 guidelines and comprised checks for external, internal and global stability under static and seismic conditions. Construction of the wall was carried out under the supervision of TechFab India Industries Ltd.



Elevation view of RS wall

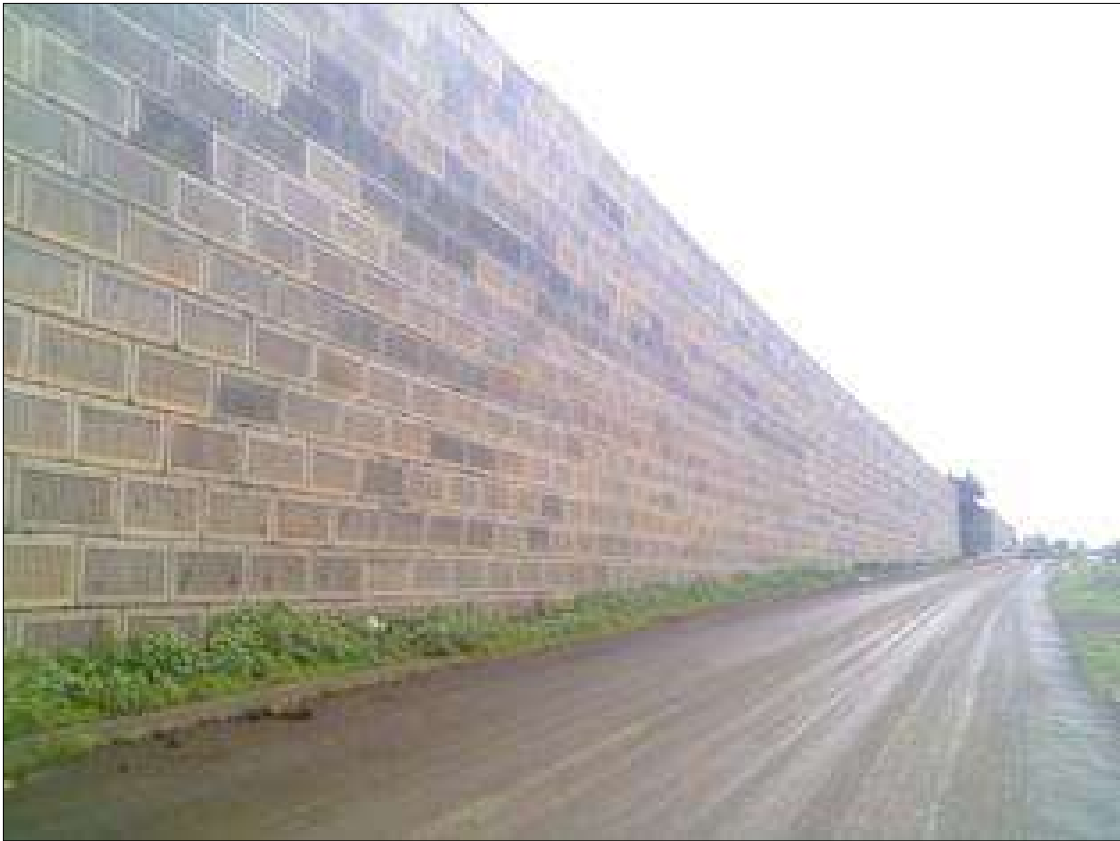

Elevation view of RS wall

Conclusion:

The project was successfully completed in February 2010.

For further details kindly contact :

TechFab India Industries Ltd.

711/712, Embassy Centre, Nariman Point, Mumbai – 400021
Tel: + 91- 22 - 2287 6224 / 6225 Fax: + 91- 22 - 2287 6218
E: info@techfabindia.com
W: www.techfabindia.com

CASE HISTORY

Rev:01, Date : 24.05.2020

CONSTRUCTION OF EIGHT LANE ACCESS CONTROLLED EXPRESSWAY AS OUTER RING ROAD TO HYDERABAD CITY, PHASE-II PEDDA AMBERPET (KM. 95.000) TO BONGULUR (KM. 108.000) , ANDHRA PRADESH
HYDERABAD, ANDHRA PRADESH, INDIA



RS Wall with Modular Block facia

Client:	Products used:
HYDERABAD URBAN DEVELOPMENT AUTHORITY	<ul style="list-style-type: none">• TECHGRID KNITTED & PVC COATED POLYESTER GEOGRID WITH TENSILE STRENGTH OF 40 TO 250 KN/m• NONWOVEN GEOTEXTILE
Main contractor:	
KMC CONSTRUCTION LIMITED	
Manufacturer & Supplier:	Year of construction:
TECHFAB (INDIA) INDUSTRIES LTD.	MARCH 2010

Project description:

Project of eight laning express Hyderabad outer ring road have been awarded to various contractors. M/s. KMC Construction Ltd. has awarded the work of reinforced soil wall facia with block as a facia and Knitted and PVC coated polyester Techgrid (TFI-Geogrid) as reinforcing member. M/s. Techfab India Industries Ltd. has give a total scope of design, drawings, their approval from Independent Consultant, Supply of block making machine and supervision at site.

Project Challenges:

Height of Reinforced soil wall is on higher side, around 15 to 17meter. Considering the soil profile bore log data, need arises to make it safe in global stability analysis.



Photo 1 : Elevation view of Two Tier RS wall

Solution:

The design of the walls was carried out using the BS-8006 / FHWA-NHI-00-043 guidelines and comprised checks for external, internal and global stability under static and seismic conditions. Considering the global stability analysis the berm has been given for the height more than 10 meter. Minimum 1meter of berm has been given for the wall height above 10 meter. Global stability checked has been performed for the two tiered wall, along with the external and internal stability checks.

Construction of the wall was carried out under the supervision of TechFab India Industries Ltd.

Salient Features of the Reinforced Soil Walls :

- Wall Facing Area: 11,500 Sqm.
- Wall Height: 17m
- Soil Reinforcement: TechGrid knitted & PVC coated polyester Geogrids with Tensile Strength of 40 to 250 KN/m
- Facing: Modular Block Facia
- Design Methodology: BS 8006: 1995 (Static Condition)
FHWA-NHI-00-043 (Seismic Condition)
- TFIL's scope of work: Detail designs & drawings, supply of Geogrids, Panels,
Nonwoven Geotextile & Supervision of construction



Photo 2 : Abutment RS wall

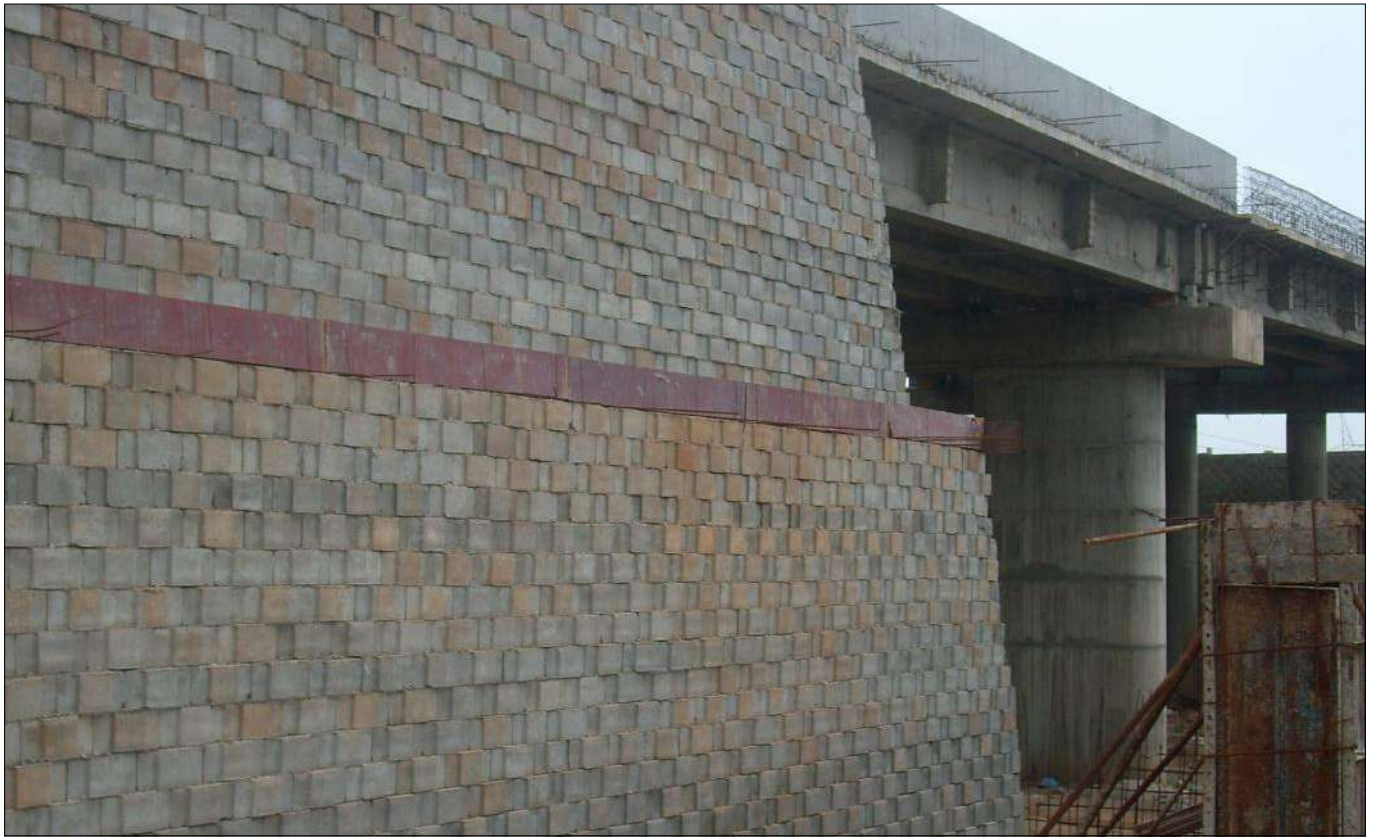

Photo 3 : Elevation view of Two Tier RS wall

Conclusion:

The project was successfully completed in March 2010.

For further details kindly contact :

TechFab India Industries Ltd.

711/712, Embassy Centre, Nariman Point, Mumbai – 400021
Tel: + 91- 22 - 2287 6224 / 6225 Fax: + 91- 22 - 2287 6218
E: info@techfabindia.com
W: www.techfabindia.com

CASE HISTORY

Rev:01, Date : 02.09.2020

CONSTRUCTION OF FLYOVER AT NANA VARCHHA ON VARCHHA ROAD IN SURAT, GUJARAT SURAT, GUJARAT, INDIA



RS Wall with Discrete Panel facia

Client:	Products used:
SURAT MUNICIPAL CORPORATION	• TECHGRID KNITTED & PVC COATED POLYESTER GEOGRID WITH TENSILE STRENGTH OF 40 TO 250 KN/m • NON WOVEN GEOTEXTILE
Main contractor:	
RAJKAMAL INFRASTRUCTURES PVT LTD.	
Consultant:	Year of construction:
S N BHOBHE & ASSOCIATES PVT LTD.	JANUARY 2008
Manufacturer & Supplier:	
TECHFAB (INDIA) INDUSTRIES LTD.	

Project description:

Surat Municipal Corporation awarded the work of construction of Flyover at Nana Varchha on Varchha Road in Surat to M/s Rajkamal Infrastructures Pvt. Ltd. TechFab India Industries Ltd was awarded with the project for providing the detail designs and drawings for the Flyover with RS Wall. The Project consisted of RS Wall on Surat Left Side (146m) & Surat Right Wall (155m) and Kamrej Left Side (179m) & Kamrej Right Wall (180.5m) and their abutments. Techfab India Industries Ltd. provided the detailed designs and drawings for the project.

Solution:

After a careful evaluation of the project requirements and the existing site conditions a geogrid reinforced soil wall with discrete panel facia was considered as the feasible solution.

TechGrid knitted and PVC coated polyester geogrids, manufactured by TechFab (India) Industries Ltd. at their state of the art ISO 9001: 2000 certified plant in Silvassa, were used as the soil reinforcement. TechGrid geogrids are manufactured from select grades of high tenacity, high molecular weight polyester yarns using an advanced weft insertion warp knitting process and coated with a specially formulated PVC plastic. The high performance characteristics of these world class geogrids enabled the walls as high as 9m to be designed safely and economically.

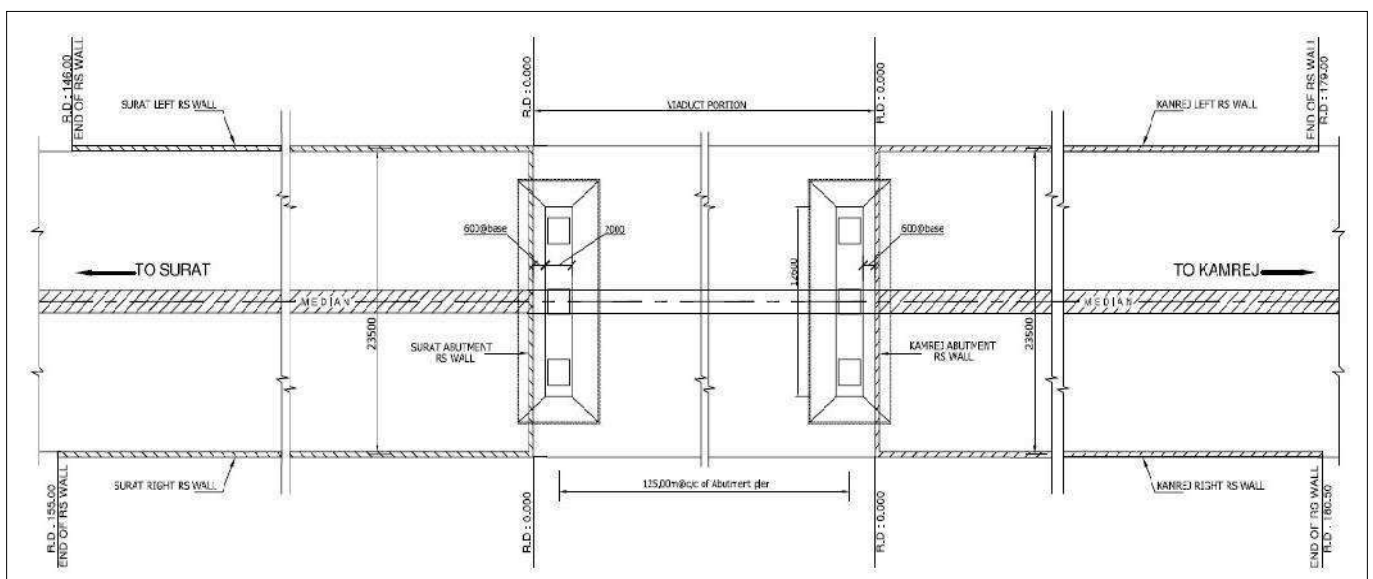

Key Plan

Salient Features of the Reinforced Soil Walls :

- Wall Facing Area: 3760 Sqm.
- Wall Height: 9m
- Soil Reinforcement: TechGrid knitted & PVC coated polyester Geogrids with Tensile Strength of 40 to 250 KN/m
- Facing: Discrete Panel Fascia
- Design Methodology: BS 8006: 1995 (Static Condition)
FHWA-NHI-00-043 (Seismic Condition)
- TFIL's scope of work: Detailed Engineering designs & drawings, supply of Geogrids, supply of Moulds for Discrete Panels, Nonwoven Geotextile & Supervision of construction

Properties considered in the design of the RS Wall are shown in Table-1.

The fascia type used was a discrete panel type of size 1.48m x 1.48m x 0.18m. Due to the shape and size of the panel it was able to absorb differential settlement of magnitude significantly higher than other panel types.

Table-1

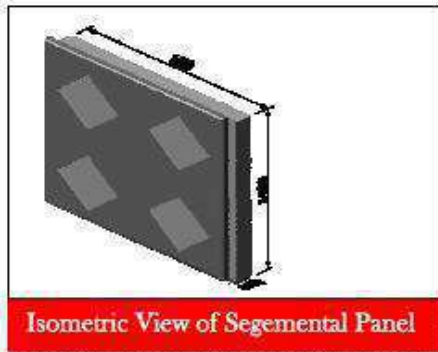

Property/Fill	Cohesion (C) - KN/m ²	Angle of Internal Friction (φ) - Degrees	Unit Weight (γ) - KN/m ³
Reinforced Infill Soil	0	32	20
Retained Soil	0	32	20
Foundation Soil	0	30	18

The borehole and foundation soil test report showed very low friction angle and high cohesion. So in designing the RS wall it was considered that after excavation of 2.25m foundation depth the foundation soil was again excavated for 500mm depth and replaced with compacted fill according the approved quality. Therefore the total depth of excavation at the site was taken as 2.75m from existing service road level. Also, the unsuitable soils were removed and replaced with compacted fill of approved quality where it is required.

The design of the walls was carried out using the BS 8006: 1995 for Static Condition & FHWA-NHI-00-043 for Seismic Condition, which comprised checks for external, internal and global stability under static and seismic conditions.

Construction of the wall was carried out under the supervision of TechFab india Industries Ltd's supervision.



Elevation view of RS wall



Elevation view of RS wall

Conclusion:

The project was successfully completed in Jan 2008.

For further details kindly contact :

TechFab India Industries Ltd.

711/712, Embassy Centre, Nariman Point, Mumbai – 400021
Tel: + 91- 22 - 2287 6224 / 6225 Fax: + 91- 22 - 2287 6218
E: info@techfabindia.com
W: www.techfabindia.com

CASE HISTORY

Rev:01, Date : 14.05.2020

REINFORCED SOIL WALLS AND SLOPE PROTECTION MEASURES AT STATUE OF UNITY, GUJARAT

GUJARAT, INDIA



RS Wall & Slope Protection

Client:	Products used:
SARDAR SAROVAR NARMADA NIGAM LIMITED	<ul style="list-style-type: none">• TECHFAB METAL GABION MATTRESS - ZINC+PVC COATED• TECHGRID BIAXIAL GEOGRID - HIGH STRENGTH BIAXIAL GEOGRID• TECHGRID UNIAXIAL GEOGRID - VARIOUS GRADES OF UNIAXIAL GEOGRID• TECHGEO PR SERIES - NONWOVEN POLYPROPYLENE GEOTEXTILE
Main contractor:	
L&T CONSTRUCTION, BUILDINGS & FACTORIES	
Manufacturer & Supplier:	
TECHFAB (INDIA) INDUSTRIES LTD.	
Year of construction:	
2019	

Project Description:

The Statue of Unity, the dream project of the honourable Prime Minister of India, is a colossal statue of 'The Iron Man of India', Sardar Vallabhbhai Patel. It is the world's tallest statue with a height of 182 metres and is located on a river island facing the Sardar Sarovar Dam on the river Narmada in Kevadiya colony, Gujarat.

Techfab India Industries Ltd. is proud to participate in the making of history – as a Technology Provider and Supplier of Techgrid Geogrid & TechFab Metal Gabion Mattress for the project. The statue was inaugurated by honourable Prime Minister of India on 31st October 2018, the 143rd anniversary of Vallabhbhai Patel's birth.

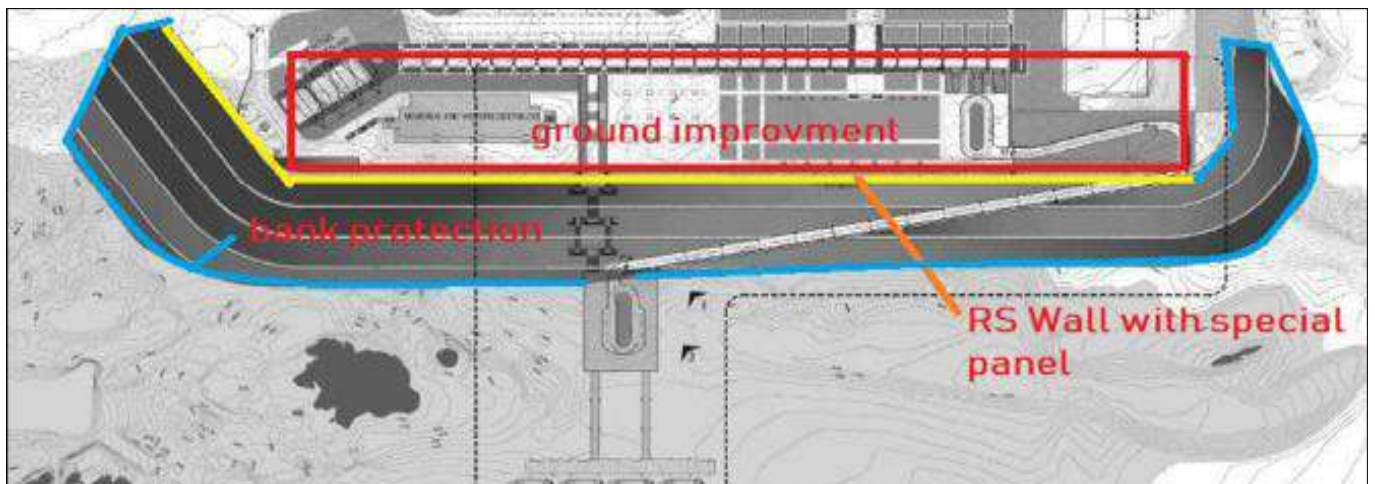

Areas of Applications:

- A. Slope Protection works
- B. Ground Improvement Works
- C. Reinforced Soil Wall Works

A. Slope Protection Works

- Memorial and Visitors Centre (M&VC Area) is located on nearest river bank side. The 'platform' for M&VC structures and other amenities including large landscape works was created on top of river bank with the help of gentle and stable slope from the river bed level.
- The level of M&VC base / platform was kept above HFL. The ramp may come in submerged condition when the water is discharged from dam. Hence, it is susceptible to erosion at large scale considering the proximity of the dam and the discharge caring capacity of the river.
- In order to protect the ramp, slope protection works consisting of TechFab Metal Gabion Mattress along with Techgeo Nonwoven Geotextile were proposed and adopted.
- TechFab Metal Gabion Mattress, (10x12, 2.7mm/3.7mm wire ϕ , Zinc+PVC Coated) of 1.0m thickness were used on the ramp having slope 1:2 with few intermediate berms.
- Techgeo nonwoven geotextiles are manufactured from high quality polypropylene staple fibres for durability. It is used for separation, filtration & drainage function below TechFab Metal Gabion Mattress.
- Project specific construction methodology was prepared and submitted in addition to detailed drawings for the proper execution and performance of the system.

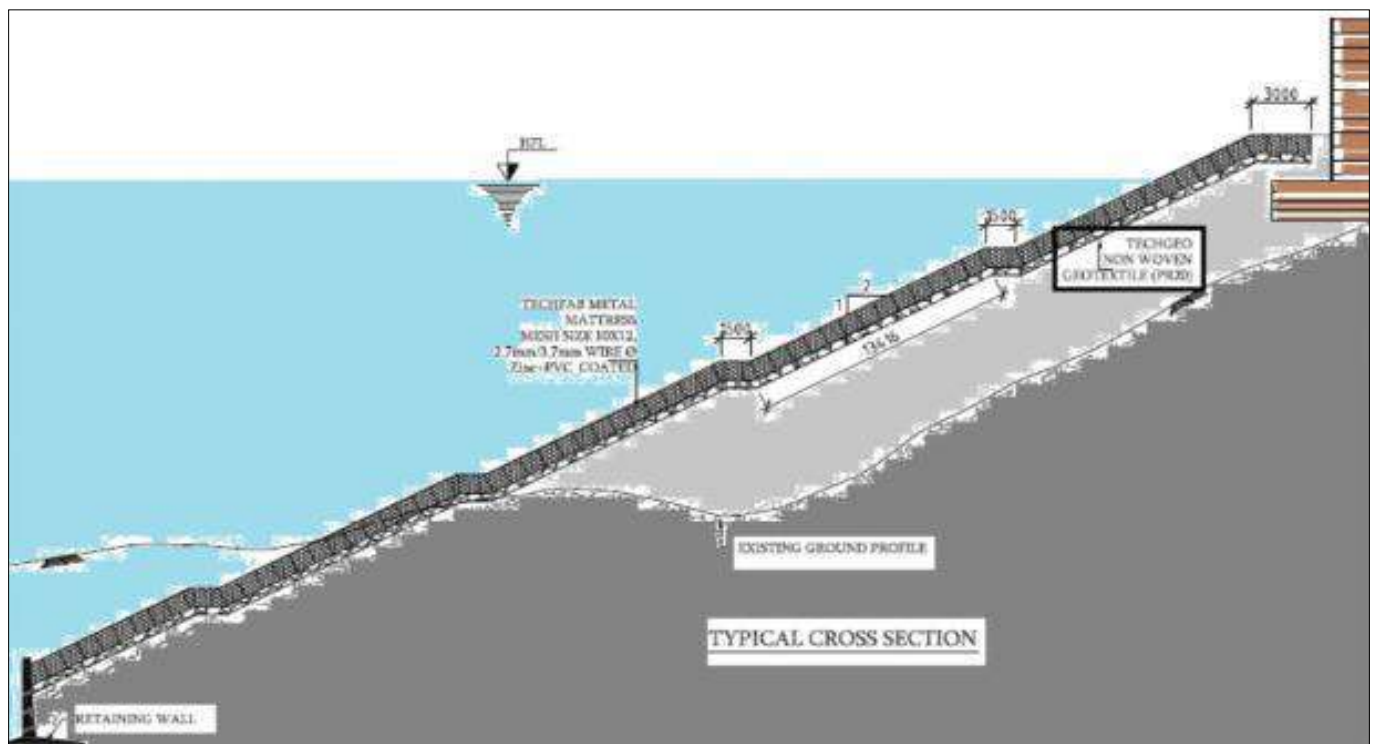

Typical section illustrating the application of TechFab Metal Gabion Mattress on Ramp

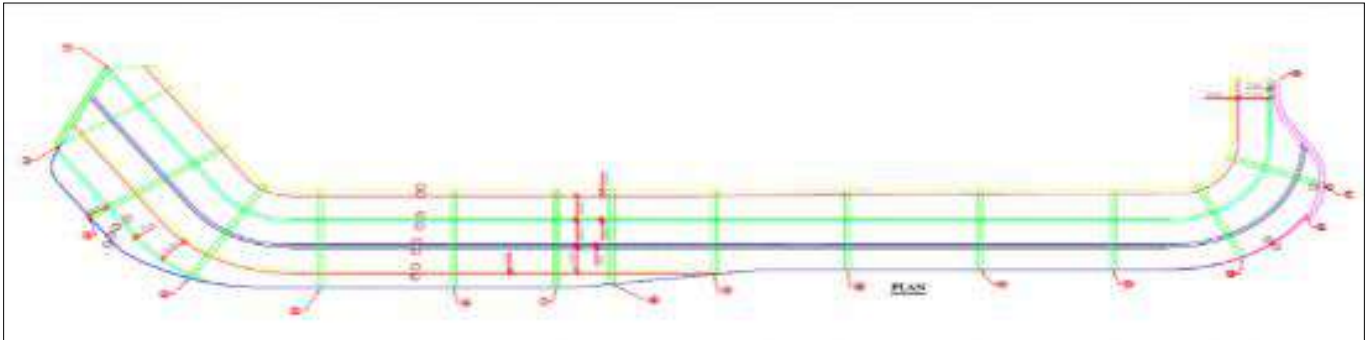

Plan details illustrating the application area of TechFab Metal Gabion Mattress



TechFab Metal Gabion Mattress laying in progress



TechFab Metal Gabion Mattress - Panoramic View

B. Ground Improvement Works

- The Memorial and Visitors Centre and other structures are to be built on reinforced soil walls all around the area. The reinforced soil walls were positions mostly over 'filled up' space created along with stable ramp. Hence, ground improvement was warranted.
- The ramp was created by compacting the soil in number of layers to ensure proper stiffness of the sloped area. Although, to minimize settlement, layers of Techgrid geogrid are considered as subgrade stabilization.
- Ground improvement in the form of three layers of Techgrid Biaxial Geogrid was proposed. TechGrid Biaxial series comprise biaxial geogrids manufactured from select grades of high tenacity, high molecular weight, and low carboxyl end group polyester yarn to ensure high strength, low creep and excellent durability.
- The three layers were laid with 500mm vertical spacing between each layer and were extended 3.0m and 5.0m in front and back respectively beyond the design reinforcement length of the reinforcement soil walls to be built over the area.

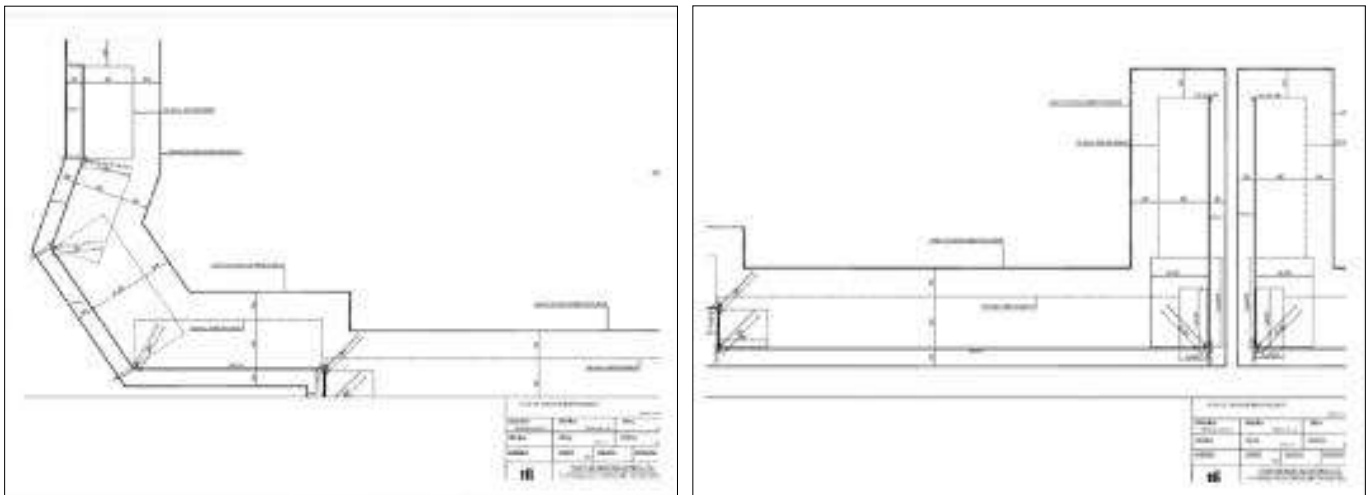

Plan Drawings for Ground Improvement with TechGrid Geogrid



Laying of TechGrid Geogrid in Progress



Marking in progress for RS Walls



Geogrid Laying for RS Walls



Finished view of RS Wall Panels



L&T Construction Building & Infra. STATUE OF UNITY PROJECT, GUJARAT. **UNITY**

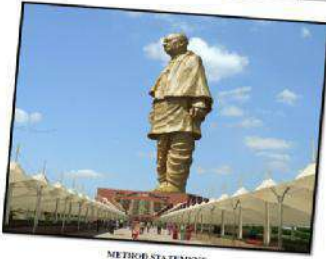

METHOD STATEMENT FOR RSW PANEL ERECTION WORKS TFEUW-9471

Rev No.	Date	Description	Prepared (Author)	Checked	Reviewed (QA/QC)	Approve
01	20.04.2017	Method statement for RSW Panel Erection	PS		PS	MSR

UNITY The Statue of Unity Project, Gujarat TFEUW-9471 Rev: 01 1

L&T Construction Building & Infra. STATUE OF UNITY PROJECT, GUJARAT. **UNITY**



METHOD STATEMENT OF GABION MATTRESSES FOR SLOPE PROTECTION TFEUW-9471

Rev No.	Date	Description	Prepared (Author)	Checked	Reviewed (QA/QC)	Approve
01	04.04.2017	Method statement for Gabion Mattress	PS		MSR	MSR

UNITY The Statue of Unity Project, Gujarat TFEUW-9471 Rev: 00 1

Project specific Construction Methodology for Reinforced Soil Walls and Gabion Mattress Installation



Panoramic View of TechFab products in the vicinity of Sardar Sarovar Dam



Panoramic View of TechFab products in the vicinity of Sardar Sarovar Dam

For further details kindly contact :

TechFab India Industries Ltd.

711/712, Embassy Centre, Nariman Point, Mumbai – 400021

Tel: + 91– 22 - 2287 6224 / 6225 Fax: + 91– 22 - 2287 6218

E: info@techfabindia.com

W: www.techfabindia.com

CASE HISTORY

Rev:01, Date : 22.06.2020

**REINFORCED SOIL WALL FOR MONSOON PALACE AT AAMBY VALLEY,
LONAVALA, MAHARASHTRA**
LONAVALA, MAHARASHTRA, INDIA



Earth Retention

Client:	Products used & Quantity supplied:
ANJUM G.BILAKHIA	TECHGRID UNIAXIAL GEOGRID TGU
Main contractor:	(KNITTED & POLYMER COATED POLYESTER GEOGRID
SPECTRUM ENGINEERS, VADODARA	WITH CE MARK, BBA CERTIFICATION & IRC APPROVED)
Manufacturer & Supplier:	Year of construction:
TECHFAB (INDIA) INDUSTRIES LTD.	MARCH 2012

Salient Features of the Project :

Facing Area : 4500.00 Sqm
Length of Stretch : 300.0 m

Project description & Challenges:

Monsoon Palace is being built by Mr. Anjum G. Bilakhia at Half Acre Area, Village-Devgar, Taluka-Mulshi, North Lake at Aamby Valley City, Lonawala, District -Pune.

The Palace is surrounded by hilly terrain and running streams. Due to high embankments and steep slopes of basically murrum soil, it was necessary to have a retaining wall for reinstatement purposes. Since these walls were outer walls surrounding the monsoon palace, the client and architect was willing to have an aesthetic and viable solution compared to the conventional solution of RCC wall.

Reinforced Soil Wall provides an aesthetic as well as an economical solution for the retention of earth / slopes as compared to the conventional RCC Wall. Reinforced Soil Wall can accommodate differential settlement which RCC wall can't withstand and gets distressed with cracks.

With consideration to the techno-economics of the project, the client / architect decided to award the project to TechFab India Industries Ltd.



During Construction

Solution:

TechFab (India) Industries Ltd suggested the use of TechGrid Uniaxial Geogrid TGU of Ultimate Tensile Strength varying from 40 KN/m to 250 KN/m. These Polyester Uniaxial Knitted Geogrids are used as primary reinforcements to the existing steep slopes. Geomembrane was provided below the top drain to prevent any ingress of precipitation or runoff water. Design of Reinforced Soil Wall was done by considering the maximum possible vehicular load and other surcharge loads as per the IRC. ReSSA 3.0 Software was used to carry out the Global Stability Check for the designed Reinforced Soil Wall.

By giving this solution of Reinforced Soil Wall, client has developed extra land of around 2 acres.

TechGrid Geogrid TGU Series are manufactured from superior grades of polyester filament yarn with high tenacity, high tensile modulus, low creep and low shrinkage. TGU Series are Uniaxial Geogrids with high strength in the machine direction and are suitable for soil reinforcement applications requiring strength primarily in one direction. Products are available with machine direction strengths ranging from 40 KN/m to 250 KN/m.

Yarns with high molecular weight ($> 25,000$) and low carboxyl end groups (< 30) are used to ensure durability of the Geogrids used in permanent structures. The knitted grid is then given high quality polymeric coating using a specially formulated PVC compound. The coating completely saturates and envelopes the polyester yarn bundles forming a protective cover enhancing – dimensional stability of the Geogrid, resistance to installation damage and protection from the environment



During Construction

TechGrid Geogrid TGU Series for Soil Reinforcement :

Inclusion of TechGrid Geogrid TGU Series transforms a compacted fill into a coherent composite material. When the soil strains in response to applied loads, tensile forces are generated in the Geogrid because of the excellent interaction between the Geogrid and soil. The tensile forces developed in the reinforcement keeps the reinforced soil mass in stable equilibrium.

Long-term Design Strength

Design of the Geogrid reinforcement is based on the long-term design strength, i.e. the minimum assured strength of the reinforcement at the end of the design life of the structure.

The long-term design strength (TD) is calculated as follows:

$$TD = \frac{T_{ult}}{RF_{cr} RF_{id} RF_d}$$

Where:

T_{ult} = Peak ultimate tensile strength (MARV) as per ASTM D 6637

RF_{cr} = Reduction factor for creep;

RF_{id} = Reduction factor for installation damage

RF_d = Reduction factor for durability

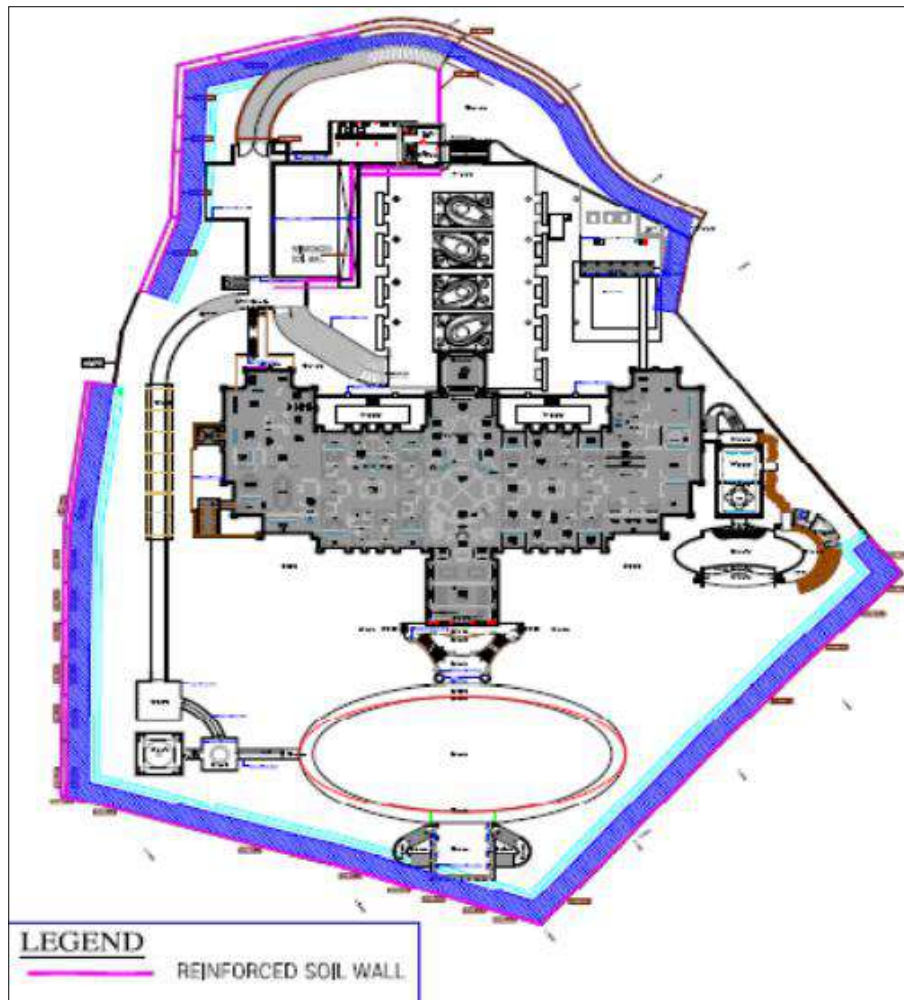

Plan showing location of Reinforced Soil Wall

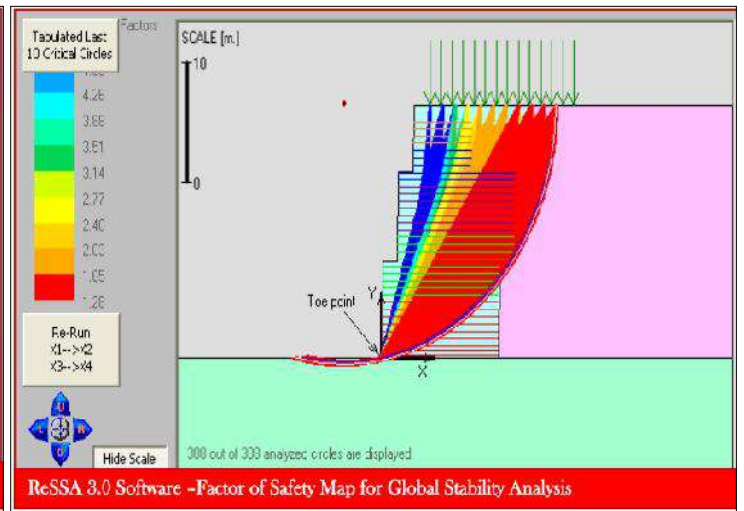
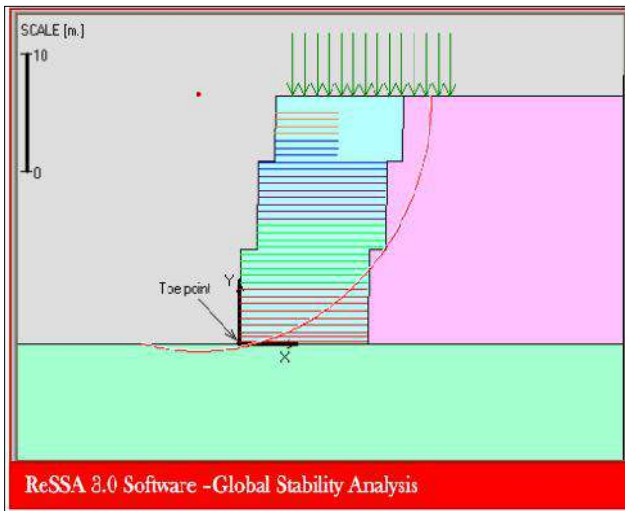

Design Analysis Report

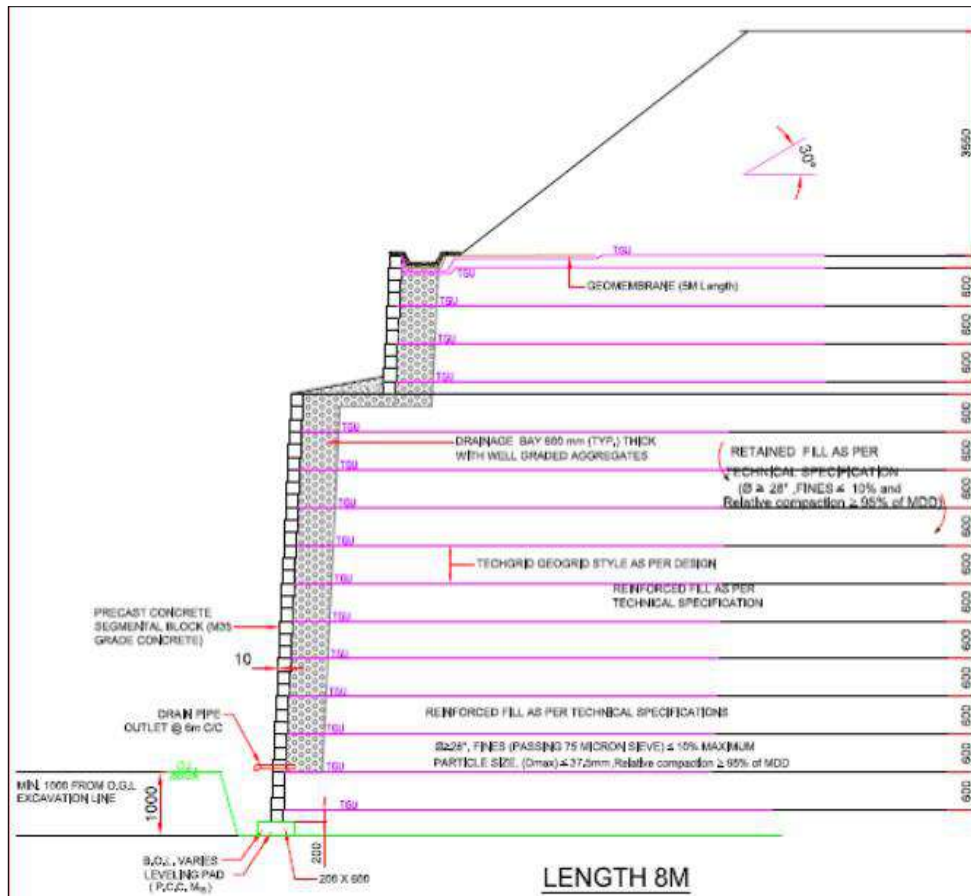

Typical Cross Section Drawing

Design, drawings and the use of TechFab India Industries Ltd's TechGrid Uniaxial Geogrid TGU for Reinforcement of existing steep slopes were approved in principle by the Client / Architect of the project.

Execution:

Based on the approval given by the Client / Architect for the suitability of the design and drawings as given by TechFab India Industries Ltd, the execution work was awarded to the contractor M/s. Spectrum Engineers. Modular Blocks were used as fascia to support the reinforced / back fill. Since modular blocks are relatively smaller in size, they are easy to cast and are able to follow the curve profile as and when required. The execution was carried out stage wise as per the design and drawings furnished by TechFab India Industries Ltd.

Applications of TechGrid TGU:

- Reinforced Soil Retaining Walls
- Steep Slopes

Benefits of TechGrid TGU:

- Used as reinforcing medium.
- High Tensile Strength ranging from 40 KN/m to 250 KN/m
- Low creep and low shrinkage
- Highly durable & resistant to acids & alkalis present in soil

Conclusion :

The project was successfully completed in March 2012.

For further details kindly contact :

TechFab India Industries Ltd.

711/712, Embassy Centre, Nariman Point, Mumbai – 400021

Tel: + 91– 22 - 2287 6224 / 6225 Fax: + 91– 22 - 2287 6218

E: info@techfabindia.com

W: www.techfabindia.com

CASE HISTORY

Rev:01, Date : 22.05.2020

REINFORCED SOIL WALL FOR BUNGALOW VILLA PREMISES, LONAVALA, MAHARASHTRA LONAVALA, MAHARASHTRA, INDIA



Earth Retention

Client:	Products used & Quantity supplied:
	TECHGRID GEOGRID
Main contractor:	TECHGEO NONWOVEN GEOTEXTILE
	TECHFAB METAL GABIONS & WELD MESH
Manufacturer & Supplier:	Year of construction:
TECHFAB (INDIA) INDUSTRIES LTD.	2013

Project description:

There is a construction of a hill top villa at Kumne village Lonavala with an interest of application of geosynthetics to their property which has natural mountain terrain, mark able elevated plinth to existing road level, heavy precipitation and deep valley at rare end side, with touch of natural green aesthetic and state of the art design & architecture.

The reinforced soil wall & Gabion retaining wall has been proposed to slope elevated terrain in concurrence to consultant & architect. Their joint views has taken into many revisions before arriving at practicable solution which encircles the entrance front view with open patio cum parking having staircase and jogging lawn promenade as a final outcome at rare deep valley portion.

Keeping the above perspective, the scope work of Techfab India Industries Ltd., was to meet:

- Detailed engineering of reinforced soil walls & Gabion retaining walls, including design, material specification, engineering drawing and construction methodology;
- Supply of Techgrid Geogrids, Metal gabion, Geo-bags, Nonwoven Geo textile;
- Supervision of Construction.

Project challenges :

- The Entrance front Weld mesh wall (RSW) to be design in staircase form (New dimension to RS Wall);
- Protect the differential level of natural terrain height ranging from 2m to 11 m;
- To prepare design with parameters of fill ,stone etc., as per locally available resources;
- To consider The dead, Live moving Loading in conjunction to seismic activity ;
- To create lush green aesthetic touch to the property as per naturally existing area.

Solution :

After identifying best technically feasible solutions in line to project requirement and site conditions a Techgrid - Geogrid reinforced soil wall with steel wire mesh (Weld Mesh) facing is provided to accommodate staircase within the facing, at the entrance front. PVC coated galvanised Metal gabion wall with nailing, at deep valley portion was finalized, as the solution.



RSW with Weld Mesh - Under Construction



RSW with Weld Mesh - Staircase Completed



Techfab Metal Gabion Wall – Top View



Techfab Metal Gabion Wall - Completed

Salient Features of the Reinforced Soil Walls :

- Wall Height & Length : Height is 2m to 11m, total 120m length
- Soil Reinforcement: : TechGrid Geogrid
- Facing: : Weld Meshes (Steel Mesh) as front facing for RSW. Techfab Metal Gabion, TechGeo Nonwoven Geotextile bags inside the weld mesh
- Design Methodology : BS 8006 & FHWA Guidelines for RSW
- Techfab India Scope : Detailed design & drawing, supply of Geogrids, Metal Gabion, Nonwoven Geotextile & Geotextile bags & supervision of construction



RSW with Weld Mesh - Entrance

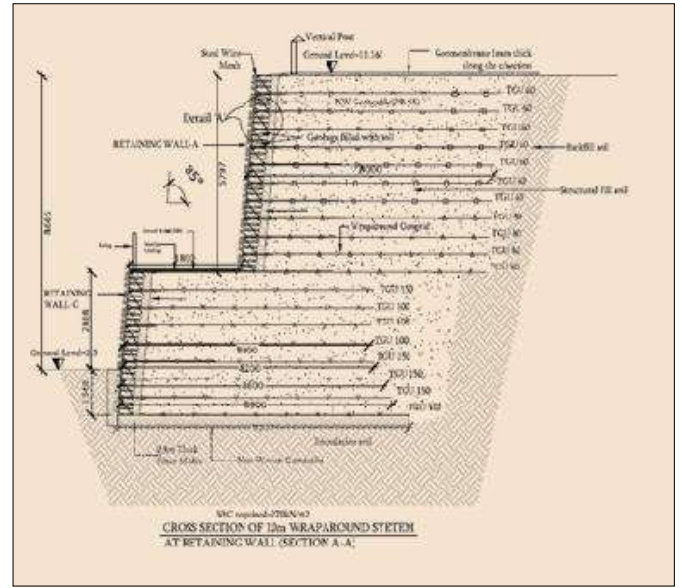

RSW with Weld Mesh - Typical Cross Section



Techfab Metal Gabion Wall - Valley Portion

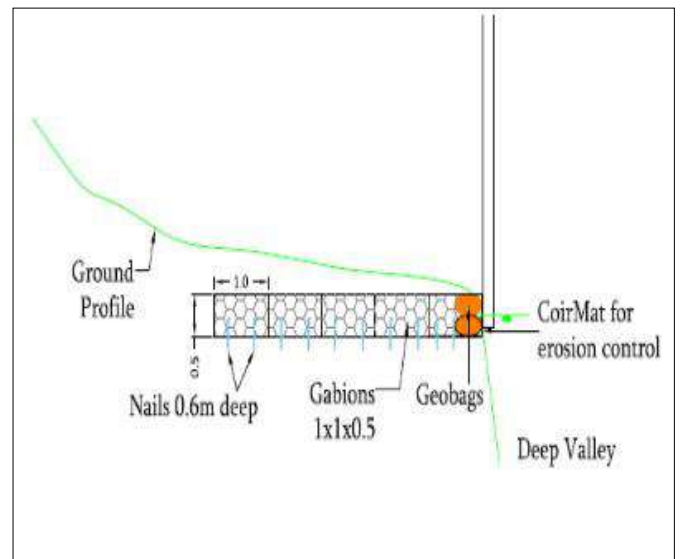

Techfab Metal Gabion Wall - Typical Design Consideration

The supplied materials, Techgrid - Geogrid, Geotextile bags and PVC coated galvanized gabions are the in house manufactured products of Techfab India Ltd., in their state of the ISO 9001:2000 certified factory under the proven and tested qualified experienced faculties having edge of national globally accredited QTP & QTC.



After Completion of Project with full vegetation

Conclusion :

The Project was successfully completed.

For further details kindly contact :

TechFab India Industries Ltd.

711/712, Embassy Centre, Nariman Point, Mumbai – 400021

Tel: + 91– 22 - 2287 6224 / 6225 Fax: + 91– 22 - 2287 6218

E: info@techfabindia.com

W: www.techfabindia.com

CASE HISTORY

Rev:01, Date : 22.05.2020

REINFORCED SOIL WALL FOR A PRIVATE BUNGALOW IN AAMBY-VALLEY LONAVALA, MAHARASHTRA

LONAVALA, MAHARASHTRA, INDIA



Earth Retention

Client:	Products used & Quantity supplied:
R K GUPTA	TECHGRID GEOGRID MODULAR BLOCK
Main contractor:	
BEST GEOSYNTHETICS PVT LTD.	Year of construction:
Manufacturer & Supplier:	
TECHFAB (INDIA) INDUSTRIES LTD.	

Project description & Challenges:

Aamby valley is a meticulously planned city with world-class infrastructure and facilities, offering everything one needs for premium living. The client bungalow was situated on a steep slope of around 70 to 80 degrees of height around 16m as seen from Fig 6. The problem the client was facing was the same as most of the owners in Aamby Valley do. Scouring was acute at some places which led to the collapse of soil wedges, further leading to slope stability failure. Rains in Aamby valley are also very heavy. The type of soil there is of lateritic and basaltic origin, it acts like a hard rock in summer and flows with rain during rains. During monsoon the situation would worsen up again. A long-term solution was what the client was requiring.



Fig 1 : During Construction

Solution:

Due to the steep slope and the uncertain behavior of the soil, our client wanted to construct a reinforced soil wall, which would not only reinforce and stabilize the slope but also provide the client with a permanent hard and stable fascia. Here blocks were used as fascia panels and for reinforcement TechGrid TGU was used. The range of TechGrid TGU used varied as per the design requirements. TechGrid was used as it is highly durable and resistant to acids & alkalis, which are present in soil.

The height to be protected also was very high and a single whole stretch wall was not a safe solution, a berm of 6m was provided after a height of 6m. After which the remaining height of 10m height was constructed. The client did not face space restriction, which became a boon for us.

The main attraction as noted from Fig 3 is the stairs which were constructed on the wall, wherein the TechGrid was not disturbed and was laid as per design criteria.



Fig 2 : Stairs over reinforcement



Fig 3 : During Construction



Fig 4 : After Construction of stairs



Fig 5 : After Construction - View from far



Fig 6 : Structure after Construction

Conclusion :

Client was very much contented with the - On time completion and the perfection of the structure. This project has come out very well and has also withstood rains. Nevertheless the structure is functioning as per the expectations.

For further details kindly contact :

TechFab India Industries Ltd.

711/712, Embassy Centre, Nariman Point, Mumbai – 400021

Tel: + 91– 22 - 2287 6224 / 6225 Fax: + 91– 22 - 2287 6218

E: info@techfabindia.com

W: www.techfabindia.com

CASE HISTORY

Rev:00, Date : 25.05.2022

ROCKFALL PROTECTION WORKS NEAR THE ROAD ADJACENT TO BIO-DIVERSITY PARK, HITECH CITY, HYDERABAD OF TSIIC CYBERABAD ZONE IN THE STATE OF TELANGANA

CYBERABAD, TELANGANA, INDIA



At the Heart of GeoHazard Mitigation Activity

Rockfall Protection

Client:	Products used :
TELANGANA STATE INDUSTRIAL INFRASTRUCTURE CORPORATION LIMITED (TSIIC)	<ul style="list-style-type: none">• DOUBLE TWISTED WIRE MESH• TECHRHOMBUS HRC• TECHFAB METAL GABION
Main contractor:	
SARATH CHANDRA CONSTRUCTION	
Manufacturer & Supplier:	Year of construction:
TECHFAB (INDIA) INDUSTRIES LTD.	2021 - 2022

Project brief:

Madhapur of Cyberabad Zone of TSIIC, a part of Hyderabad Knowledge City which falls under Industrial Area Local Authority has grown phenomenally in the last few years with many new offices / buildings coming up thereat. Many more buildings are under different stages of completion with noteworthy T-Hub's iconic building (T-Hub - a Government of Telangana's initiative for fostering innovation ecosystem) under advanced stage of completion. To meet the fast increasing demand of better connectivity for the increased traffic, Telangana State Industrial Infrastructure Corporation Limited (TSIIC) has recently constructed a new carriageway of around 850 meter connecting internal roads of Hyderabad Knowledge City with the Old Mumbai Highway joining the same adjacent to Bio-diversity Park.

This new road was constructed by drilling the hillock thereat to create a passage for the road. Now, to mitigate the hazard for the carriageway users from loose boulders on the hilltop and rock slope falling on to the carriageway, TSIIC has decided to take up slope stability and safety works.

Solution:

To reduce the risk of falling rocks on to the newly constructed Carriageway, TSIIC appointed IIT, Hyderabad to finalize a suitable scheme. TechFab India suggested a solution for Rockfall Protection & GeoHazard Mitigation based on the recommendation of IRC Highway Research Board Special Report 23 on 'State of the Art: Design and construction of rockfall mitigation systems' which was finally adopted.

The solution consisted of rock bolting, rockfall netting, and cable wire rope at edges, top, bottom, and diagonals . This solution was provided at all locations except the severe areas with overhangs. Only for the severe areas with overhangs, rock bolting, rockfall netting, and rhomboidal wire rope panels have been provided. A Rockfall Protection Embankment also provided at the toe of the slope. The rockfall protection embankment consists of a 3m high toe gabion wall with a vertical face towards the road and a trapezoidal section towards the cutting. This trench formed by the trapezoidal section towards the slope cutting also act as a rock trap ditch for any debris that may slide along the nettings.



Site before Construction

Product Description:

• **Double Twisted Wire Mesh**



TechFab India double twist (DT) mesh is available in a variety of strengths and corrosion protection coatings to suit project requirements.

For this project we have used Double Twisted Hexagonal Wire Mesh, 3mm wire dia, Mesh type 8x10, Zinc+Aluminium (Galfan) + PVC coated, with 12mm edge, diagonal, bottom and top ropes. This type of netting has high mechanical resistance required to prevent the danger of sudden rock shock loads and dissipate rock fall energy created from loose fractured rock. Since the double-twist, hexagonal-woven mesh does not unravel when some wires break.

• **TechRhombus Flexible Rope Net System**



TechRhombus high tensile rope net system is made out of high tensile steel wire ropes with tensile strength of more than 1960 N/mm². High Tensile rope net system works in combination with or without bearing plates and other elements like top & bottom support ropes, wire rope anchors and soil nails.

For this project we have used TechRhombus HRC Type (High Resistance Clip) wire rope net with rope dia. 10mm and mesh size 300mm x 300mm.

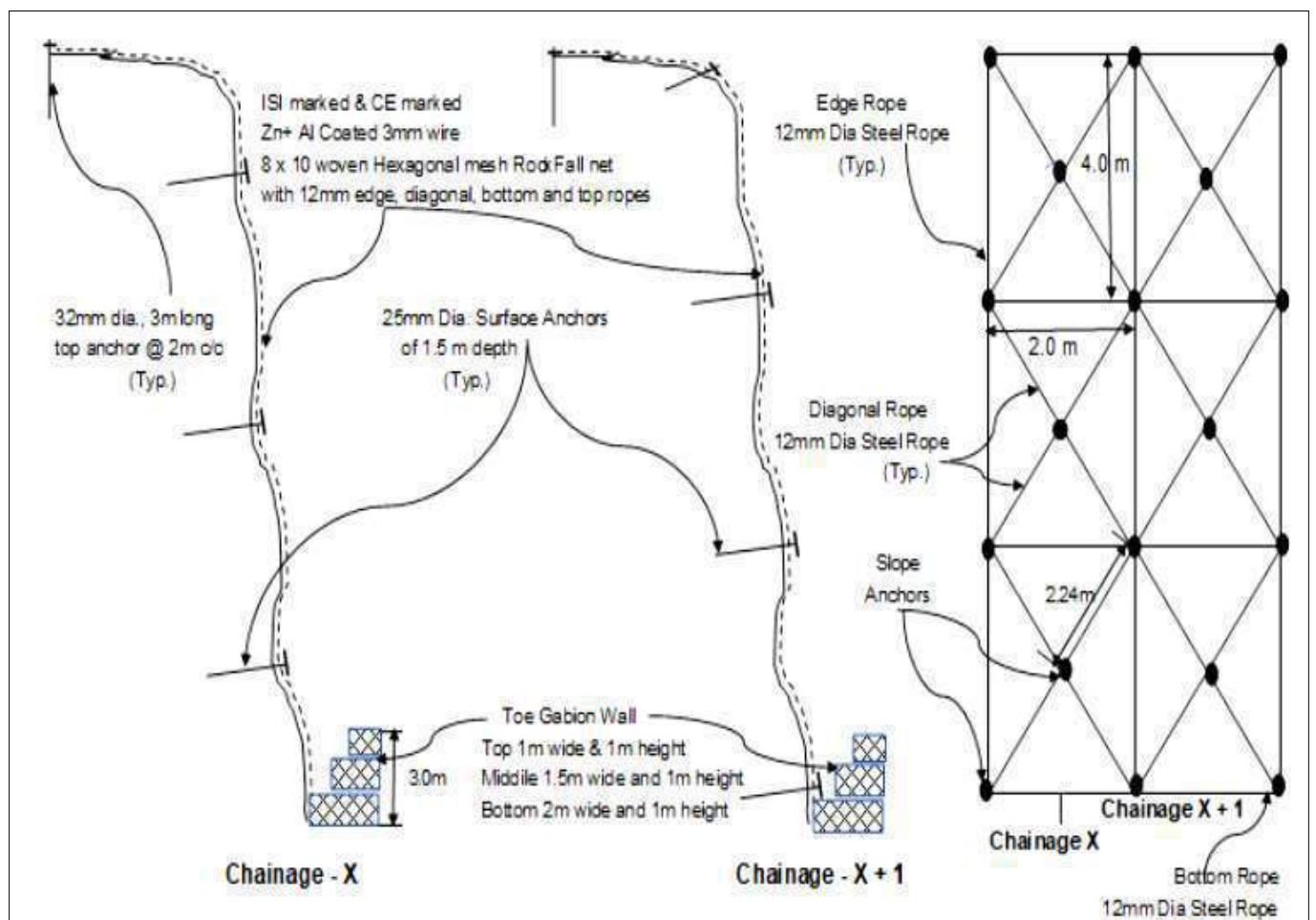

Typical Cross Sectional View & Elevation View of the proposed solution

Drone survey was carried out at the site initially by IITH, Hyderabad and Geology Professors from Hyderabad Centra University visited the location and made observations on the geology of the area. The heights were in the range of 35m to 50 m. Surficial instabilities near the face of the slope were evident from the field observations for which treatment is required to be provided. Slope stability analysis was carried out by IITH, Hyderabad using 'Geostudio' software based on the survey and geology reports and no deep-seated global stability problems were seen in the subject area.

The work started with preparatory works of taking down the loose material from hill slope side and removing by suitable methods the large boulders, bushes, shrubs, roots, grass etc., on the top of the slope and at the edge of slope. A proper medium has been created for release of pore water pressure developed due to water trapped inside the slope so as to ensure all trapped water is released.

On the prepared surface, the rockfall netting was installed which shall provide stability against any local failures that may happen between the installed rock bolts. Rockfall netting shall comprise double-twisted wire mesh with top, bottom, edge, and diagonal rope. The double-twisted wire mesh with the rope cable at edges and diagonals work as a composite that shall effectively contain smaller and medium size particles on the slope surface. The rhomboidal wire rope panels effectively take up load coming from any big-sized boulders. The depth of the rock bolts for the overhang portions were fixed at 7m.

The rock bolt on the slope surface made of Fe 500 grade steel of 25mm diameter and up to a depth of 1.5metre along with the rockfall netting. The rock bolt have a tensile capacity of 220 kN. The spacing of the rock bolts required is 4.0m c/c in vertical direction and 1.0m c/c in horizontal direction. The location of the rock bolts at 1.0m in horizontal direction should be such that the diagonals connecting the rock bolts from every 2.0m horizontal interval pass through the rock bolts at 1.0m. The rock bolts stitch the surface rock to the stable rock mass behind.



Installation works in progress

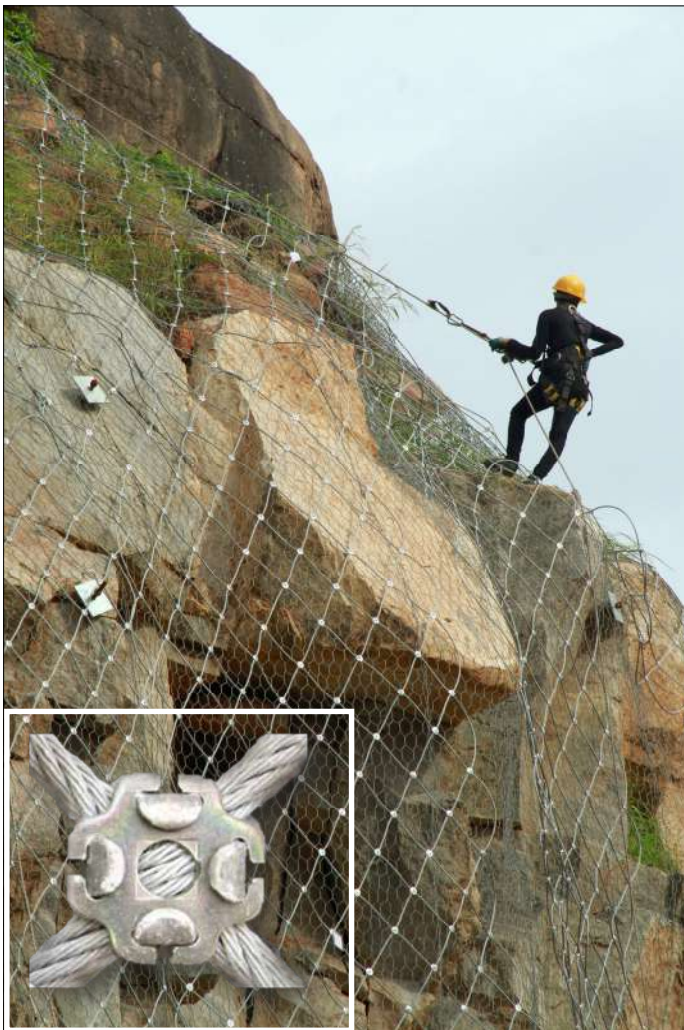

Installation works in progress



During Construction Photographs (Installation of TechRhombus)



Completed Structure

Conclusion:

The project is completed successfully.

For further details kindly contact :

TechFab India Industries Ltd.

711/712, Embassy Centre, Nariman Point, Mumbai - 400021

Tel: + 91- 22 - 2287 6224 / 6225 Fax: + 91- 22 - 2287 6218

Email : info@techfabindia.com

Website : www.techfabindia.com

CASE HISTORY

Rev:00, Date : 20.11.2020

ROCKFALL PROTECTION WORK AT JORABAT - SHILLONG SECTION OF NH-40 FROM KM. 0+000 TO KM. 61+800, ASSAM & MEGHALAYA

ASSAM & MEGHALAYA, INDIA



Rockfall Protection

Client:	Products used & Quantity supplied:
IL&FS	TECHFAB ROCKFALL NETTING, WITH SPECIAL 5.5 TWIST, ZN+PVC COATED WIRE MESH WITH MESH TYPE (8X10) - 45000 SQM.
Main Contractor:	
M/S. RAMKEY INFRASTRUCTURE LIMITED	
Manufacturer & Supplier:	Year of construction:
TECHFAB (INDIA) INDUSTRIES LTD.	2013

Project description:

The Jorabat Shillong Expressway Limited (JSEL), Guwahati has been entrusted four laning & development of Jorabat – Shillong section by NHAI. The challenge was to convert an existing 2-lane highway into a four-lane expressway in the terrain that is hilly and dense. The region also receives the highest rainfall and part of the highway is among the wettest regions in the country.

Before giving solution, consultant visited the site. It was observed that the particular section was in cutting and the cutting has exposed rock faces that were intact in some locations and fragmented in few locations. The exposed rock surface on the sloping face is always subjected to disintegration by various causes such as plant action, thermal expansion, wind, freeze and thawing action of the pore water, hydrostatic pressures etc. The disintegration of parent rock leads to formation of rock pieces, boulders and debris and they easily detach from the bed rock and will slide over the slope. Such fall of rock happens catastrophically at random locations without giving prior warning. During monsoon seasons, the situation gets worsen that rock falls may become vary frequent. This called for rockfall protection solutions.



Before implementation of Rockfall Netting

Solution:

To prevent the rockfall from the side hill slopes on to the road, TechFab india suggested Rockfall Netting with special 5.5 Twisted Zinc + PVC coated wire mesh with Mesh type (8x10) along the slope and it was anchored by using raised anchorage system at top and bottom.

Selection of rockfall mitigation was done in such a way that the small or medium size detached loose boulders are guided through the drapery/netting system and it shall be reach at toe of slope. And that boulder, debris shall be remove periodically as part of maintenance to accommodate further disintegrated rocks.

The height of cutting to be protected was 6m to 15m. The slope angle of cut section is varying from 55° to 70°. The rockfall protection system will prevent the fall of any rock pieces directly on road and it will guide the boulder to fall at toe of the hill slope and hold the disintegrated rocks, where the bottom anchors are placed.

The special 5.5 twisted wire mesh is made of Heavily Galvanized steel wires with PVC coating. The twisting is done mechanically and is non-raveling in nature.

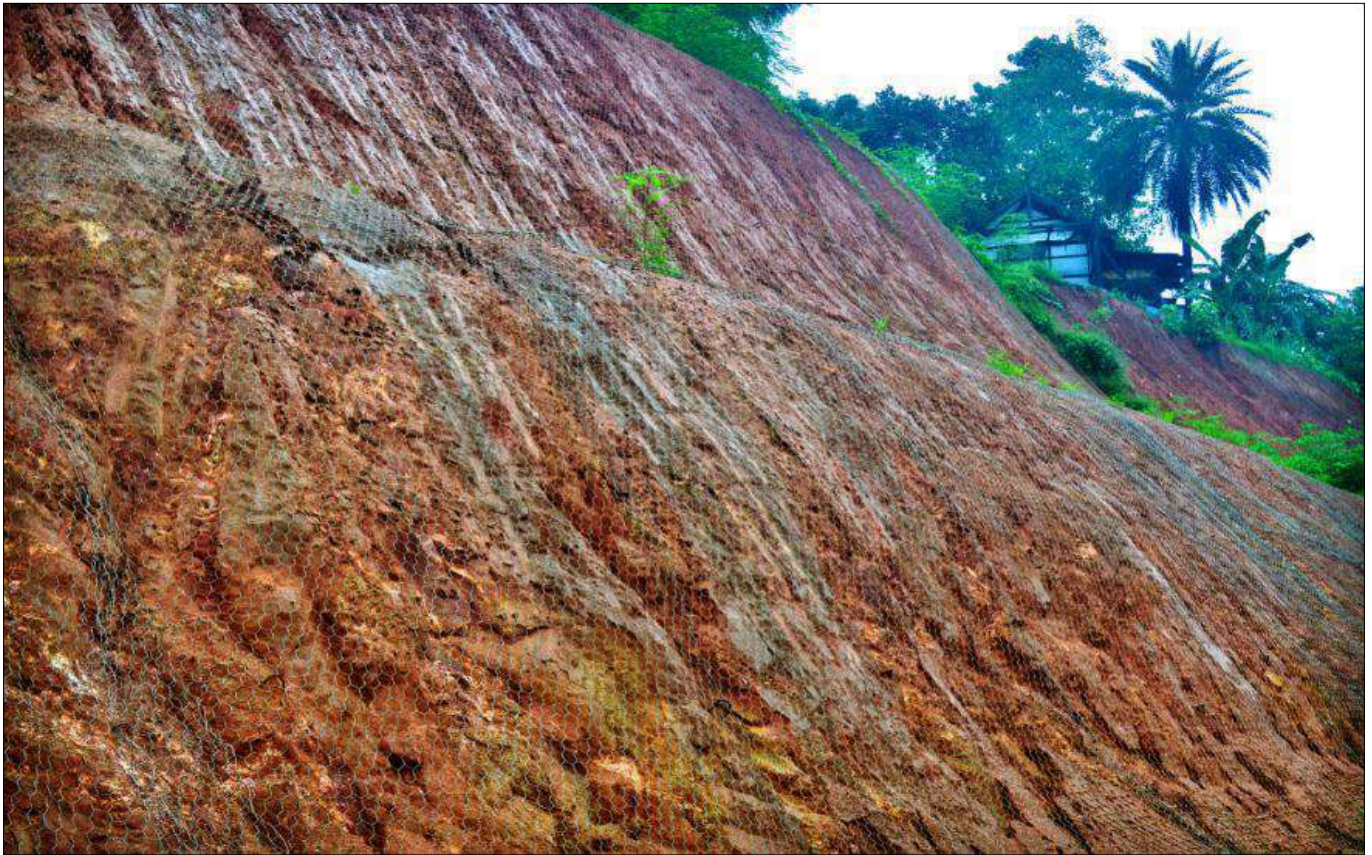

Slope after installation of Rockfall Netting

Advantages of using TechFab Rockfall Netting :

- High loading capacity.
- High flexibility.
- Uniform distribution of the tension.
- Excellent buffering performance.
- Corrosion and rust resistance.
- Durable and long service life.

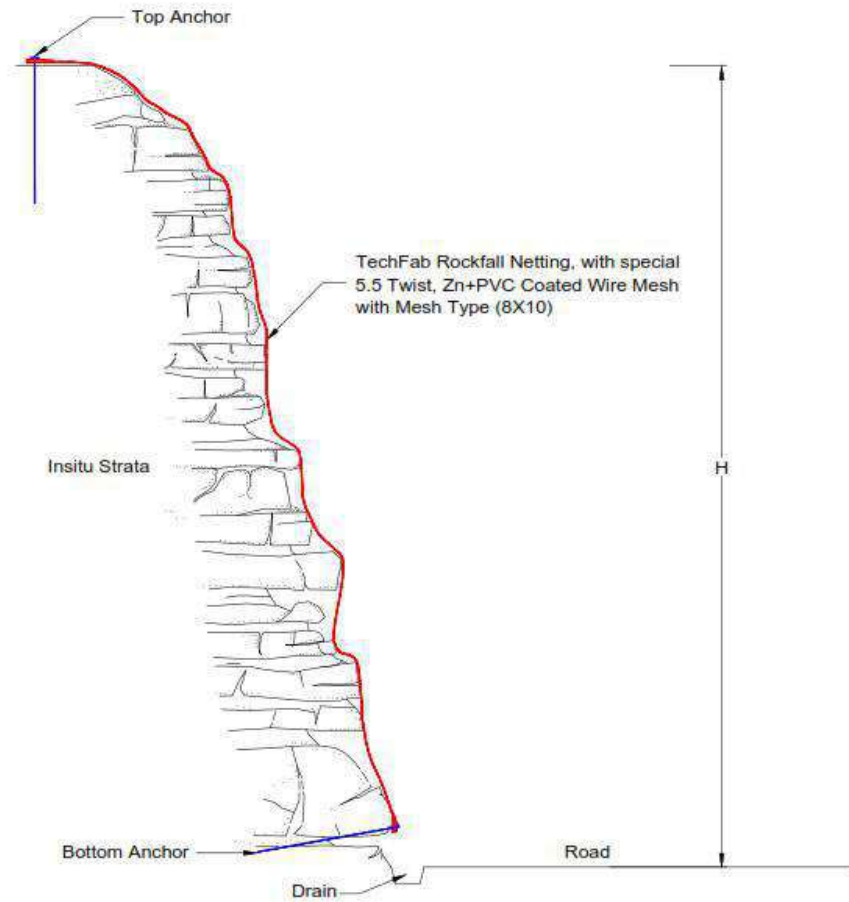

Typical Cross Section drawing



Top of Slope after Vegetation has grown

Execution at Site :

- Before a drapery system was installed, the slope was thoroughly scaled and the anchors were installed.
- Unless the drapes were rolled out from the top of the slope, a staging area at the slope base was required to prepare the drapes for installation.

Equipment used for installing a drapery system includes the following:

- Drill for installation of mesh anchors. A hand-held drill with a man lift or a track drill was typically used for the anchor installation.
- Crane was used for placing the wire mesh.

The majority of maintenance on a drapery system consists of removing trapped material in order to prevent over-loading of the wire mesh. Limited vegetation growth within the mesh area did not reduce the effectiveness of the mesh, but large shrubs or trees may cause problems and be removed. The toppling of trees may cause both global and localized failure.

- All items were checked at the time of delivery. Items were moved to the site using cranes.
- Before the installation of any materials, the crest area and slope face were prepared.
- The crest was cleared of all significant or dense vegetation (see right) to promote easy and safe access and to enable simple manipulation and placement of mesh etc.
- Following the crest clearing the slope face was cleared by the process of “de-scaling”. This typically included removal of loose rocks, soil, and excessive vegetation growth from the slope face This work was overseen by



Top of Slope after Vegetation has grown



Top of Slope after Vegetation has grown



Slope after installation of Rockfall Netting



Structure after 7 years

Conclusion:

For this project, special five and half twisted metal wire mesh netting was produced. Client was happy with quality of material supplied and prompt support from our team. Project was completed within given timeline.

It has been 7 years since project is completed. Rock fall protection system faced many worst monsoons still and the system is working as per the project requirement and desired by the client.

For further details kindly contact :

TechFab India Industries Ltd.

711/712, Embassy Centre, Nariman Point, Mumbai – 400021

Tel: + 91– 22 - 2287 6224 / 6225 Fax: + 91– 22 - 2287 6218

E: info@techfabindia.com

W: www.techfabindia.com

CASE HISTORY

Rev:00, Date : 21.02.2023

FLOOD MITIGATION & RIVER BANK PROTECTION USING TECH GEOMATTRESS ALONG BRAHMAPUTRA RIVER BANK, NORTH LAKHIMPUR, ASSAM NORTH LAKHIMPUR, ASSAM, INDIA



River Bank Protection

Client:	Products used:
WATER RESOURCE DEPARTMENT, ASSAM	• TECH GEOMATTRESS - 9400 SQM.
Main contractor:	
M/S. STAR CONSTRUCTION	
Manufacturer & Supplier:	Year of Construction:
TECHFAB (INDIA) INDUSTRIES LTD.	2022

Project Brief & Problem Description:

Floods are one of the most frequent natural calamities in India. India witnessed several riverine floods historically that affected millions of people, caused loss of lives, and damaged infrastructure and agriculture. An increasing number of flood cases in recent times has increased the importance of flood protection works and the raising of embankments in urban and rural plains. The high shear force of flowing water and migration of soil particles leads to the progressive erosion of river banks. The damage to the natural banks reduces the bund height and may let the flood water spill out of its banks which causes floods.

The river Brahmaputra has been the lifeline of northeastern Indian states for ages. This mighty river runs for 2880 km through China, India, and Bangladesh. Every year the Northeastern state of Assam experiences huge losses due to devastating floods caused by the river Brahmaputra. Some northern plains of Assam like Dhemaji, North Lakhimpur, Dhakuakhana and a few places of Barak Valley experience significant damage due to floods in the Brahmaputra Basin very frequently. The high intensity of floods in the Brahmaputra River and the steep topography of the region makes the problem more complex and severe.

To provide a safeguard against the frequent floods in the region, the banks of the river Brahmaputra near Lakhimpur were required to be protected at a few stretches while providing sustainable anti-erosion measures.

Solution:

We, at TechFab India, suggested using Tech GeoMattress (A Uniform Tubular Green Mattress) filled with sand (100mm post filling) on the river bank side slope. The work was carried out on the left bank of the Brahmaputra River for a total length of 700m (Approx.) where the river bank was dressed to a slope inclination of 2H:1V for the maximum protected bank height of 12.0m.



TECH GEOMATTRESS :

TECH GEOMATTRESS is a double layered three-dimensional tubular green mattress which is used to form a protection system on the bed and side slopes of a water channel. Tech GeoMattress is a well-established eco-friendly flexible solution which can cater for the needs of various flood control applications. It is fabricated from two layers of geotextile; the upper layer is a green coloured composite fabric having green cut fiber on the top for UV and abrasion protection and the bottom layer is made up of high strength woven fabric which provides a base and adequate filter properties to the mattress system.

Photo 1 : Installation of Tech GeoMattress

The attractive green fabric on the top blends with the surroundings and helps in developing vegetation growth by entrapping the sediments within the grooves of the sausages. The tubular shape of the mattress helps in dissipating the energy of the longitudinal currents and wave action of the streams which in turn controls the erosion and development of scour holes.

Tech GeoMattress was anchored on the top by providing an anchor trench at the top. A toe trench was provided at the low water level of the embankment slope by bending the mat into the trench of size 1.0 m x 0.75 m and filled with locally available earthen materials.

The infill soil should be preferably coarse sand and free from organic material. The materials available in the northern plains of the Brahmaputra River are sandy & silty soil, which often do not possess adequate cohesion and internal stability. However, these materials provide excellent filler properties to be used in Tech GeoMattress. Therefore, locally available soil was used as infill material.



Photo 2 : Laying of Tech GeoMattress on Dressed Slope

ADVANTAGES OF USING TECH GEOMATTRESS :

- Tech GeoMattress is delivered in rolls which can be easily transported to the site.
- Tech GeoMattress systems utilize locally available sand for the construction of bank protection system. Therefore, It is economical and environment friendly as compared to conventional solutions.
- Installation is quick and uses simple equipment. They can be rapidly mobilized for emergency work at site.
- Tech GeoMattress system is economical and easy to install without the requirement of skilled labours. They are ideal solutions for areas with poor accessibility and handling of precast concrete units and rip-rap.
- Tech GeoMattress is a flexible system. Hence it usually attains the shape of the surface irregularities which Makes it easier to install at the site.
- These fabrics can be engineered to suit most site conditions in terms of mechanical strength. Its less Apparent Opening size helps to retain the finer soil particles and its high permeability ensures quick dissipation of pore water pressure.
- It is an effective erosion protection solution for the long run with high robustness and durability of the composite geotextile fabric with excellent abrasion and UV resistance properties.

INSTALLATION OF TECH GEOMATTRESS :

The following sequence were adopted for the laying of Tech GeoMattress:

- Tech GeoMattress is easy to install at site and uses simple equipment without the requirement for skilled labour, installation can be done hydraulically, mechanically or pneumatically.
- At first, prepare slope surface as per approved drawings and project requirements. Remove debris, rocks, unacceptable soil from area where Tech GeoMattress is to be laid.
- Replace removed soil with acceptable soil and compact earthwork.
- Excavate top and bottom trench according to drawings provided.
- Tech GeoMattress should be laid along the profile of the slope from top to bottom. It enables easy filling of the mattress on site.
- In this direction, the seams between the tubes are under tension while filling which helps to achieve the desired thickness of the mattress after filling.
- Adjacent rolls of sand-filled mattresses are joined by seaming on site.
- Sand-filled mattress is anchored in the trenches at the top and bottom of the slope.
- The recommended size of the anchor trench should be 1.00 m x 0.75 m.
- The mat should be placed by bending it into the trench. The trench can be filled with earth fill, boulders or Geobags.
- When the Tech GeoMattress has been laid in place properly, it should be filled with sand in slurry form, which reduces its permeability significantly.

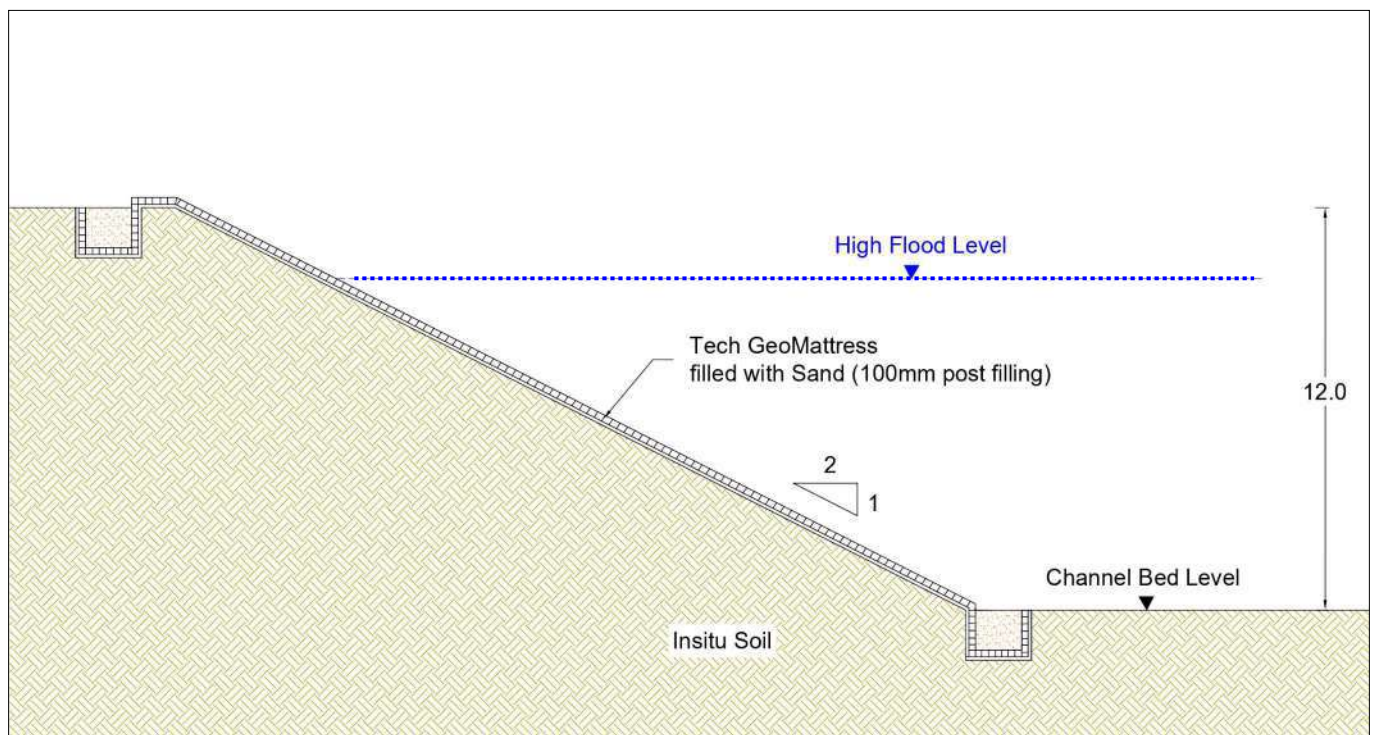

Typical Cross Section of Proposed Solution



Photo 3 : After Completion Photograph

Conclusion:

The project was completed successfully and performing to the intended purpose, to the satisfaction of the client and contractor.

For further details kindly contact :

TechFab India Industries Ltd.

712, Embassy Centre, Nariman Point, Mumbai – 400021

Tel: + 91- 22 - 2287 6224 / 6225 Fax: + 91- 22 - 2287 6218

E: info@techfabindia.com

W: www.techfabindia.com

CASE HISTORY

Rev:01, Date : 16.06.2020

SLOPE PROTECTION OF SWAN RIVER IN THE STATE OF HIMACHAL PRADESH USING TECHGEO PN 30 AS GEOTEXTILE FILTER CLOTH HIMACHAL PRADESH, INDIA



Flood Protection Works

Client:	Products used:
	PP NON WOVEN GEOTEXTILE TECHGEO PN 30
Main contractor:	Quantity Supplied:
Manufacturer & Supplier:	Year of construction:
TECHFAB (INDIA) INDUSTRIES LTD.	2014

Project Description:

The river Swan originates from Joh-Marwari village near Daulatpur Chowk in Amb tehsil in district Una, Himachal Pradesh. The river then flows through district Una and after traversing a distance of 85 km, the river Swan confluences with river Satluj at Anandpur Sahib in Punjab. The Swan River traverses a total distance of 65 km in Himachal Pradesh. The river Swan has a total catchment of 140,000 ha out of which 120,000 (85.7%) ha lies in the Himachal Pradesh. The river is fed by about 73 tributaries during its traverse in Himachal Pradesh.

In district Una, river Swan flows through inter-mountainous valley. The Catchment of river Swan is largely degraded due to significant human interferences. The forests have been cleared to meet the fuelwood, fodder and timber requirements, or for commissioning of various infrastructure projects. This has led to serious drainage problems. As a result, the entire precipitation results in rapid flow into the tributaries which ultimately reach Swan river. It results in flash floods leading to heavy floods causing large scale erosion of land, damage to property and crops, disruption of communication, loss of human lives and livestock, etc. Pebbles, gravel, soil, etc. are deposited in the early reaches of the tributaries and fine sediments consisting of sand, etc. flow with the run off and ultimately get deposited on agriculture fields causing heavy damage to land and property.

The task of flood management of Swan River is therefore of utmost importance. The total cost of the rehabilitation is 160 crores to be funded by Japanese Bank and Govt. of Himachal Pradesh and to be completed within a period of 8 years. The banks are required to be restored & completed by Financial Year 2014. But the authorities are hopeful to get the project completed by Start of Year 2012.

Project Details:

The methodology of River Bank Protection was proposed by M/s WAPCOS using Crated Apron, Geotextile and Stone Pitching on the Embankment. The crated aprons at the toe are so provided Swan River experience flash floods every season.

The project comprises of the following main components:-

- Embankment
- Stone spur
- Sluice gate

Embankments & Spurs

The core of the embankment shall be of clayey soil and spur will be in stones duly filled in wire crates. The top width of embankment is 6m with side slope of 2:1. Free board of 1m is kept and seepage protection is through clay core. The details of various protection measures are given in Table below.

Items	Embankments	Spurs
Stone pitching	30 cm thick with stones in 1.5 m x 1.5 m x 0.3 m size of wire crates	Stone core made up of crates of size 1.5m x 1.5m x 0.3m. Well anchored/ connected to the embankment.
Aprons	Aprons of width 6 m to 10 m of thickness 0.6 m in crates of size 1.5 m x 1.5m x 0.3 m in 2 layers (Average width 6.0 to 7.0 m)	Aprons of width 15 m made up of stones in crates of 1.5m x 1.5m x 0.3 m in single layer.
Filter bed	Conventional Filter Bed shall be replaced by using PP, Non-Woven Needle Punched Geo provided under launch apron and pitching.	Geo-fabric filter under spur and its apron.

Techgeo PN 30 as Geotextile Filter

The proposed Filter Cloth was seen as a replacement of conventional filter media comprising of graded aggregates hence was replaced with more effective PP Non Woven Geotextile of 300 GSM to control the properties as per the requirement of design by M/s WAPCOS.

Separation

TechGeo acts to separate two layers of soil that have different particle size distributions. This prevents base materials from penetrating into underlying soft subgrade soils, thus maintaining design thickness and integrity of the layer.

Filtration

This allows water to move through the soil while retaining all upstream soil particles. It is used to prevent soils from migrating into drainage aggregate or pipes while maintaining flow through the system.

Drainage

TechGeo acts as a drain to carry fluid flow through less permeable soils. It dissipates pore water pressures at the base of embankments.

Property	Test Method	Value
Physical		
Mass per unit area	ASTM D 5261	300g/m ²
Thickness	ASTM D 5199	2.8 mm
Mechanical		
Grab Tensile Strength	ASTM D 4632	1150N
Grab Elongation	ASTM D 4632	50%
Wide Width Tensile Strength	ASTM D 4595	19.00 KN
CBR Puncture	ASTM D 6241	3900 N
Trapezoidal Tear	ASTM D 4533	475 N
Hydraulic		
Apparent Opening Size(dry)	ASTM D4751	150µm
Permeability	ASTM D4491	160 lts/sqm/sec
Endurance		
Ultraviolet resistance @ 500 hours	ASTM D 4355	70%

Specification of Techgeo PN 30

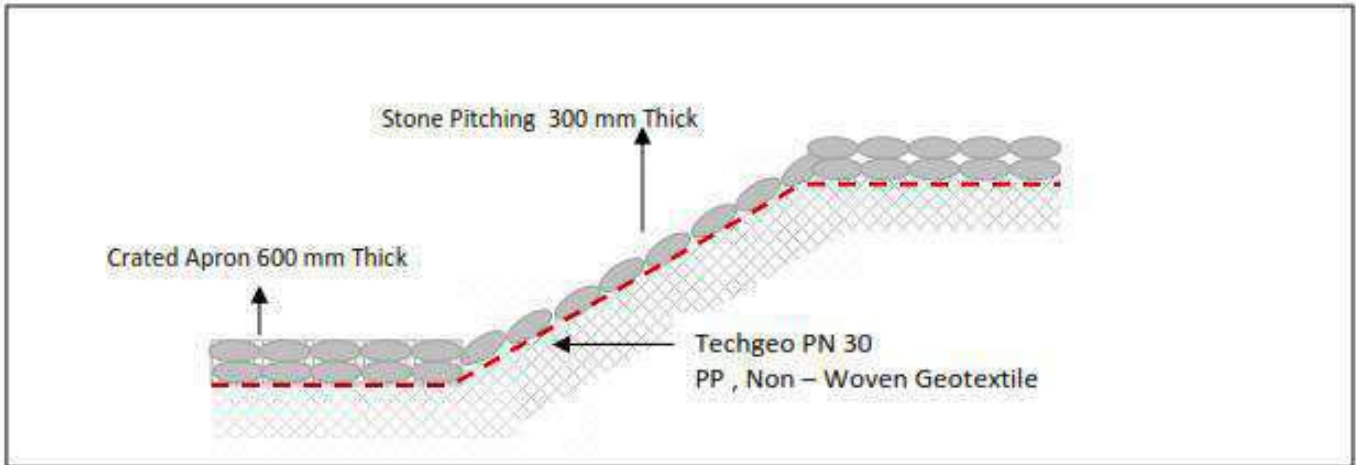

Typical Drawing



APRONS

Aprons of width 6 m to 10 m of thickness 0.6 m in crates of size 1.5 m x 1.5m x 0.3 m in 02 layers (Average width 6.0 to 7.0 m)

STONE PITCHING

300 mm thick with stones in 1.5 m x 1.5 m x 0.3 m size of wire crates

TECHGEO PN 30

PP, Non - Woven Geotextile used as Filter beneath Apron/Stone Pitching



For further details kindly contact :

TechFab India Industries Ltd.

711/712, Embassy Centre, Nariman Point, Mumbai – 400021

Tel: + 91- 22 - 2287 6224 / 6225 Fax: + 91- 22 - 2287 6218

E: info@techfabindia.com

W: www.techfabindia.com

CASE HISTORY

Rev:01, Date : 16.06.2020

PROTECTION WORKS TO ERODING LEFT BANK OF RIVER CHURNI AT RABON- BORE, RANAGHAT, NADIA, WEST BENGAL NADIA, WEST BENGAL, INDIA



River Bank Protection

Client:	Products used & Quantity Supplied:
GOVERNMENT OF WEST BENGAL, NADIA IRRIGATION DIVISION, I & W DIRECTORATE, NADIA	TECHGEO NON WOVEN GEOTEXTILE PN 25 TECHGEO NON WOVEN GEOTEXTILE BAGS 420GSM
Main contractor:	Consultant:
TULIP CONSTRUCTION & SUDIP ROYCHOUDHURY	
Manufacturer & Supplier:	Year of construction:
TECHFAB (INDIA) INDUSTRIES LTD.	

Project brief & Challenges:

Churni was actually an artificial canal built by the Maharaja Krishna Chandra, King of Nadia, in order to protect the region from the enemies. However, due to the tragic flood over the years, the artificial canal built turned into river, caused erosion at the bank of the river. Effect of erosion was so serious that it caused serious losses in the form of loss of agricultural land, home, property, loss of lives, economic loss are a few to name. Embankment bank protection with conventional methods such as rip-rap had proved to be costly and unyielding over a longer period of time. As clear from the photographs above, the existing embankment slope was severely eroded due to the flood in the river.

Thereby in order to mitigate the erosion, TechFab (India) Industries Ltd suggested the TechGeo Nonwoven Geotextile and TechGeo Nonwoven Geotextile Engineered Fabric Bags with high abrasion resistance. Government of West Bengal, Nadia Irrigation Division, I & W Directorate, Krishnagar, Nadia awarded the protection works to eroding left bank of river Churni at Rabonbore for a length of 650m in Block – Ranaghat – I, P.S – Ranaghat, Dist. – Nadia, West Bengal to M/s TULIP Construction & M/s SUDIP ROYCHOUDHURY.



Before Rehabilitation – Churni River Bank



Before Rehabilitation – Churni River Bank

Solution:

TechFab (India) Industries Ltd suggested the use of TechGeo Nonwoven Geotextile PN25 over the Embankment slope surface, to act as a filter fabric for prevention of soil erosion. Also TechGeo Nonwoven Geotextile Engineered Fabric Bags with high abrasion resistance of 420 Gsm was suggested to be placed at the bank of the river, to reduce the impact of waves over the embankment slope surface.

Execution

To protect the embankment against further erosion, the following step by step procedure was adopted:

1. The existing embankment slope of approximately 25m length was dressed properly to attain a working surface by smoothening out the top soil.
2. A trench of 2' deep x 4' wide was made at the top and bottom end of the embankment slope.



Dressing of the Embankment Slope



Excavation of Trench at the End

3. A layer of TechGeo Needle Punched Nonwoven Geotextile PN25 was laid as Filter Fabric, over the prepared slope surface.

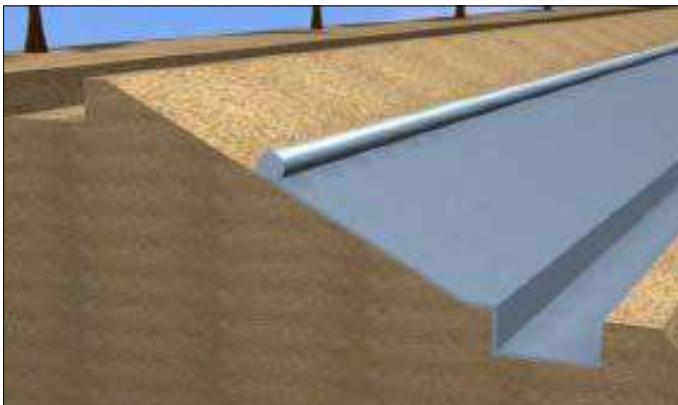

Unrolling of TechGeo Nonwoven Geotextile



Unrolling of TechGeo Nonwoven Geotextile

4. In order for the TechGeo Nonwoven Geotextile to function properly it should be laid taut over the surface. Therefore, a metal gabion filled with boulders was placed in the top and bottom trench, to secure the TechGeo Nonwoven Geotextile in place.

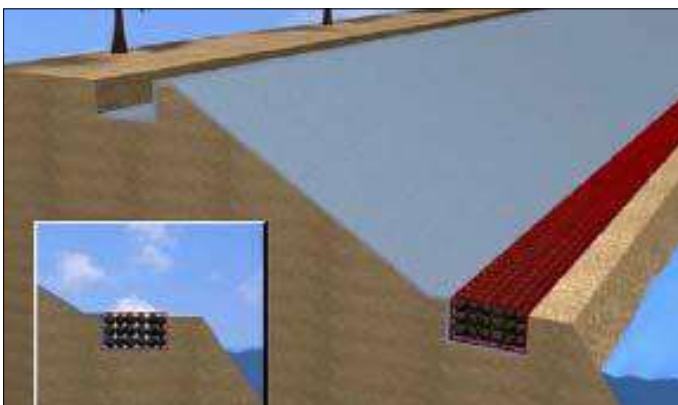

Metal Gabion Placed at Bottom Trench



Metal Gabion Placed at Bottom Trench

5. The embankment slope covered with TechGeo Nonwoven Geotextile was further protected with two layers of bricks that were readily available.

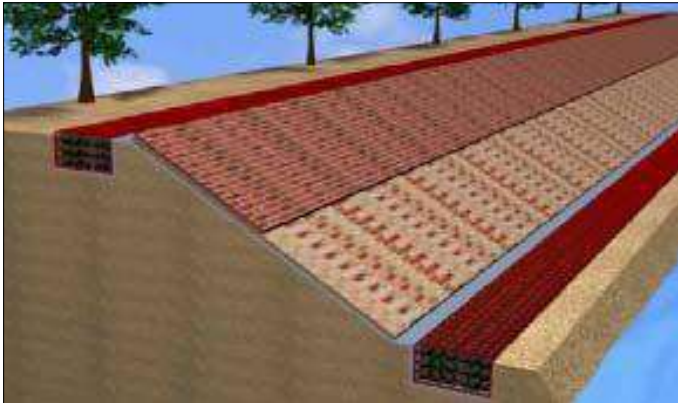

Two Layers of Brick Placed Along the Slope



Two Layers of Brick Placed Along the Slope

6. Further, 6500 nos. of TechGeo Nonwoven Geotextile Bags filled with locally available fine sand, were laid in two layers at the edge of the river bed to take care of the soil erosion. The size of each TechGeo Nonwoven Geotextile Bag was 1m x 1.5m with the weight of the each filled bag of approximately 80 to 90 kg. These bags are engineered fabric bags with high abrasion resistance of "Pillow Type" duly "Chain Stitched" in 3 lines at TechFab (India) Industries Ltd's manufacturing facility.

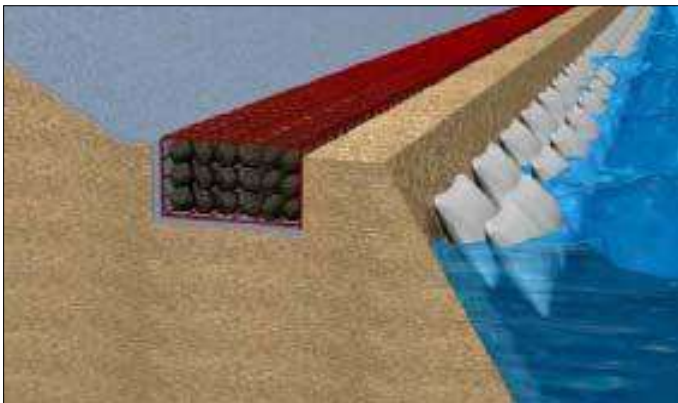

TechGeo Nonwoven Geotextile Bags in Two Layers at the Edge of the River Bed



TechGeo Nonwoven Geotextile Bag Being Filled with Local



After Rehabilitation – Churni River Bank

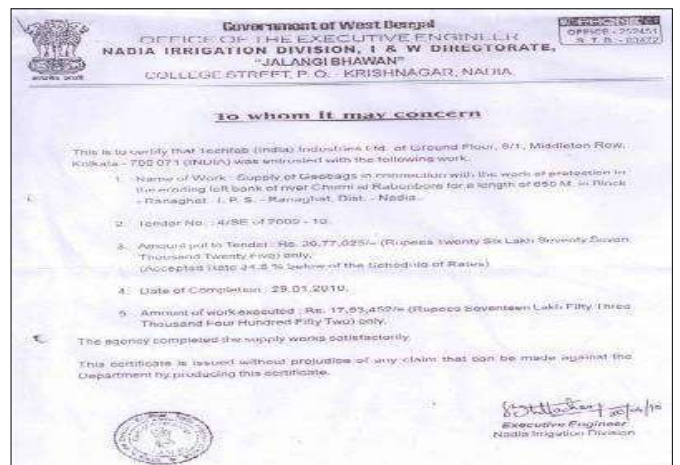

Completion Certificate Supply of TechGeo Nonwoven Geotextile Bags

Benefits of TechGeo Needle Punched Nonwoven Geotextile:

1. Geotextile functions as a filter.
2. Geotextile prevents soil from embankment from being washed away.

Benefits of TechGeo Nonwoven Geotextile Bags:

1. TechGeo Nonwoven Geotextile Engineered Fabric Bags with high abrasion resistance provide reinforcement to the edge of the embankment.
2. Reduces the damage to the base embankment considerably.
3. Life of embankment extends exponentially.

Advantages of Geosynthetic Solution v/s Conventional Riprap:

1. Reduction in Granular layers.
2. Considerable saving of construction time.
3. Longer life of the embankment even after repeated floods.

For further details kindly contact :

TechFab India Industries Ltd.

711/712, Embassy Centre, Nariman Point, Mumbai – 400021
Tel: + 91- 22 - 2287 6224 / 6225 Fax: + 91- 22 - 2287 6218
E: info@techfabindia.com
W: www.techfabindia.com

CASE HISTORY

Rev:00, Date : 29.06.2020

ANTI EROSION MEASURES FOR BANK PROTECTION ALONG THE RIGHT BANK AT BOGDEBRI AND LEFT BANK AT NISHIGANJ OF RIVER MANSAI AT COOCHBEHAR DISTRICT IN WEST BENGAL

COOCHBEHAR, WEST BENGAL, INDIA



Flood Protection Works

Client:	Products used & Quantity Supplied:
BRAHMAPUTRA BOARD - JALPAIGURI DIVISION	TECHFAB GEOTEXTILE BAGS, SIZE 1.2 X 1.0m - 87520 NOS.
Main contractor:	TECHFAB GEOTEXTILE BAGS, SIZE 2.0 X 1.5m - 39876 NOS.
Manufacturer & Supplier:	Year of construction:
TECHFAB (INDIA) INDUSTRIES LTD.	2020

Project description and Challenges :

Coochbehar is a District under the Jalpaiguri Division of the state of West Bengal, is located just at the foot of the mountain. The rivers arrive here at the plain terrain immediately after coming down of the mountain, so the velocity and energy level of the rivers get dissipated here and results deposition of huge river bed materials on the river bed. It is the common phenomenon of the north Bengal Rivers particularly, of this District Rivers, the beds of the rivers are getting raised due to deposition, it also results meandering of river courses. The rivers change their courses irregularly resulting loss of land and properties.

The River Mansai originates from the Bedang Lake in Sikkim. After flowing through Sikkim, Bhutan, Darjeeling and Jalpaiguri districts it enters into Coochbehar district. There are often flush Flood on this river due to heavy rainfall and the bed level of river is gradually rising due to heavy siltation resulting which reducing the water carrying capacity of the river and threatened the adjacent area in respect of Flood and Erosion for the last few years.

To mitigate this problem, The Brahmaputra Board, Jalpaiguri division had proposed bank protection works. The anti-erosion works were implemented along right bank at Bhogdebri and along left bank at Bhajaner cherra, Nishiganj of Mansai River, that has been identified as highly affected zone.

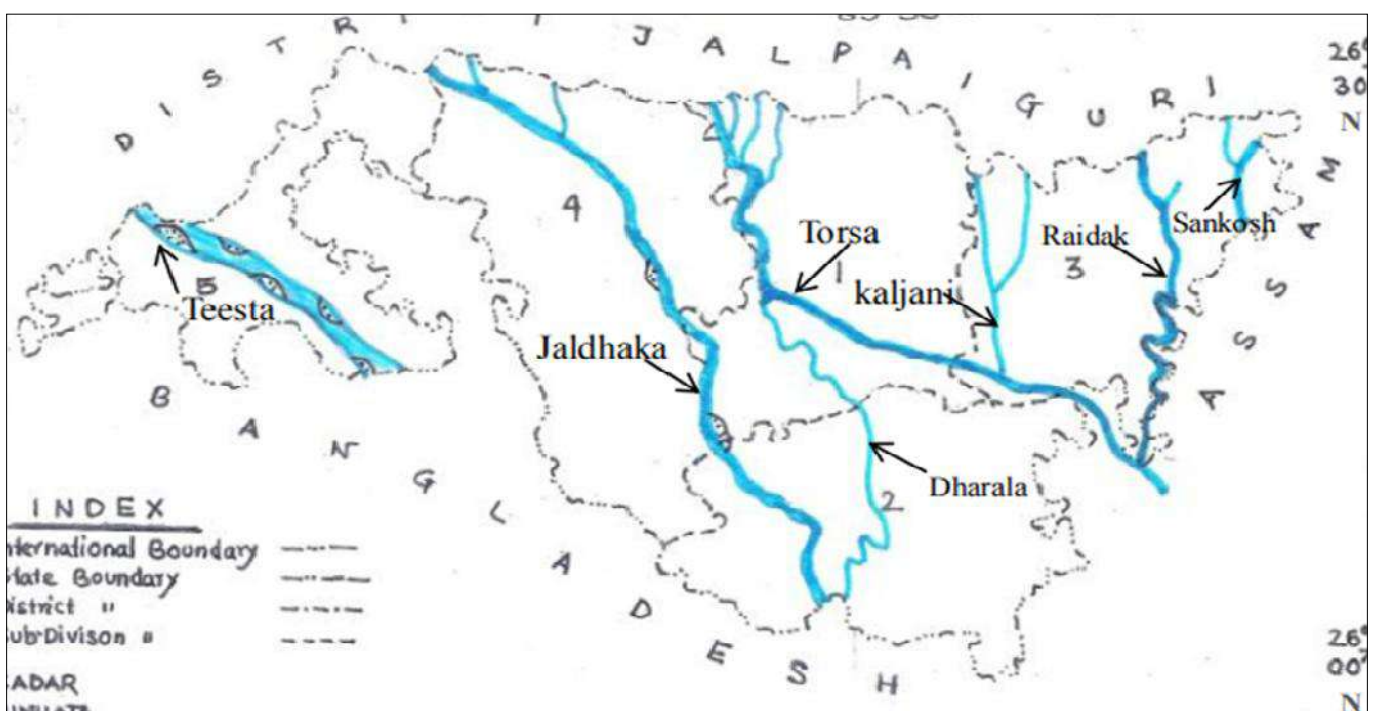

Map showing the Rivers in Coochbehar

Solution :

The Brahmaputra Board has suggested the use of TechFab geotextile bags for the bank protection, which is one of the most practical and viable solutions. The Geotextile bags filled with locally available sand commonly adopted for hydraulic protection works. These geotextile bags are produced from either woven or non-woven polypropylene geotextile or non-woven polyester geotextile. It is cost effective solution largely used in flood protection measures .

The solution was finalized using Geotextile bags for construction of Longitudinal structures which will be permeable, economical and effective in terms of control sedimentation. The main purpose of this structure is to prevent flooding of the adjoining villages and to slow down or stop the shifting of natural water way.



Photo 1 & 2 - Filling & Placement of TechFab Geotextile bags

Execution on site:

- Setting out the area
- Mobilisation of Geotextile bags and soil to the project site.
- The excavated soil was disposed of by tippers to a suitable distance from bank side to reduce overburden of bank.
- The slope formation was done with necessary ramming to remove any undulations and corrected to the desired slope
- The bags were filled with locally available River Sand; the sand used as filling was as per technical specification of the project.
- After sand filling was completed, the geotextile bag was weighed to confirm the desired weight as per technical requirement.
- After confirmation of weight, bag was stitched by special hand held stitching machine.
- For the convenience bags were stored in batches or any suitable multiples as per available space at site.
- The dumping/laying of geotextile bags for launching apron was carried out when river was dry or with the help of small boats to complete the activity on time.
- Laying of bags was done under supervision of the site in charge. Laying work was inspected time to time by authority.



Photo 3 - Placement of Techfab Geotextile bags



Photo 4 - Placement of Techfab Geotextile bags

Conclusion:

The project is completed successfully. The client was very happy and satisfied with product quality of TechFab India industries Ltd.

For further details kindly contact :

TechFab India Industries Ltd.

711/712, Embassy Centre, Nariman Point, Mumbai – 400021
Tel: + 91- 22 - 2287 6224 / 6225 Fax: + 91- 22 - 2287 6218
E: info@techfabindia.com
W: www.techfabindia.com

CASE HISTORY

Rev:01, Date : 11.04.2020

FLOOD PROTECTION WORKS ON THE DOWNSTREAM OF RIVER SHARDA / GHAGHARA AT LAKHIMPUR, UTTAR PRADESH

LAKHIMPUR, UTTAR PRADESH, INDIA



Flood Protection Works

Client:	Products used & Quantity supplied:
	TECHFAB GEOTEXTILE BAGS, SIZE 1.09X0.69m
Main contractor:	(TFI 1200 - MADE FROM 100% PPMF GEOTEXTILE - 197000 NOS.
Manufacturer & Supplier:	Year of construction:
TECHFAB (INDIA) INDUSTRIES LTD.	

Problem:

The Lakhimpur - Khiri has witnessed several floods in the past due to heavy rainfall, it was observed by the locals that this flood or rise of water level in Sharda River is due to heavy rainfall in this region and the addition of new water in the river from upstream side from Nepal generally in the month between June to September every year. The lives of the people get affected due to flood every monsoon due to proximity of the people residing on the banks or fall under flood influence area of the River Sharda & Ghaghara. Both these rivers have recorded high velocity and frequently changing their course in the past.

The location is Lakhimpur - Khiri @ 137 km from Lucknow. Every year during monsoon, the difficulties were faced by the local habitants to the large extent by loss / damage to the property, loss of agriculture /farm land, loss of Cattle etc.



Photo 1: View of Flood



Photo 2: Aerial view of Ghagra river at Lakhimpur - Kheri Area

Project Challenges:

Most of the rivers in this region originate from the high mountains, where they have steep gradients giving the flow a massive erosive power. Moreover, intense rainfall and breakout events can accelerate the river flow to such an extent that the water has a significant impact on the watercourses and surrounding areas.

The construction challenge was to meet the construction schedule before monsoon and the mobilization of soil for construction of Dyke. The earthen dyke is subjected to either loss of fines or breach of partially constructed bund due to wetting and drying everyday.

Solution:

Generally as conventional approach, big boulders are used for river training work. However, mobilizing such huge quantity of stones in short span of contract period is difficult and moreover it is very expensive. Further extraction of stones in huge quantity would affect the environment balance. Transporting and handling the material to work site is another issue and needs involvement of machinery to handle it.

Geotextile bags filled with locally available soils is the effective alternative against all other options; It is cost effective solution largely used in flood protection measures. The design was finalized using Geotextile bag for construction of Longitudinal and Transversal protection structures which will be permeable, economical and effective in terms of control sedimentation .

The Flood protection work / dikes using Geotextile bags (longitudinal protection structure) and construction of porcupine spur (Transversal Protection Structure).

The main purpose of both structures is to prevent flooding of the adjoining villages and to slow down or stop the shifting of natural water way.

Groynes / spurs are constructed transverse to the river flow extending from the bank into the river. This form of river training works perform one or more functions such as training the river along the desired course to reduce the concentration of flow at the point of attack, creating a slack flow for silting up the area in the vicinity and protecting the bank by keeping the flow away from it.



Photo 3: Porcupine concrete spurs

Execution on site:

- Setting out the area as per drawing
- Mobilisation of Geotextile bags and soil to the project site.
- The excavated soil was disposed of by tippers to a suitable distance from bank side to reduce overburden of bank.
- The slope formation was done with necessary ramming to remove any undulations and corrected to the desired slope before laying nonwoven geotextile.
- The geotextile was laid across the dressed slope over which sand filled geotextile bags were placed.
- The bags were filled with locally available River Sand; the sand used as filling was as per technical specification of the project.
- After sand filling was completed, the geotextile bag was weighed to confirm the desired weight as per technical requirement.
- After confirmation of weight, bag was stitched by special hand held stitching machine.
- For the convenience bags were stored in batches or any suitable multiples as per available space at site.
- The dumping/laying of geotextile bags for launching apron was carried out when river was dry or with the help of small boats to complete the activity on time.
- Laying of bags was done under supervision of the site in charge. Laying work was inspected time to time by authority.
- Laying of porcupine concrete element was carried out as per drawings and installation guidelines for spur construction.



Photo 4: The Flood protection work / dikes using geotextile bags

Conclusion:

It is observed that Completed Geotextile bags structure withstood recent flood of 2019 without any major damage of the properties, loss of land and without loss of any cattle or people. The protection is serving as desired by the authority. It is also observed that the river has changed its course @ 9 -10m from its existing flow profile and deposition of the sand at multiple locations.

For further details kindly contact :

TechFab India Industries Ltd.

711/712, Embassy Centre, Nariman Point, Mumbai – 400021

Tel: + 91– 22 - 2287 6224 / 6225 Fax: + 91– 22 - 2287 6218

E: info@techfabindia.com

W: www.techfabindia.com

CASE HISTORY

Rev:00, Date : 27.12.2022



TECHTUBE GEOTEXTILE TUBES FOR PROTECTION OF EXISTING GEOTEXTILE TUBE PROTECTED ISLAND AT CHERUVATHUR FISHERY HARBOUR, KASARAGOD, KERALA KASARAGOD, KERALA, INDIA

Coastal Protection

Client:	Products used:
HARBOUR ENGINEERING DEPARTMENT, KERALA	TECHTUBE GEOTEXTILE TUBES
Main contractor:	Quantity supplied:
K J ROBERT	
Manufacturer & Supplier:	Year of construction:
TECHFAB (INDIA) INDUSTRIES LTD.	2022

Problem:

Cheruvathur fishing harbour also known as Madakkara fishing harbour located around 4km from Cheruvathur town in Kasaragod district, Kerala.

During the year 2018 - 2019, the Harbour Engineering Department constructed the 15 acre artificial island (400m long and 150m wide) in the river near Madakkara fishing harbour. This artificial island was built using sand dredged from the river to create a boat channel for the smooth passage of fishing boats and canoes to and from the Madakkara harbour. This was protected by geotextile tubes.

Due to the illegal mining of sand along the north west portion near to the sea of this island, the shoreline had been exposed to severe erosion, caused sinking of existing geotextile tubes. Now some area of this island is utilized for Miyawaki (Akira Miyawaki) jungle works and this island is a protection to the landed craft on the basin against the sea waves. So it was necessary to protect the coastline by placing a new layer of Geotextile Tubes of length about 340m near the existing Geotextile tubes on the shore side.



View of Artificial Island near Madakkara fishing harbour



Damaged existing Geotextile Tubes

Solution:

TechTube Geotextile Tubes made of engineered high strength woven fabric filled with dredged material, have been used to protect the existing Geotextile Tubes and to prevent erosion of the beach. Geotextile tube technology has changed from being an alternative construction technique and, in fact, has advanced to become the most effective solution of choice to protect the shorelines.

The Geotextile tubes are sustainable since being manufactured from high-quality Virgin Polypropylene material can offer the function of containment, filter, and reinforce soil. The permeability of the soil fill and geotextile has a significant influence on the tube structure. The geotextile for tube manufacturing has been selected based on the performance requirement parameters like strength; filter (AoS); type of infill soil material; seam strength & durability parameters, etc.

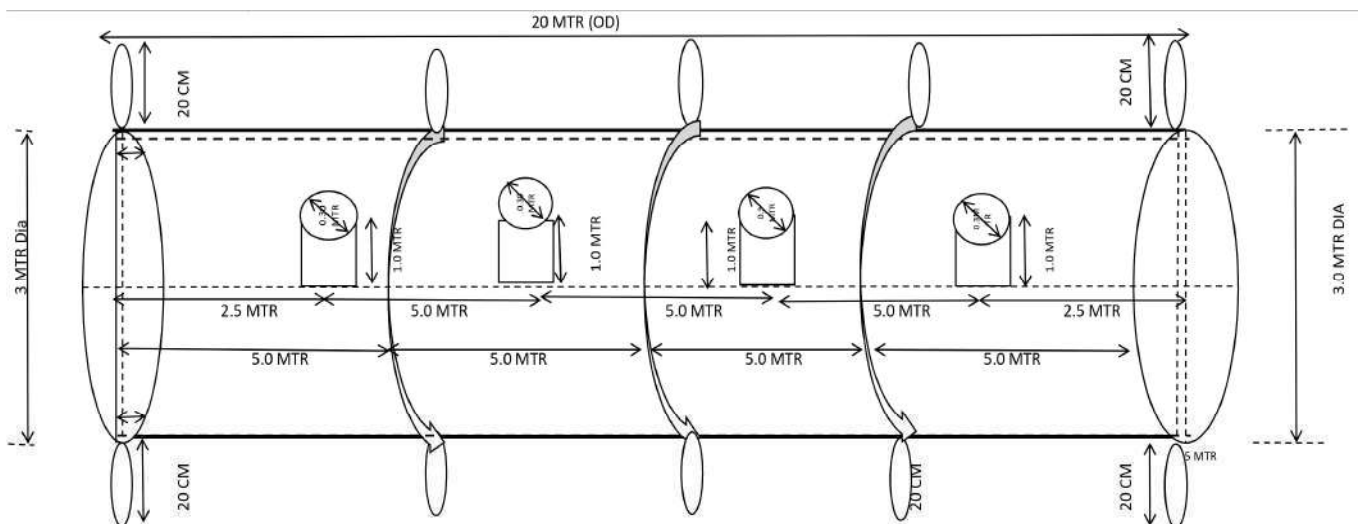

Typical Cross section drawing

Advantages of using Geotextile Tubes:

Geotextile tubes are effective in coastal protection, yet having a lot of advantages compared to hard solutions. Installation of geotextile tubes enables the nourishment of the beach with minimal time because only simple equipment and procedures are involved. Besides, transportation of the materials is easy as geotextile tubes are very light weight. The geotextile tubes are very flexible structures as they can be removed any time when no longer needed. Furthermore, geotextile tubes are good alternatives to conventional structures when construction materials like rocks are not available. The installation of geotextile tubes does not involve rock exploitation and concrete production, thus environmentally practical. Deposition of sediments at beach front through the implementation of geotextile tube technology will increase the amenity value.



Laying of TechTube Geotextile Tubes in progress



During Construction Photographs



During Construction Photographs



After Construction photographs

Present Status of the Project:

The project completed successfully in June 2022, and performing to the intended purpose, to the satisfaction of client and contractor.

For further details kindly contact :

TechFab India Industries Ltd.

711/712, Embassy Centre, Nariman Point, Mumbai – 400021

Tel: + 91– 22 - 2287 6224 / 6225 Fax: + 91– 22 - 2287 6218

E: info@techfabindia.com

W: www.techfabindia.com

CASE HISTORY

Rev:00, Date : 12.01.2021

PROTECTION & RECLAMATION WORK USING GEOTEXTILE TUBE (TECH TUBE) AT KATTUPALLI, TAMILNADU

KATTUPALLI, TAMIL NADU, INDIA



Coastal Protection

Main Contractor:	Products used & Quantity supplied:
ITD CEMENTATION INDIA LTD.	HIGH PERFORMANCE GEOTEXTILE TUBE (TECHTUBE 03m & 01m DIA & 20m LONG) - 217 NOS
Manufacturer & Supplier:	Year of construction:
TECHFAB (INDIA) INDUSTRIES LTD.	2020

Brief Project Information:

Kattupalli is located north of Ennore Port, about 40 km from Chennai, a major manufacturing and services hub of India. One of the facilities in the eastern coast of India, they have a captive jetty protected by breakwaters. Client wanted to Protect the shoreline from erosion as well as reclaim the land which was eroded over the period of time.

Problem:

M/s. ITD Cementation had approached us to design an economical solution for the protection of 620 m long stretch of proposed reclamation work. The initial proposal of construction of bund using rock armour was expensive & time consuming. If the reclamation work were to be undertaken in the open sea by the construction of a bund to protect the fill material being washed away, then this would have consequently damaged the ecological balance of the coastline.

It was confirmed from the soil investigation report that there would be a possibility for the development of pore water pressure and differential settlement due to very fine silty/sandy soil with clayey pockets. There were possibilities for failure due to differential settlement in case of construction of gravity structure (Rock Armor).

Solution:

After a site visit with the client, many parameters including the bed profile & wave pattern of the region was examined & understood. The requirement of the project was to raise the beach level to a height of + 6m from (-) 1m bed level. The tidal range that pertains to this region was +1.5m above (MSL) 7 (-) 1m below (MSL) as low tide, which is not very significant to affect the stability of the Geotextile tube.

We proposed using TechFab Geotextile tubes (TechTube), which were made of engineered high strength woven fabric, have had been thought of as an effective solution to the problem due to its capability of controlling the shore erosion caused by strong wave action on the one hand and facilitating the natural deposition of the sand layer behind them in longer-term.

The Geotextile tubes are sustainable since being manufactured from high-quality Virgin Polypropylene material can offer the function of containment, filter, and reinforce soil. The permeability of the soil fill and geotextile has a significant influence on the tube structure. The geotextile for tube manufacturing has been selected based on the performance requirement parameters like strength; filter (AoS); type of infill soil material; seam strength & durability parameters, etc.

Advantages of using Geotextile Tubes over rock structure

- The force of waves is reduced as it hits the sand-filled Geotextile tubes. Conversely, the rock structure was unable to suppress higher energy scouring the toe.
- Monolithic, Versatile and Flexible in nature.
- Even though there may be a differential settlement, the geotextile tube will adjust with the soil bed profile because of the flexibility and porous nature.
- Ease in the Installation, hence the time consumed is less. It is much faster than the rock structure works.
- The system posed characteristics of sustainability and Eco-Friendliness.
- Economical a compared to rock structure
- Beach formation.

The Geotextile tube embankment as shown in the drawing has been analyzed for internal & external factors affecting the stability of the geotextile tube structure. The toe of the main structure of 3+2+1 is provided with Toe tube to ensure protection from scour. Since Geotextile tube embankment will remain in exposed condition (as no armour layer would be given) the durability of the structure has further been improved by manufacturing tube in black colour (carbon black) & an additional sacrificial layer of Geotextile covering 60% of the exposed portion of the tube.

The schematic diagram of the proposed solution is shown here.

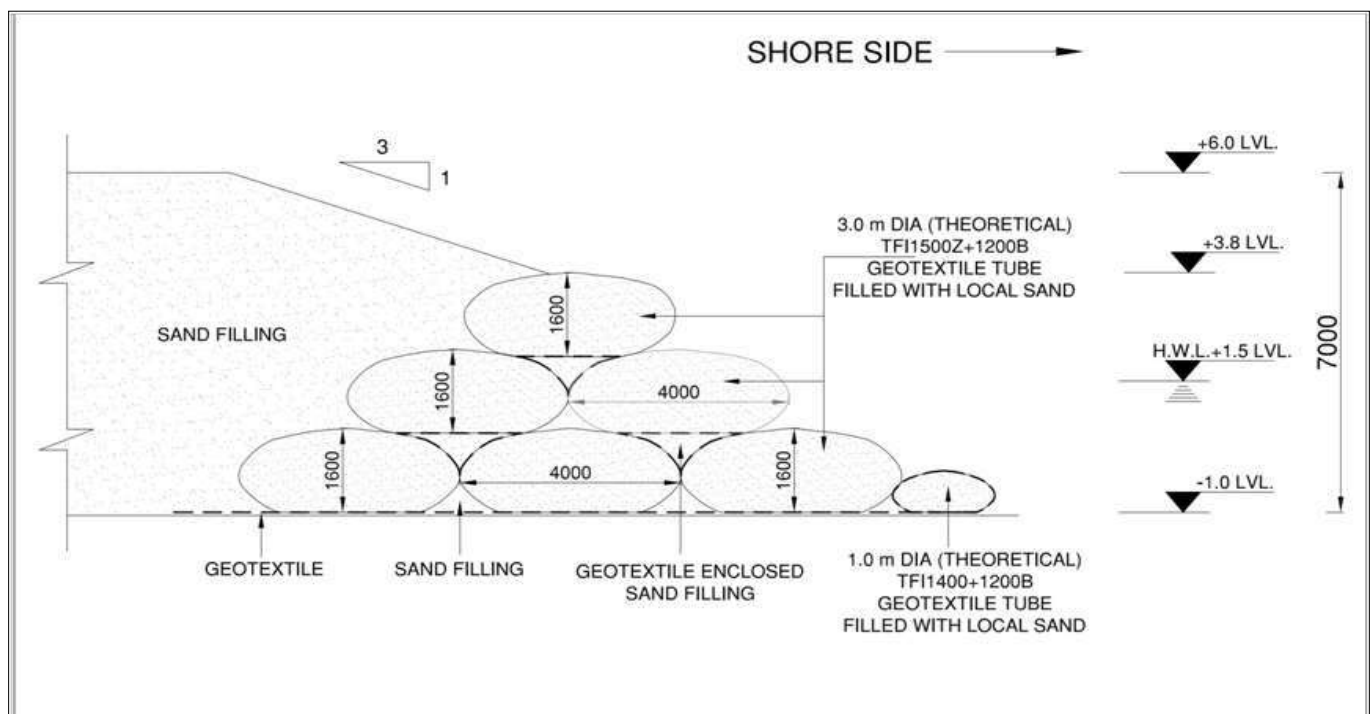

Schematic diagram of the proposed solution

Installation Method:

Before the start of Geotextile tube bund construction, the alignment was fixed with respect to shoreline & reclamation profile. A small tug-boat was used to fix alignment by fixing the Bamboo stick & floats in the sea. A temporary bund was created near the shoreline to store the entire quantity of dredged material. The necessary arrangement of pipe & 4-5 suction/sand pumps (min 10 Hp) mounted on pontoon had been installed to facilitate the filling operation of geotextile tube. Sand would be dredged from the area adjacent to the geotextile tubes at a distance of about 50 meters in the water. Owing to restriction in pumping distance of the sand pumps the piping length of the sand pump maintained at about 50 meters to avoid the drop in pressure. Approximately 32000 cubic meters of sand would be required to fill 186 numbers of geo tubes and 31 numbers of toe tubes.

Initially, the empty anchor's tube (toe tube) had been aligned on a relatively levelled bed prepared with pontoon mounted excavator & set finally by the external loops provided at the periphery of the Geotextile tube using a bamboo stick. The Non-woven Geotextile was placed on the prepared bed with suitable anchoring. Each tube has been provided with a filling port every 5m c/c. The Sand /water mixture has been pumped inside the geotextile toe tube port by adjusting the pressure (reducer) and length of the pipe for efficient filling of the tube. The filling of the Geotextile tube has been done sequentially & checked for any concentration or bye-pass of fines through the Geotextile tube, the partially filled Geotextile tube was allowed to settle down the fines by stopping the pumping for few hours. The pressure & filling time has been monitored throughout the complete filling of the tube. This procedure would be continued till the tubes were full with sand. The filling quality has been monitored for correct shape; Seam intactness, etc., then filling port would be closed down once the toe tube is filled with sand, the next toe tube will be placed and the reducer will be connected to the toe tube inlets and dredging shall be continued in a similar way till the entire 620m is covered.



Geotextile Tube filling is in progress



Filled first layer of Geotextile Tube



Aligning of 3rd Geotextile Tube in base layer is in progress



After complete laying Geotextile Tube in base layer and in middle layer (3+2)

The main Geotextile tube structure of embankment having arrangement 3+2+1m having each tube theoretical diameter of 3m dia. & 20 m long has been filled up with similar procedure by placing one tube at a time adjacent to already filled tube, the pumping operation was monitored & completed sequentially for Bottom layer with the seaside tube for all project stretch followed by middle and beachside geotextile tube; First layer & Top layer. No need to worry about the stability single layer of geotextile tube laid on the seaside as after complete filling, Geotextile tube would weigh after filling more than 150T. Due to heavyweight, a single Geotextile tube has no chance of any type of displacement in wave run-up and run-down condition.

Reclamation: The quantity accumulated in the temporary bund will be pushed in the newly formed area behind the Geotextile tube embankment structure with the help of dozers and excavators. The dried dredged soil will be levelled using an excavator/dozer by maintaining a slope of 1:3.

Conclusion: .The client appreciated technical support provided by TechFab not only in the design of protection bund but also during the installation of geotextile tubes till the completion of the project. The client was very happy with the quality of material and the timely supply of material provided by TechFab India.

This system has been successfully installed in this project. The geotextile tubes that have been proven as an effective alternative to conventional methods for this project and helped in shore protection, erosion control, and reclamation.

For further details kindly contact :

TechFab India Industries Ltd.

711/712, Embassy Centre, Nariman Point, Mumbai – 400021

Tel: + 91 - 22 - 2287 6224 / 6225 Fax: + 91 - 22 - 2287 6218

E: info@techfabindia.com

W: www.techfabindia.com

CASE HISTORY

Rev:01, Date : 22.05.2020

TECHFAB TECHTUBES FOR PROTECTION OF SHORELINE AND RESTORATION OF ERODED BEACH AT DAHANU IN MAHARASHTRA

DAHANU, MAHARASHTRA, INDIA



Coastal Protection

Client:	Products used:
MAHARASHTRA COASTAL DEPARTMENT	TECHTUBE TT10, 20m IN LENGTH
Main contractor:	Quantity supplied:
GOHEL & COMPANY	
Manufacturer & Supplier:	Year of construction:
TECHFAB (INDIA) INDUSTRIES LTD.	2011

Problem:

Dahanu is located on the western coast of India, facing Arabian Sea on the border of Maharashtra and Gujrat. The 1500m long beach is continuously eroding due to abrasive action of the sea waves. The increasing erosion of the beach has also endangered the adjoining structures and habitation near this location.

Solution:

The conventional methods for restoration of the beach and erosion control have been tried and found ineffective, the TECH-tubes made of engineered high strength woven fabric, have been thought of as an effective solution to the problem due to their capability of controlling the shore erosion caused by strong wave action on the one hand and facilitating the natural deposition of sand layer behind them in longer term. The geotextile tubes that have been proven worldwide as an effective alternative to conventional methods of shore protection, erosion control, and reclamation was proposed as a solution to the problem here. These systems have been successfully installed in various parts of the world for the construction of different type of marine and coastal structures. The schematic diagram of the proposed solution is shown here. The system has three components - a) Main tube (3.0m theoretical dia.) b) Anchor tube (1.0m theoretical dia.) and. c) Scour Apron made of high strength woven geotextile to prevent scouring of the base. The above system performs as erosion control mechanism for protection of shoreline and deposition of natural sand behind it. On the present project site the problem was that of continuous erosion of shoreline due to wave action.

To solve the problem a Groyne was proposed made of 3.0m theoretical diameter Tech-tube and an anchor tube of 1.0m theoretical diameter was installed in front of this as an anchor toe.



Installation of TechTube

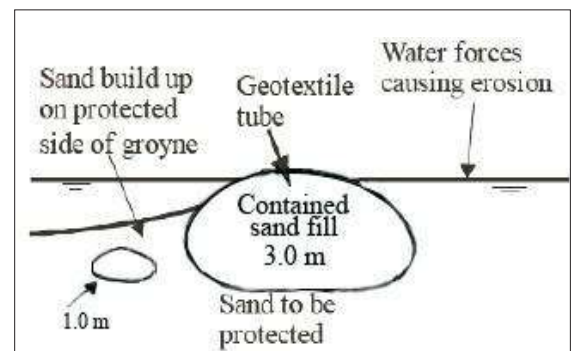

schematic diagram of the proposed solution

Installation:

Submersible slurry pumps were deployed to fill the Tech-tubes. A sand slurry mix of 70% water and 30% sand was pumped through 10 BHP pumps. This mix was pumped from the excavated pits made specifically to pump the sand slurry. The slurry was pumped into the Tech-tubes through the inlet ports provided on top of the tubes. The pumping operation was conducted in stages and planned according to the tides. After each filling operation the Tech-tubes are left for expulsion of water from fabric and consolidation of sand.



During Installation of TechTube



TechTube At Dahanu Beach

Conclusion:

The Tech-tubes have been installed on part of the eroded beach line. The flexible groyne made up of Tech-tubes is 1.6m high after consolidation. This coastal structure is found to fulfill the desired objective in successful manner.

For further details kindly contact :

TechFab India Industries Ltd.

711/712, Embassy Centre, Nariman Point, Mumbai – 400021

Tel: + 91– 22 - 2287 6224 / 6225 Fax: + 91– 22 - 2287 6218

E: info@techfabindia.com

W: www.techfabindia.com

CASE HISTORY

Rev:01, Date : 22.05.2020

**RECLAMATION & NOURISHMENT FOR DEVBAGH BEACH, AT DEVBAGH,
MALVAN, SINDHUDURG**
SINDHUDURG, MAHARASHTRA, INDIA



Coastal Protection

Client:	Products used:
PWD HARBOUR ENGINEER - SINDHUDURG, KUDAL	TECHTUBES
Main contractor:	Quantity supplied:
	44 NOS.
Manufacturer & Supplier:	Year of construction:
TECHFAB (INDIA) INDUSTRIES LTD.	MARCH 2013

Project description:

Devbagh is a small fishing village which sits on a thin strip of land with the Karli River backwaters on one side and the Arabian Sea on the other. Devbagh Beach is adjacent to Tarkarli Beach and ends at Devbagh Sangam. It is easily accessed via the Malvan-Tarkarli road. Devbagh beach is less crowded during the high tourist season and attracts tourists looking for peace and relaxation.

A point marks as the confluence of the Karli River flowing into the Arabian Sea, is the southernmost tip of the malvan taluka. An interesting geographical site, it is far more enchanting to see it atop the bridge built to cross over the river into Vengrula.



Overview of Devbagh beach

Solution:

Groynes are invented to slow down long shore waft and build up the beach. They are constructed at right angles to the shore with spacing about 50 - 100 meters apart so that they efficiently absorb the energy of the waves. Earlier days, they were typically made of tropical hardwoods or concrete. They are used to prevent coastal erosion by restricting the sediments, sand and debris from getting into contact with the shoreline. TechTubes are advanced and effective usages as Groynes for beach nourishment.



Typical Groynes

Salient features for the TechTube : Devbagh beach

Diameter of TechTube: 3.00 Meter

Length of TechTube: 20.00 Meter

Fill Port Diameter: 350.00 Millimeter

Fill Port Height: 500.00 Millimeter

Inlet Ports: 4.00 Nos.

Anchoring Loops: Every 3.00 Meter

Total Nos of TechTube: 44 Nos.

Total Length of TechTube: 880.00 Meter

TechTubes:

TechTubes are geotextile containment structures that have been used to encapsulate soil to enable their use as flexible, erosion resistant mass-gravity structures in hydraulic and marine applications. TechTubes are tubular containers that are formed on land or in water. TechTubes are laid out and filled onsite to their required geometrical form.



TechTubes At Devbagh Beach

Filling of TechTubes:

TechTubes are filled by hydraulically pumping fill into the tube. Hydraulic fill is pumped into the tube through filling ports (4 Nos.) located at specific intervals along the top of the geotextile tube. During filling, the geotextile tube, allows the excess water to pass through the geotextile while the retained fill attains a compacted, stable mass within the tube.

TechTube Material: (TFI-TT)

The Geotextile used to make the TechTube is engineered to have

- Tensile strength and stiffness to resist the mechanical stresses applied during filling and throughout the life of the structure
- Hydraulic properties to retain the sand fill and prevent erosion under a variety of hydraulic conditions
- Durability to remain intact over the design life of the units.

Fill Material:

Generally locally available sand is used as the fill material. The use of sand provides advantages such as attaining good density by hydraulic means, good internal shear strength and no consolidation affecting the filled shape of the TechTube. Once filled, the TechTube behaves as a mass-gravity unit. For Devbagh beach dredged material (Sandy soil) is used for filling TechTube.

Execution:

Construction for TechTube has been carried out with 3.0 meter diameter and 20.0 meter length of each tube. Techtube made from TFI-TT, being filled with the dredged material through filling ports, simultaneously to prevent higher pressure at each port. Anchoring loops are provided at every 3.0 meter. The construction for TechTube is designed as Groyne to prevent erosion and future beach nourishment.



TechTubes At Devbagh Beach

Conclusion:

The project was successfully completed in March 2013.

For further details kindly contact :

TechFab India Industries Ltd.

711/712, Embassy Centre, Nariman Point, Mumbai – 400021

Tel: + 91– 22 - 2287 6224 / 6225 Fax: + 91– 22 - 2287 6218

E: info@techfabindia.com

W: www.techfabindia.com

REHABILITATION OF SEA WALL AT MUKKACHERY, MANGALORE
MANGALORE, KARNATAKA, INDIA

Coastal Protection

Client:	Products used:
	TECHFAB NONWOVEN GEOTEXTILE BAG (SIZE - 1X1X0.3M)
Main contractor:	Quantity supplied:
	6985 NOS.
Manufacturer & Supplier:	Year of construction:
TECHFAB (INDIA) INDUSTRIES LTD.	2019 - 2020

Project description:

The coastal belt in Karnataka has been witnessing wind and high tides due to cyclonic depression, due to these many houses are facing threat due to rough sea waves.

Sea walls constructed at Mukkachery have been breached and several houses on the coast close to the sea were in danger. The district administration decided to take rehabilitation work of existing breached portion of sea wall by using tetra pods and sand filled geotextile bags, which will reduce the further erosion of the beach and provide indirect protection to the neighboring property which was damaging due to heavy wave action.



Project challenges:

Main challenge was timeline to install geotextile bags as wave action was deflected off the wall and concentrated on the sides and it was quickly eroding the shore line as well as damaging the neighbouring properties, so authority has suggested completing the work as early as possible in this difficult situation.

Execution on Site:

- The geotextile bags were filled with existing beach sand.
- The geotextile bags were filled to dry weight as per the specifications and design drawings
- Proper filling arrangement was made to fill the Geotextile Bags to ensure the complete filling of Bags.
- To ensure the qualities of filling random samples were taken from the Filled bags and their weight were checked. Then filled bags were stitched by using hand held machine.
- The site / beach was leveled before installing the Geotextile bags the installation of Geotextile bags was carried out by using excavator.
- As per design and drawing, 1m thick layer of rocks weighing 200 to 300kg is dumped using excavator, followed by laying of 3T tetra pods.



Dumping of Geotextile bags in progress



Laying of Geotextile bags in progress

Conclusion:

Project was executed in 2019 - 2020. Client was happy with quality of Geotextile bags and completion of the product supply on time. Project is still under observation and will be observed through Defects Liability Period of

For further details kindly contact :

TechFab India Industries Ltd.

711/712, Embassy Centre, Nariman Point, Mumbai – 400021
Tel: + 91– 22 - 2287 6224 / 6225 Fax: + 91– 22 - 2287 6218
E: info@techfabindia.com
W: www.techfabindia.com

CASE HISTORY

Rev:00, Date : 18.09.2020

SHORE PROTECTION WORK NEAR DANKA TEMPLE FROM DARIYA CHOWK TO EARTH BANK WITH TECHFAB METAL GABION MATTRESS AND TECHCELL GEOCELL AT KHAMBHAT, GUJARAT
NEAR ANAND, GUJARAT, INDIA



Coastal Protection

Client:	Products used & Quantity Supplied:
PUBLIC WORKS DEPARTMENT, GUJARAT	• TECHFAB METAL GABION MATTRESS 6X8, ZN+PVC COATED (05X02X0.3) - 465 NOS 4650 SQ.MT
Main contractor:	• TECHCELL GEOCELL TCI 445*100 - 3016 SQM
H C PARMAR	• NONWOVEN GEOTEXTILE PR 20 - 3200 SQM
Manufacturer & Supplier:	Year of construction:
TECHFAB (INDIA) INDUSTRIES LTD.	JUNE 2020

Project brief & Challenges:

Khambhat, also known as Khambhat and Cambay, is a town and the surrounding urban agglomeration in Khambhat Taluka, Anand district in the Indian state of Gujarat. It was once an important trading centre, but its harbour gradually silted up, and the maritime trade moved elsewhere.

Scientists have found that these mudflats are experiencing severe erosion which is threatening nearby habitat. The researchers found that a total of about 28.66 Sq.km area of high tidal mudflats has got eroded within a span of just three and a half years - from March 2014 to September 2017. The erosion rate was observed to be very high at 3.5 to 4 km per year, according to results of the study recently published in journal Current Science.

The erosion is higher in winter and pre-monsoon seasons than during the summer monsoon. It appears to be because of high input of fresh water during the summer monsoon, which prevents strengthening of current velocity during high tide. Although high tidal mudflats are rarely flooded even under high tide conditions, extensively high erosion has been observed along the 20 km long stretch and about 3 km inside. The high rate of erosion has changed the shoreline.

The Gulf of Khambhat is a hotspot for major development activities, authority wanted a solution so that the mudflats are saved before they are destroyed totally. The site gets inundated during high tides and the department is looking for a solution which can effectively function as a barrier for the offshore and can prevent further inundation.

Main challenge was to work on site only few hours available in between low tide and high tide, working hours depends on tide timings. Otherwise site is clear and no issue to work.



Site condition before construction

Solution:

After considering all data available, the solution was proposed i.e. construction of levee. A levee is simply a man-made embankment built to keep a river from overflowing its banks or to prevent ocean waves from washing into undesired areas. Levees of 2.5m height was proposed to prevent offshore against inundation.

- The Levee system with earthen core which is covered with geomembrane to avoid water percolation in the earthen core. A layer of nonwoven geotextile is provided as a separation/filteration layer.
- The slope of embankment towards sea side is more prone to erosion or scour due to wave action, where it was suggested to use Gabion Mattresses on top and beneath mattresses Geomembrane is suggested as Impermeable liner .
- A launching apron was provided towards sea facing for mitigating formation of scour hole near to the toe and thereby preventing the levee against toe erosion.
- Beach side slope which is not much exposed and faces mild surface erosion so it was suggested to use geocell (Techcell TCI – 445x100) for preventing surface erosion due to runoff and enabling a turf reinforcement cover by improving vegetation.

Proposed solution shown in the Figure -1

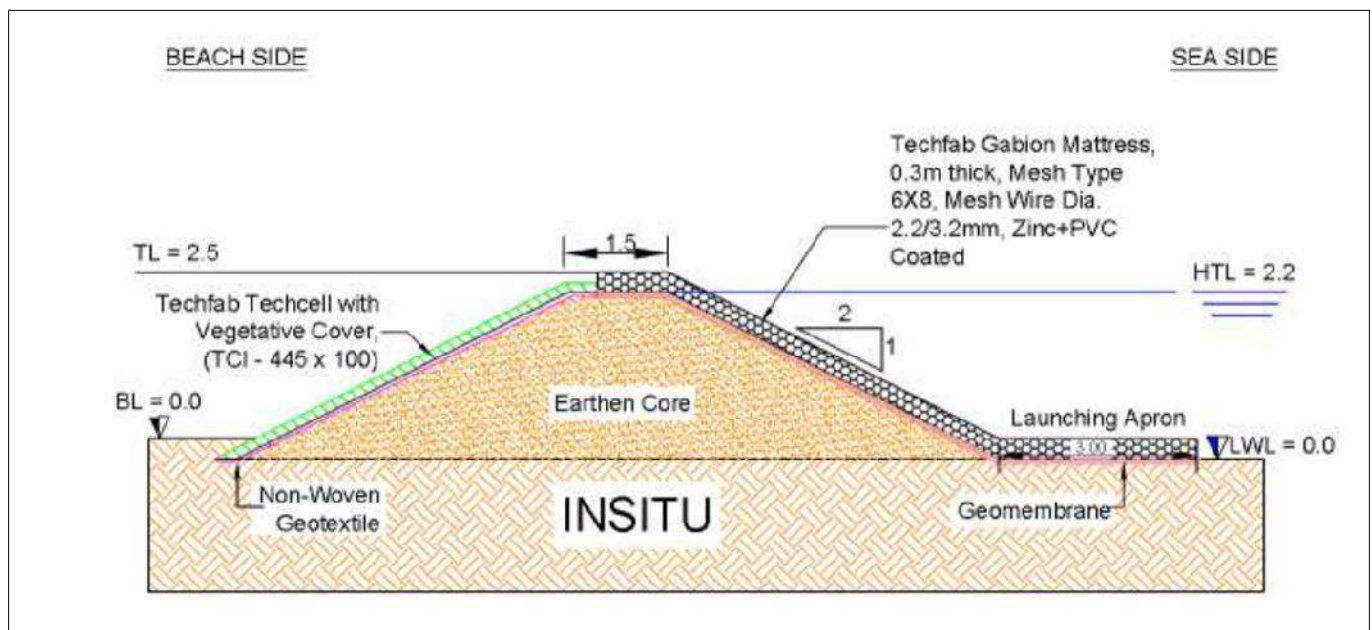

Figure 1 Showing Typical Schematic Section of Proposed levee

Why Techcell Geocell ?

- A light weight yet strong 3 dimensional honeycomb like confinement system.
- The 3D confinement prevents movement and shearing of soil infill, soil erosion along steep slope.
- Techcell is perforated to allow water to pass thus dissipating water pressure and enhanced drainage.
- Installation is very easy and fast in all weather conditions.
- Techcell landscaping gives aesthetically pleasant view.

Why TechFab Metal Gabion Mattresses ?

- Metal Gabion Mattresses structures are heavy monolithic flexible lining able to protect from erosion.
- For any given hydraulic condition the average size of stone fill needed for Gabion mattresses is half that required for a rip rap revetment.
- The condition of 'initial movement' for rip rap is a limit condition beyond which the lining is progressively destroyed as the separate elements are removed by the flow. However, in Gabion mattress after the 'initial movement' the containment offered by the mesh remains. A new situation of equilibrium with a deformed Gabion mattress is obtained, allowing it to withstand more severe conditions without compromising the resistance and without further deformation.

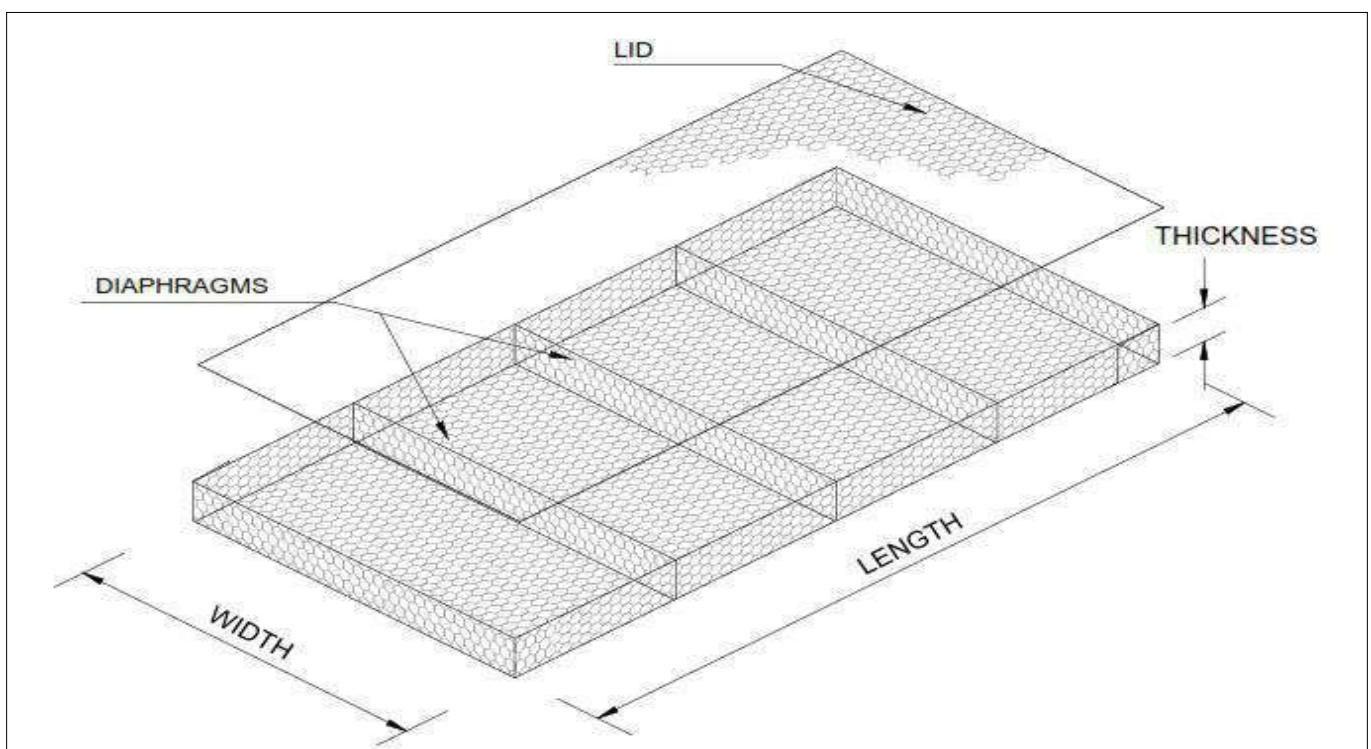

Gabion Mattress

Why TechGeo Nonwoven geotextile ?

- When the infill and sub grade are different, or if the sub grade is very soft or wet. A layer geotextile can provide a useful separation function by keeping the infill from migrating out from under the geocell.
- The Geotextile is used to prevent soil beneath it from erosion due to water flowing over.
- TechGeo act as separation layer, filtration, and drainage layer to some extent.

Execution at Site For embankment

- Prepare embankment with recommended type of soil with 2H:1V slope on either side as per given approved drawings.
- Remove the debris, kankars, unacceptable soil or garbage from the embankment slope.
- Both slopes are prepared and well compacted using plate compaction then a layer geomembrane is laid as specified in the drawing.
- As per drawing, installed the non-woven geotextile on the prepared well compacted slope, overlap should be provided as mentioned in the drawings or installation guidelines.
- Installation of Gabion mattresses towards the sea side done first to secure the Embankment.



Prepared Embankment with low tide

Execution at site for slope on the sea side

- The ground surface over which the gabion mattresses are to be laid should be inspected for any irregularities or weak pockets. It is recommended that the surface over which the gabion mattresses and Geomembrane is placed should be even and firm.
- In case any irregularities or weak pockets are observed, they must be rectified by removing the weak soil and replacing by good soil and well compacted.
- For the purpose of easy transportation, the Gabion mattresses are bundled and packed in a flat folded manner. Each mattress was carefully opened out, laid flat and straightened out so that all the kinks and creases are removed. The sides and the diaphragm are then lifted vertical and laced together to form a mattress like structure. (Refer Fig.1).



On the sea side slope - Gabion Mattress laying in progress

- Gabion mattresses were laid on the slope and then laced together. The adjoining Gabion Mattresses were firmly wired together to give a continuous joint along all edges. The lacing should be continuous and not in individual loops. It is easy and recommended to lace the Gabion Mattresses when they were empty to ensure correct lacing.
- All adjoining empty gabion mattresses were laced along the perimeter of contact surfaces to obtain a monolithic structure.
- Before filling, the gabion mattresses were accurately placed in required position, tensioned and straightened to remove all kinks. The gabion mattress was hand packed. The stones were tightly packed so as to achieve maximum density and minimum voids.
- By using well graded stone fill and by hand packing of the stone fill. Also care was taken not to damage the mesh particularly due to sharp stones. The stones used for Gabion mattresses filling were as per guideline shared by TechFab India.
- The gabion mattresses were over filled by about 25 to 50mm before closing to allow for settlement. The lids were then stretched over the stone fill and laced down. The corners of the lids were secured first. Removing or redistributing of some stones on the top was required while closing of the lids. The lids were then laced down securely. Lace selvedge wire to selvedge wire using the same procedure as mentioned in the installation manual.

Execution at site for slope on the beach side

- Position the Geocell section along the slope direction.
- Install J shaped anchors on the top with proper alignment to hold Techcell section in place on the slope.



Geomembrane & Nonwoven geotextile layer is laid and Gabion Mattress installation in progress



Techcell Geocell installation in progress

- Expand down the Techcell section on the slope as per the expandable dimension suggested for each techcell section and then fix Techcell by using J shaped anchors.
- Adjacent Techcell section must be leveled with each other and tie with each other using cable string supplied with Geocell.
- Install J hooks at specified distance as per the drawing to fix the Techcells .
- When Techcell has been laid in place properly, Techcell should be filled with specified material.
- To prevent possible damage, limit drop height of infill to not more than 1m.
- Infill should be delivered either to top of slope or bottom of slope using a loader.
- When using vegetative soil fills, overfill section by 25 to 50 mm to allow for settling and compaction.
- For vegetative slope, locally available vegetative soil should be utilized as infill. Vegetation grows naturally or local seeds can be implanted to ensure the fast vegetation growth.



Sea side slope with Metal Gabion Mattress

For further details kindly contact :

TechFab India Industries Ltd.

711/712, Embassy Centre, Nariman Point, Mumbai – 400021

Tel: + 91- 22 - 2287 6224 / 6225 Fax: + 91- 22 - 2287 6218

E: info@techfabindia.com

W: www.techfabindia.com



At the Heart of Geosynthetic Activity

TECHFAB INDIA

At the Heart of Geosynthetic Activity

We, at TechFab India are committed to finding a solution for every single Geosynthetics, Hydraulics and Rockfall Protection & GeoHazard Mitigation need of our customers !



“ We offer the following products:

- Geogrids
- Woven & Non-woven Geotextiles
- Geocells
- Drainage Geocomposites
- Prefabricated Vertical Drains (PVD)
- Gabions
- Geotextile Bags & Tubes
- GeoMattress
- Rhomboidal Steel Cable Mesh Panels
- High Tensile Steel Wire Mesh
- Self Drilling Anchors

Download TechFab India Mobile App now !!



TechFab India Industries Ltd.
712, Embassy Centre,
Nariman Point, Mumbai - 400021
Tel: + 91- 22 - 2287 6224 / 6225
Email : info@techfabindia.com
Website : www.techfabindia.com







15 YEARS OF EXCELLENCE IN REINFORCED SOIL WALLS AND SLOPES

- TechGrid Geogrids and TechStrap Polymeric Strips are successfully used as reinforcements along with TechDrain Drainage Composite and TechGeo Nonwoven Geotextile, for Reinforced Soil Walls for Flyovers, Underpasses and ROBs in India & Abroad.
- TechFab India's qualified and experienced technical team is equipped with the latest design tools for excellent technical support.
- In house NABL and GAI-LAP certified, testing laboratory equipped with latest instruments.
- Largest manufacturer of Geosynthetics in India with ability to supply bulk quantities to project sites across India.
- TechFab India has developed DMS, Advanced Data Management System to support design document database for complex projects having multiple structures.
- More than 45 lacs sqm of Reinforced Soil Walls are completed.
- Exported our products to 35 countries.

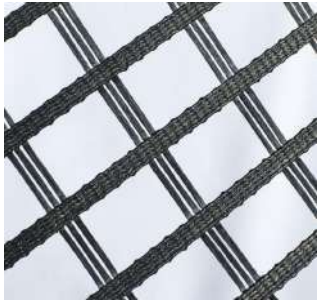
 TechGrid knitted & polymeric coated Polyester Geogrids



- High tensile strength with low strain
- Resistance to chemical and biological degradation, UV and Installation damage
- Used as a reinforcement for Reinforced Soil Walls and slopes
- Range: 40 kN/m to 400 kN/m
- Capability - 60 lakhs square meters of wall face area per annum

 TechStrap Polymeric Geostrips



- High tenacity polyester filament yarns are used
- High tensile strength and modulus, low creep
- Used as a reinforcement for Reinforced Soil Walls and slopes
- Range: 30 kN to 100 kN
- Capability - 15 lakhs square meters of wall face area per annum

 TechDrain DRAINAGE COMPOSITE



- High water inflow enhances effective drainage system.
- Complete or partial replacement to conventional filter media.
- Used as drainage layer behind the wall
- Production Capacity - 90 lakhs square meters per annum

 **TECHGEO**
nonwoven geotextiles
Nonwoven Geotextile



- Made from Specially engineered UV stabilized 100% Polypropylene fiber
- More resistant to puncture
- Excellent filtration
- Used as a drainage layer behind the wall
- Range: 150 Gsm to 1200 Gsm
- Production Capacity - 120 lakhs square meters per annum



TECHFAB INDIA
At the heart of geosynthetic activity

TechFab India Industries Ltd.

Head office :

712, Embassy Centre, Nariman Point, Mumbai - 400 021, India.

• Tel : + 91-22-2287 6224 / 25 • Fax : + 91-22-2287 6218

• Email : info@techfabindia.com

• Website : www.techfabindia.com

Regional Sales Offices : • New Delhi • Hyderabad • Vadodara



15 YEARS OF EXCELLENCE IN REINFORCED SOIL WALLS

- TechGrid Geogrids and TechStrap Polymeric Strips are successfully used for Reinforced Soil Walls for Flyovers, ROBs and Underpasses in India & Abroad.
- Till date more than 45 lacs sqm of Reinforced Soil Walls are accomplished.
- TechFab India is equipped with qualified and experienced technical team with latest design software.



Our Products

TECHGEO

TechDrain
PVD

TechRhombus HRC
High Tensile Rope Net System

TECHGRID

TechStrap

TechDrain
DRAINAGE COMPOSITE

TechFab-Metal Gabion

TECHGRID
Base Geogrid

TECH TUBE

TechCell

Certified At:

Products Tested At:

AASHTO's
National Transportation
Product Evaluation
Program



BTRA, MUMBAI

TRL, USA

IRC, MADRAS

BTTL, UK

BICL, UK

IT, DELHI



Enhance Your Project by Incorporating
Quality Geosynthetics from
TechFab India Industries Ltd.
www.techfabindia.com

WHY MOST BRIDGES FAIL ?



Scour is the largest cause of highway bridge failures in India.

During flood, the formation of vortex and the associated flow around the pier results in increased shear stress and increase in the local sediment transport capacity of flow. This results in the formation of scour hole.



Don't worry ! This can be prevented with countermeasure design.

We have cost effective sustainable solution for you- TechFab Metal Gabion with TechGeo which assure bridge will stay as it ,no scour under floods to come for next 100 years .

World-class Geosynthetics Manufactured in India by Techfab India Industries Ltd.													
TFI Woven Geotextiles		TechGrid Geogrids	TGC Reinforced Nonwoven Composites	TechDrain PVDs	TechDrain Drainage Composite	TechGeo Mattress	TechMat Erosion Control Mat	TechGeo Nonwoven Geotextile TechPave	TechFab Metal Gabion Double twist wire mesh products	TECHTUBE & Geotextile Bags	TechGrid PP Biaxial Geogrids	TechStrap Polymeric Strip	TechFab Geocell
Polypropylene Multifilament	Polyester Multifilament												

TechFab In house laboratory is accredited With ISO/IEC - 17025: 2017 & GRI-GAILAP



TECHFAB INDIA

At the heart of geosynthetic activity

TechFab India Industries Ltd.

Head Office :

712, Embassy Center, Nariman Point, Mumbai - 400 021, India.

• Tel: + 91-22-2287 6224 / 25 • Fax : + 91-22-2287 6218

• Email : anant@techfabindia.com

• Website : www.techfabindia.com

Regional Sales Offices : • New Delhi • Hyderabad • Vadodara

Hydraulic Application with TFI



Exclusive

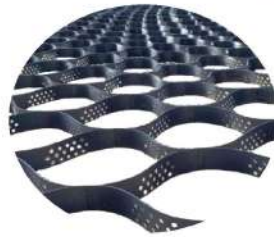

TechFab India Industries Limited
Where The World shops For Geosynthetics

River Bank Protection With Metal Gabion



TechFab India Industries Limited
Where The World shops For Geosynthetics



Want Greener ?

Go Green with our New Product Tech GeoMattress...



Tech Geomattress

The Tech GeoMattress system is a flexible revetment protection system. Tubular system is manufactured from two layers of geotextile, upper layer is green colored composite fabric having green cut fiber on top and bottom layer is high strength woven fabric.

Follow us on :  
www.techfabindia.com



TECHFAB INDIA

At the Heart of Geosynthetic Activity

River Embankment Protection with Tech Geomattress



Why Tech Geomattress ?

- *Highly efficient in erosion control in water channels*
- *Robust & flexible revetment, once filled with infill material*
- *Works efficiently as filter media*
- *Speedy & easy installation*
- *Promotes natural vegetation growth*
- *Provides an aesthetic green look to structure*
- *Sustainable & eco-friendly*
- *Economical, time efficient & easy to transport*

Note : All the images shown in this Advertisement are indicative only. The site is not owned to TechFab India. This is only for reference purpose.

711/712, Embassy Centre, Nariman Point, Mumbai - 400021, Tel: + 91- 22 - 2287 6224 / 6225 Fax: + 91- 22 - 2287 6218
E: info@techfabindia.com W: www.techfabindia.com

TechFab India's Highest Quality Products for Rockfall Protection & GeoHazard Mitigation

TechFab India is the manufacturer of TechRhombus High Tensile Rope Net System, the strongest rockfall net in India with tensile strength of more than 280 kN/m with wide range of selection according to your project needs. TechRhombus is a flexible system which can be used to protect railway lines and infrastructure passing through deep cutting and hill slopes.

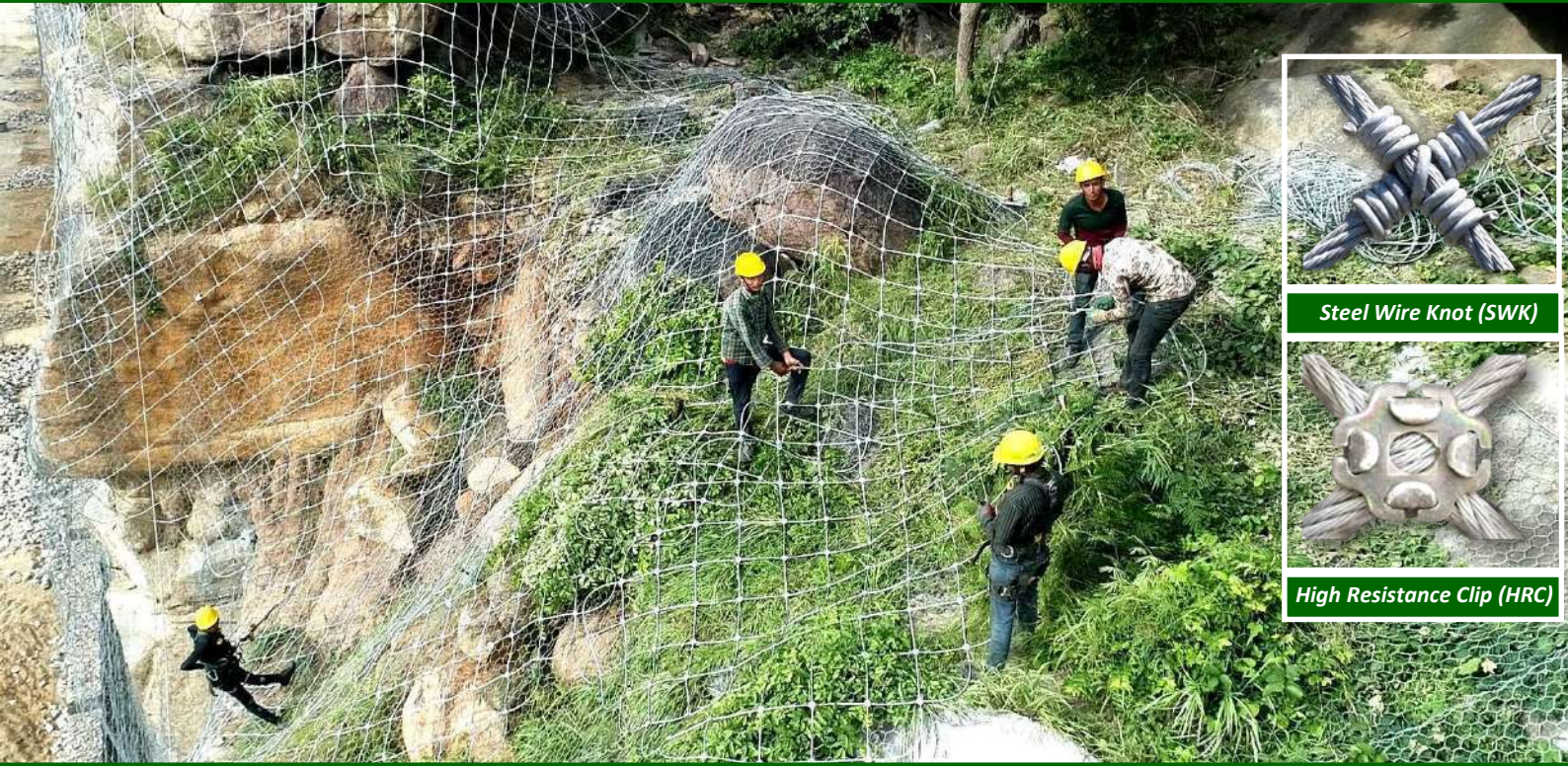

Steel Wire Knot (SWK)



High Resistance Clip (HRC)

TechFab India is also manufacturing state-of-the-art Self Drilling Anchors (SDA) in India along with its accessories for slope stabilization, stabilization of tunnel portals, micro piling etc.



TechAnchor



712, Embassy Centre, Nariman Point,
Mumbai - 400021

Tel: + 91- 22 - 2287 6224 / 6225

Email: info@techfabindia.com

Website: www.techfabindia.com

Download TechFab India Mobile App now !!

